

DM74LS365A Hex 3-STATE Buffers

General Description

This device contains six independent gates each of which performs a non-inverting buffer function. The outputs have the 3-STATE feature. When enabled, the outputs exhibit the low impedance characteristics of a standard LS output with additional drive capability to permit the driving of bus lines without external resistors. When disabled, both the output transistors are turned off presenting a high-impedance state to the bus line. Thus the output will act neither as a signifi-

cant load nor as a driver. To minimize the possibility that two outputs will attempt to take a common bus to opposite logic levels, the disable time is shorter than the enable time of the outputs.

Features

- Alternate Military/Aerospace device (54LS365A) is available. Contact a Fairchild Semiconductor Sales Office/Distributor for specifications.

Connection Diagram

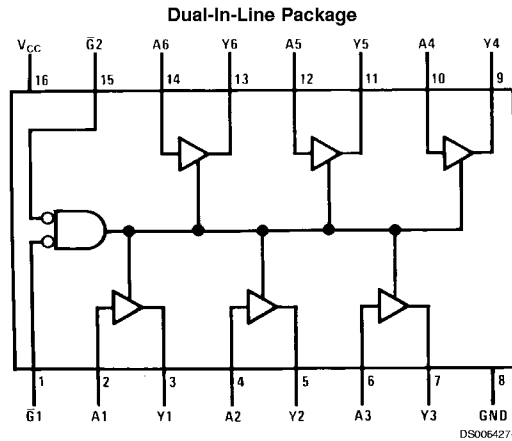

Order Number 54LS365ADMQB, 54LS365AFMQB, 54LS365ALMQB,
DM54LS365AJ, DM54LS365AW, DM74LS265AM or DM74LS365AN
See Package Number E20A, J16A, M16A, N16E or W16A

Function Table

$Y = A$

Input			Output
$\bar{G}1$	$\bar{G}2$	A	Y
H	X	X	Hi-Z
X	H	X	Hi-Z
L	L	H	H
L	L	L	L

H = High Logic Level
L = Low Logic Level
X = Either Low or High Logic Level
Hi-Z = 3-STATE (Outputs are disabled)

Absolute Maximum Ratings (Note 1)

Supply Voltage	7V	DM54LS and 54LS	-55°C to +125°C
Input Voltage	7V	DM74LS	0°C to +70°C
Operating Free Air Temperature Range		Storage Temperature Range	-65°C to +150°C

Recommended Operating Conditions

Symbol	Parameter	DM54LS365A			DM74LS365A			Units
		Min	Nom	Max	Min	Nom	Max	
V _{CC}	Supply Voltage	4.5	5	5.5	4.75	5	5.25	V
V _{IH}	High Level Input Voltage	2			2			V
V _{IL}	Low Level Input Voltage			0.7			0.8	V
I _{OH}	High Level Output Current			-1			-2.6	mA
I _{OL}	Low Level Output Current			12			24	mA
T _A	Free Air Operating Temperature	-55		125	0		70	°C

Note 1: The "Absolute Maximum Ratings" are those values beyond which the safety of the device cannot be guaranteed. The device should not be operated at these limits. The parametric values defined in the "Electrical Characteristics" table are not guaranteed at the absolute maximum ratings. The "Recommended Operating Conditions" table will define the conditions for actual device operation.

Electrical Characteristics

over recommended operating free air temperature range (unless otherwise noted)

Symbol	Parameter	Conditions	Min	Typ (Note 2)	Max	Units	
V _I	Input Clamp Voltage	V _{CC} = Min, I _I = -18 mA			-1.5	V	
V _{OH}	High Level Output Voltage	V _{CC} = Min, I _{OH} = Max V _{IL} = Max, V _{IH} = Min	2.4	3.4		V	
V _{OL}	Low Level Output Voltage	V _{CC} = Min, I _{OL} = Max	DM54	0.25	0.4	V	
		V _{IL} = Max, V _{IH} = Min	DM74	0.35	0.5		
		I _{OL} = 12 mA, V _{CC} = Min	DM74	0.25	0.4		
I _I	Input Current @ Max Input Voltage	V _{CC} = Max, V _I = 7V			0.1	mA	
I _{IH}	High Level Input Current	V _{CC} = Max, V _I = 2.7V			20	μA	
I _{IL}	Low Level Input Current	V _{CC} = Max, V _I = 0.5V (Note 5)	A Input			-20	mA
		V _{CC} = Max, V _I = 0.4V (Note 6)	A Input			-0.4	
		V _{CC} = Max, V _I = 0.4V	\bar{G} Input			-0.4	
I _{OZH}	Off-State Output Current with High Level Output Voltage Applied	V _{CC} = Max, V _O = 2.4V V _{IH} = Min, V _{IL} = Max			20	μA	
I _{OZL}	Off-State Output Current with Low Level Output Voltage Applied	V _{CC} = Max, V _O = 0.4V V _{IH} = Min, V _{IL} = Max			-20	μA	
I _{OS}	Short Circuit Output Current	V _{CC} = Max (Note 3)	DM54	-20		-100	mA
			DM74	-20		-100	
I _{CC}	Supply Current	V _{CC} = Max (Note 4)		14	24	mA	

Note 2: All typicals are at V_{CC} = 5V, T_A = 25°C.

Note 3: Not more than one output should be shorted at a time, and the duration should not exceed one second.

Note 4: I_{CC} is measured with the DATA inputs grounded and the OUTPUT CONTROLS at 4.5V.

Note 5: Both \bar{G} inputs are at 2V.

Note 6: Both \bar{G} inputs at 0.4V.

Switching Characteristics

at $V_{CC} = 5V$ and $T_A = 25^\circ C$

Symbol	Parameter	$R_L = 667\Omega$				Units
		$C_L = 50\text{ pF}$		$C_L = 150\text{ pF}$		
		Min	Max	Min	Max	
t_{PLH}	Propagation Delay Time Low to High Level Output		16		25	ns
t_{PHL}	Propagation Delay Time High to Low Level Output		16		25	ns
t_{PZH}	Output Enable Time to High Level Output		30		40	ns
t_{PZL}	Output Enable Time to Low Level Output		30		40	ns
t_{PHZ}	Output Disable Time from High Level Output (Note 7)		20			ns
t_{PLZ}	Output Disable Time from Low Level Output (Note 7)		20			ns

Note 7: $C_L = 5\text{ pF}$.

Physical Dimensions inches (millimeters) unless otherwise noted

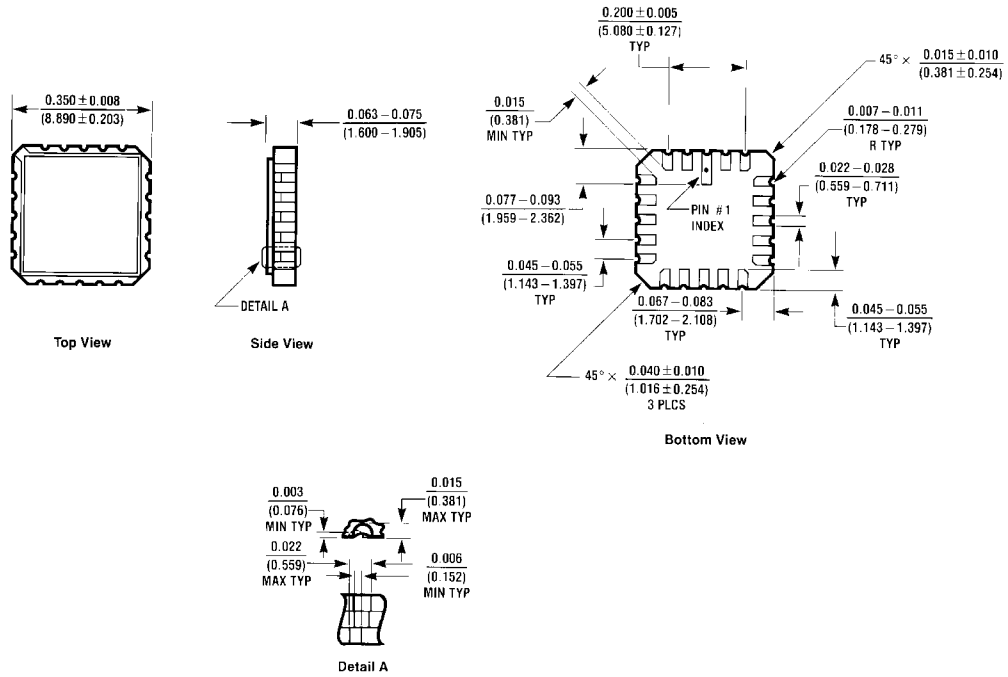

EDCA (REV D)

Ceramic Leadless Chip Carrier Package (E)
Order Number 54LS365ALMQB
Package Number E20A

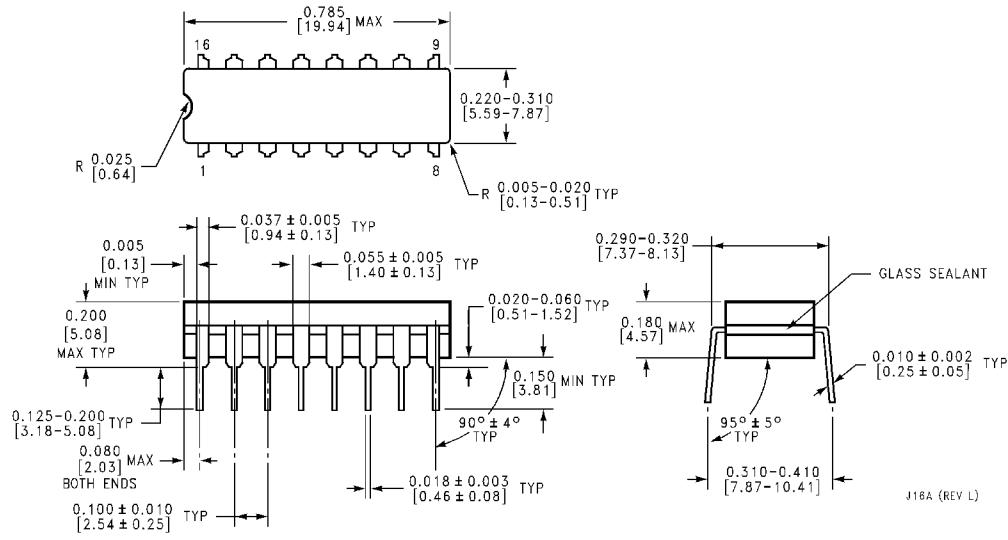

J16A (REV L)

16-Lead Ceramic Dual-In-Line Package (J)
Order Number 54LS365ADMQB or DM54LS365AJ
Package Number J16A

Physical Dimensions inches (millimeters) unless otherwise noted (Continued)

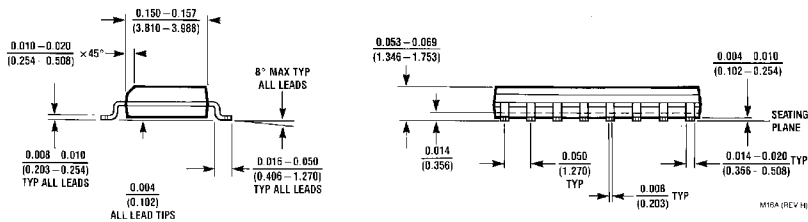
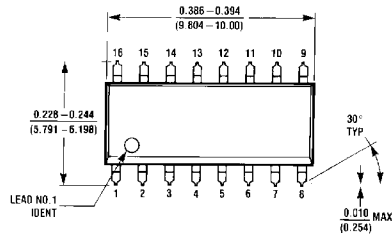

16-Lead Small Outline Molded Package (M)
Order Number DM74LS365AM
Package Number M16A

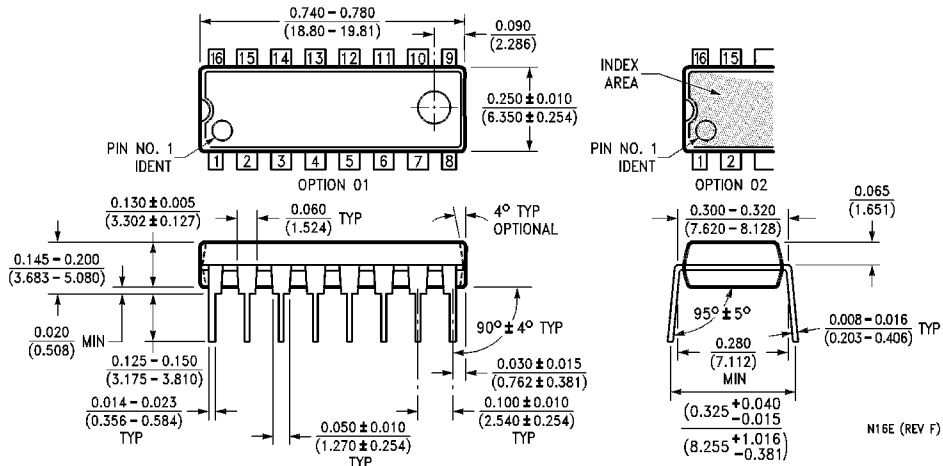

16-Lead Molded Dual-In-Line Package (N)
Order Number DM74LS365AN
Package Number N16E

DM74LS365A Hex 3-STATE Buffers

Physical Dimensions inches (millimeters) unless otherwise noted (Continued)

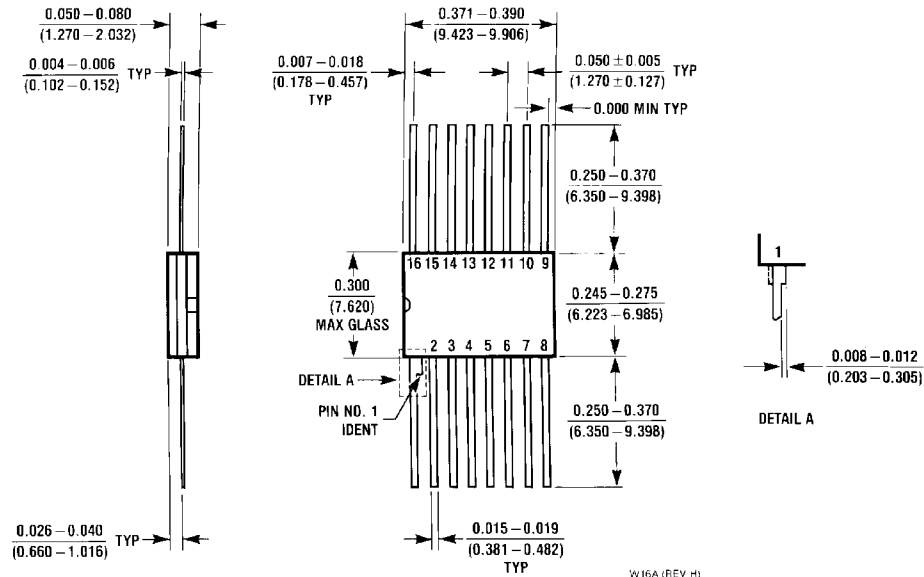

16-Lead Ceramic Flat Package (W)
Order Number 54LS365AFMQB or DM54LS365AW
Package Number W16A

LIFE SUPPORT POLICY

FAIRCHILD'S PRODUCTS ARE NOT AUTHORIZED FOR USE AS CRITICAL COMPONENTS IN LIFE SUPPORT DEVICES OR SYSTEMS WITHOUT THE EXPRESS WRITTEN APPROVAL OF THE PRESIDENT OF FAIRCHILD SEMICONDUCTOR CORPORATION. As used herein:

1. Life support devices or systems are devices or systems which, (a) are intended for surgical implant into the body, or (b) support or sustain life, and (c) whose failure to perform when properly used in accordance with instructions for use provided in the labeling, can be reasonably expected to result in a significant injury to the user.
2. A critical component in any component of a life support device or system whose failure to perform can be reasonably expected to cause the failure of the life support device or system, or to affect its safety or effectiveness.

Fairchild Semiconductor Corporation
 Americas
 Customer Response Center
 Tel: 1-888-522-5372

Fairchild Semiconductor Europe
 Fax: +49 (0) 1 80-530 85 86
 Email: europe.support@nsc.com
 Deutsch Tel: +49 (0) 8 141-35-0
 English Tel: +44 (0) 1 793-85-68-56
 Italy Tel: +39 (0) 2 57 5631

Fairchild Semiconductor Hong Kong Ltd.
 13th Floor, Straight Block,
 Ocean Centre, 5 Canton Rd.
 Tsimshatsui, Kowloon
 Hong Kong
 Tel: +852 2737-7200
 Fax: +852 2314-0061

National Semiconductor Japan Ltd.
 Tel: 81-3-5620-6175
 Fax: 81-3-5620-6179

www.fairchildsemi.com