

PART NUMBER	ENGINEERING NO.	LENGTH
1300250543	DND99A-M010	3' 3" +2.19 - 0 [ 1.0M +55.6 - 0 ]
1300250544	DND99A-M030	9' 10" +3.50 - 0 [ 3.0M +88.9 - 0 ]
1300250545	DND99A-M050	16' 5" +6.50 - 0 [ 5.0M +165.1 - 0 ]

- NOTES:
1. MATERIAL: SEE TABLE
  2. FINISHES: SEE TABLE
  3. CABLE ASSEMBLIES ARE BAGGED SEPARATELY IN POLY BAGS WITH BARCODE LABEL ATTACHED TO OUTSIDE OF BAG
  4. WRAP LABEL IS MARKED WITH P/N, DATE CODE VOLTAGE & AMPERAGE
  5. MATES WITH: MINI CHANGE, A-SIZE 5 POLE RECEPTACLE
  6. ELECTRICAL SPECIFICATIONS:  
VOLTAGE RATING: 300V  
CURRENT RATING: 4 AMPS
  7. ASSEMBLY IS RoHS COMPLIANT

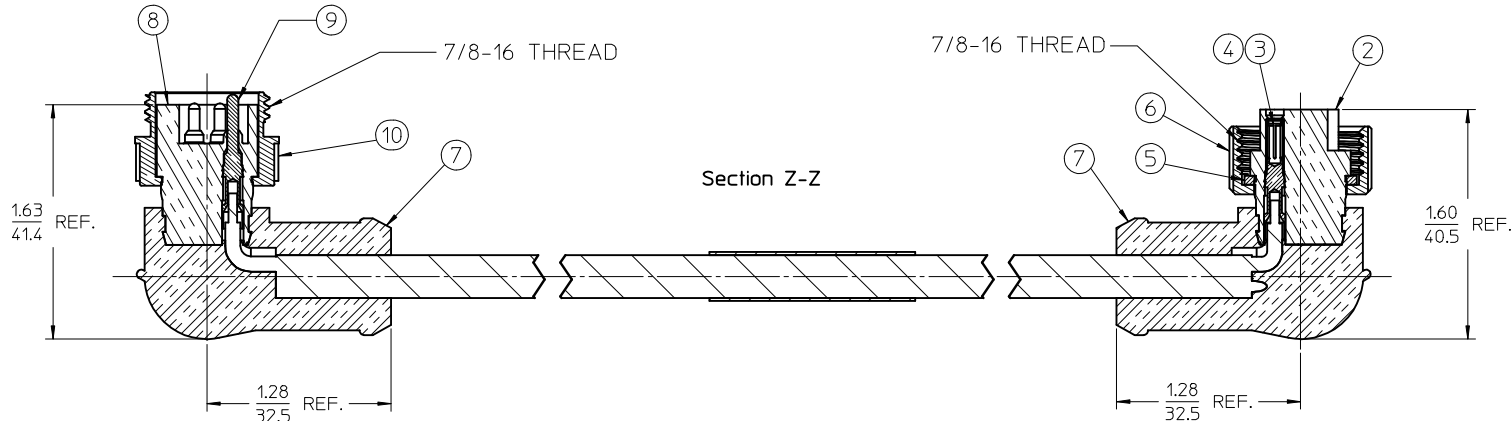
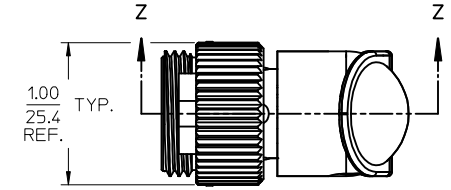
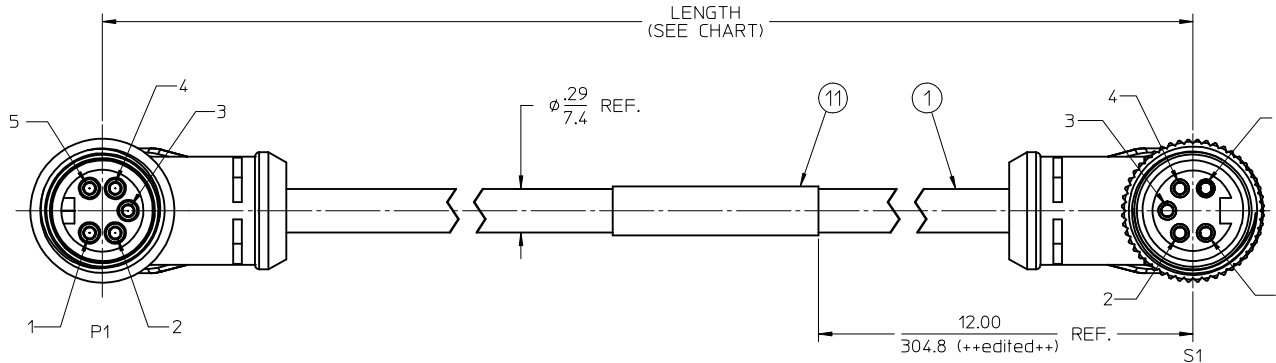
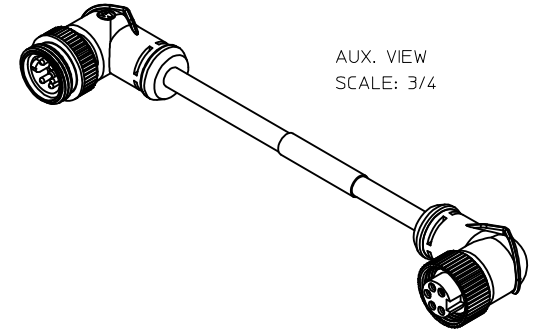

P1		S2
1	DRAIN	1
2	RED +V	2
3	BLACK -V	3
4	WHITE CAN H	4
5	BLUE CAN L	5

WIRING DIAGRAM

ITEM	QTY.	DESCRIPTION	MATERIAL	FINISH
11	1	LABEL	PLASTIC FILM	BLACK/YELLOW
10	1	COUPLING NUT, MALE	ZINC DIE CAST	BLACK
9	5	CONTACT PIN, 22 AWG	BRASS	GOLD PLATED
8	1	INSERT, MALE, 5 POLE	PVC	GRAY
7	2	OVERMOLD, 90 DEG	PVC	GRAY
6	1	COUPLING NUT, FEMALE	ZINC DIE CAST	BLACK
5	1	FRICTION RING	NYLON	WHITE
4	5	SOCKET SLEEVE	ST. STEEL	
3	5	CONTACT SOCKET, 22 AWG	BRASS	GOLD PLATED
2	1	INSERT, FEMALE, 5 POLE	PVC	GRAY
1	1	CABLE, DEV-NET, DROP, 4/22	PVC JACKET	GRAY

RELEASED EC NO: MNA2010-0073 DRAWN BY: DRWINRSTONE 2009/07/31 CHKD BY: WOODMAN APPR: J. MURPHY 2009/08/10	QUALITY SYMBOLS ▽=0 ▽=0	GENERAL TOLERANCES (UNLESS SPECIFIED)	DIMENSION STYLE IN/MM	SCALE 1.5:1	DESIGN UNITS INCH	THIRD ANGLE PROJECTION												
		<table border="1"> <thead> <tr> <th></th> <th>mm</th> <th>INCH</th> </tr> </thead> <tbody> <tr> <td>4 PLACES ±</td> <td>---</td> <td>±---</td> </tr> <tr> <td>3 PLACES ±</td> <td>---</td> <td>±---</td> </tr> <tr> <td>2 PLACES ±</td> <td>---</td> <td>±.01</td> </tr> <tr> <td>1 PLACE ±</td> <td>±0.3</td> <td>±---</td> </tr> </tbody> </table>		mm	INCH	4 PLACES ±	---	±---	3 PLACES ±	---	±---	2 PLACES ±	---	±.01	1 PLACE ±	±0.3	±---	DRAWN BY: R. STONE DATE: 2009/07/30
	mm	INCH																
4 PLACES ±	---	±---																
3 PLACES ±	---	±---																
2 PLACES ±	---	±.01																
1 PLACE ±	±0.3	±---																
DRAFT WHERE APPLICABLE MUST REMAIN WITHIN DIMENSIONS	SEE CHART	MATERIAL NO. SD-130025-023	DOCUMENT NO.	SHEET NO. 1 OF 1														
THIS DRAWING CONTAINS INFORMATION THAT IS PROPRIETARY TO MOLEX INCORPORATED AND SHOULD NOT BE USED WITHOUT WRITTEN PERMISSION																		