

REVISIONS					
P	LTR	DESCRIPTION	DATE	DMN	APVD
A		REVISED PER ECO-15-015252	13NOV15	BJ	FY
A1		REVISED PER ECO-16-003656	10MAR16	B.J.	S.Y.

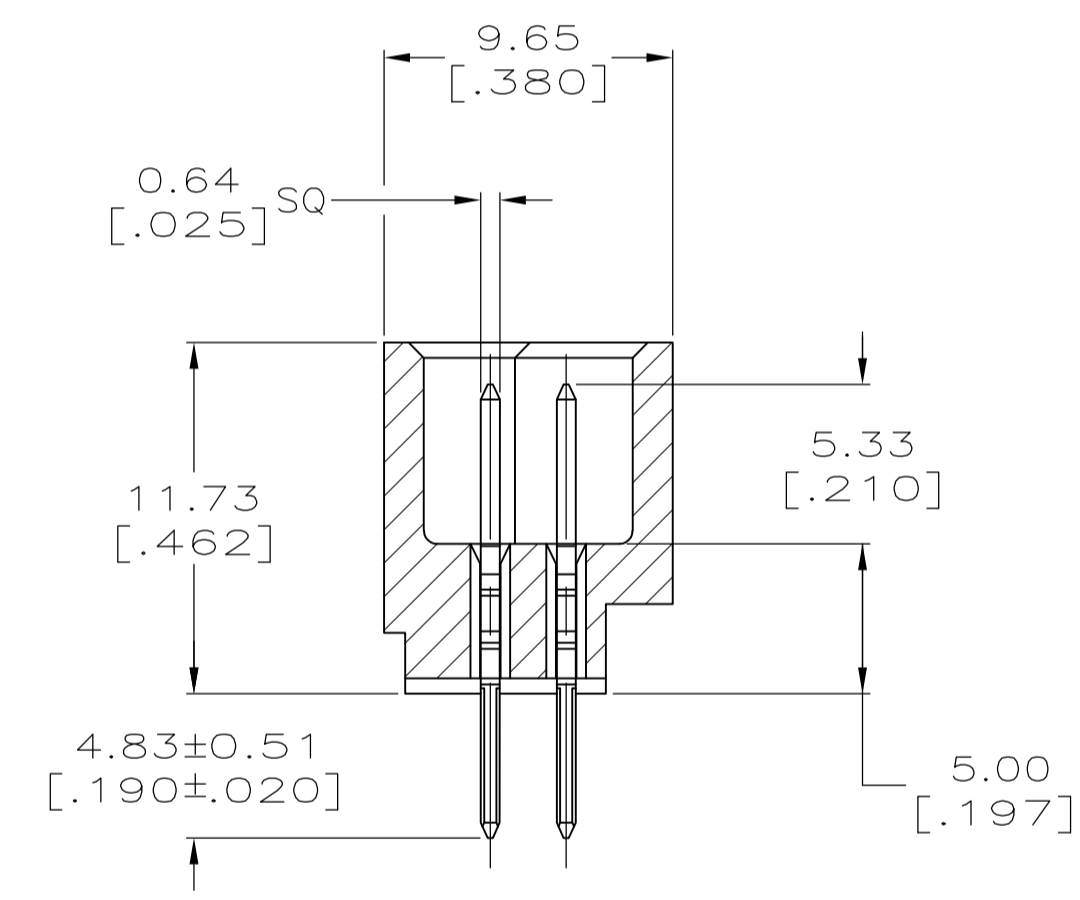

SECTION T-T

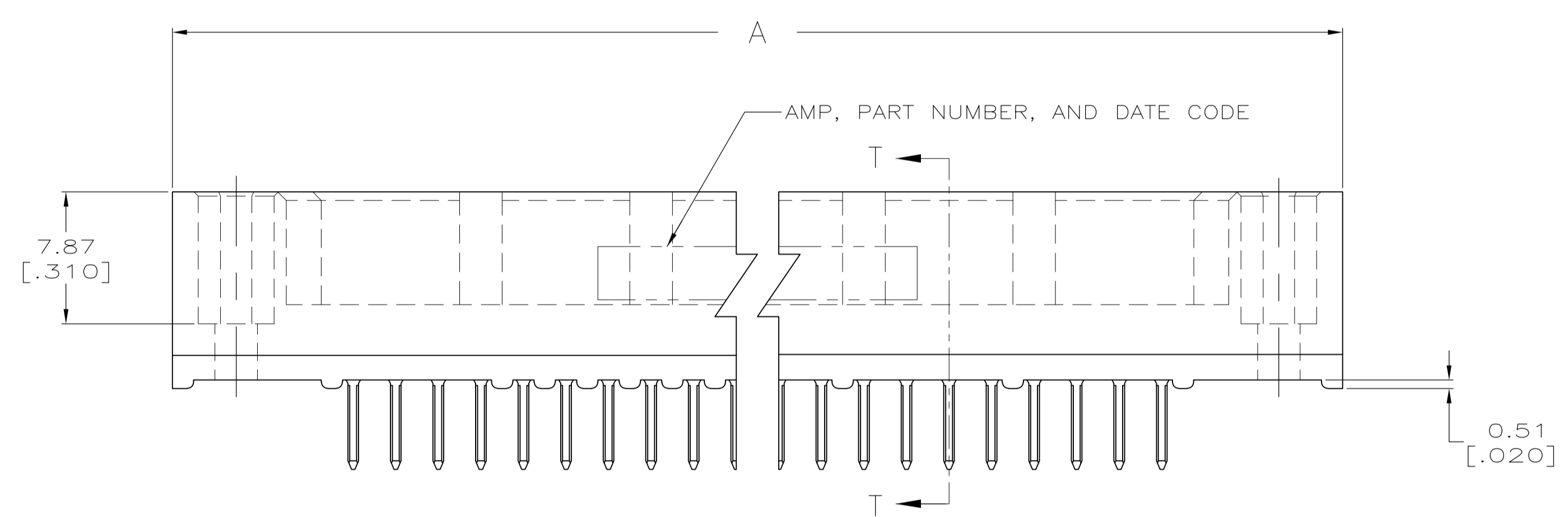
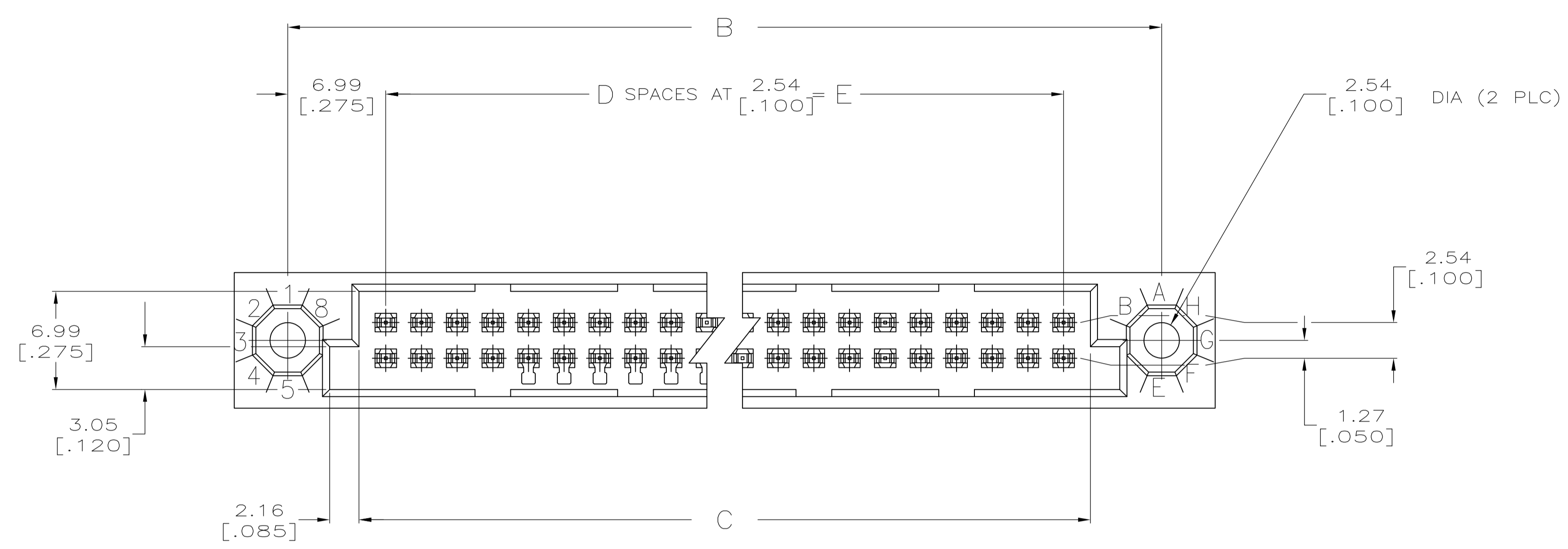
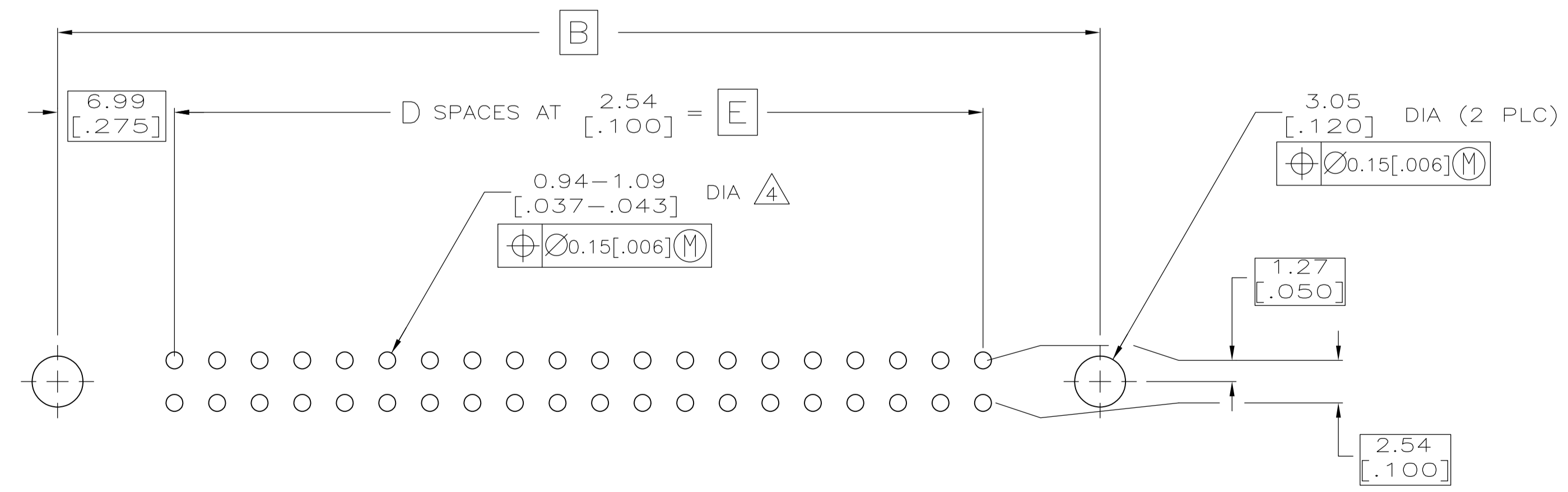

RECOMMENDED P.C. BOARD LAYOUT

THIS DRAWING IS A CONTROLLED DOCUMENT.		DIN J. POLIGNONE 18JUL05	TE Connectivity
DIMENSIONS: mm [INCHES]		CHK A. SHARPE 18JUL05	
TOLERANCES UNLESS OTHERWISE SPECIFIED:		APVD A. SHARPE 18JUL05	NAME ASSEMBLY, PIN, VERTICAL, HDI, LEAD-FREE, 2 ROW, WITHOUT GUIDES, 4.83[.190] SOLDER POSTS
0 PLC ± -	1 PLC ± -	2 PLC ± -	APPLICATION SPEC
3 PLC ± 0.13[.005]	4 PLC ± -	ANGLES ± -	SIZE A1
MATERIAL	FINISH	WEIGHT	CAGE CODE DRAWING NO. 00779C=5532430
CUSTOMER DRAWING		SCALE 4:1	SHEET 1 OF 2 REV A1

REVISIONS				
REV	BY	DESCRIPTION	DATE	APPV
-	-	SEE SHEET 1	-	-

- ① HOUSING MATERIAL: THERMOPLASTIC.
- ② CONTACT MATERIAL: COPPER ALLOY
- ③ FINISH:
MATING AREA: MEETS THE PERFORMANCE REQUIREMENTS OF PRODUCT SPECIFICATION 108-9063; BASED ON TELCORDIA DR-1217-CORE APPLICATIONS IN UNCONTROLLED ENVIRONMENTS.
TIN PLATED POSTS.
- ④ SOLDER PIN POST RECOMMENDED P.C. BOARD HOLE SIZES ARE 0.94-1.09 [.037-.043]; RECOMMENDED PAD DIA IS 1.52 [.060].
- ⑤ OBSOLETE PARTS: OBSOLETE CIS STREAMLINING PER D.RENAUD/D.SINISI

⑤ OBSOLETE	187.96 [7.400]	74	191.77 [7.550]	201.93 [7.950]	209.55 [8.250]	150	1-5532430-4
	137.16 [5.400]	54	140.97 [5.550]	151.13 [5.950]	158.75 [6.250]	110	1-5532430-0
⑤ OBSOLETE	73.66 [2.900]	29	77.47 [3.050]	87.63 [3.450]	95.25 [3.750]	60	5532430-5
	48.26 [1.900]	19	52.07 [2.050]	62.23 [2.450]	69.85 [2.750]	40	5532430-3
⑤ OBSOLETE	35.56 [1.400]	14	39.37 [1.550]	49.53 [1.950]	57.15 [2.250]	30	5532430-2
	E	D	C	B	A	POSN	PART NUMBER

THIS DRAWING IS A CONTROLLED DOCUMENT.		DIN J. POLIGNONE 23FEB05	 TE Connectivity
DIMENSIONS: mm [INCHES]		CIK A. SHARPE 18JUL05	
TOLERANCES UNLESS OTHERWISE SPECIFIED:		APVD A. SHARPE 18JUL05	NAME ASSEMBLY, PIN, VERTICAL, HDI, LEAD-FREE, 2 ROW, WITHOUT GUIDES, 4.83[.190] SOLDER POSTS
0 PLG ± -	1 PLG ± -	PRODUCT SPEC	RESTRICTED TO
2 PLG ± -	3 PLG ± 0.13 [.005]	APPLICATION SPEC	SIZE A1 00779
4 PLG ± -	ANGLES ± -	WEIGHT -	DRAWING NO. 5532430
MATERIAL	FINISH	CUSTOMER DRAWING	SCALE 4:1 SHEET 2 OF 2 REV A1