

Features

- High-speed, low-noise, non-inverting 1-10 buffer
- Maximum Frequency up to 250 MHz
- Low output skew < 60ps
- Low duty cycle distortion < 200ps
- Low propagation delay < 2.0ns
- Multiple V_{DD}, GND pins for noise reduction
- 1.8V or 2.5V supply voltage
- Packages (Pb-free & Green):
 - 20-pin, TSSOP (L20)
 - 20-pin, SSOP (H20)

Description

The PI6C10807 is a 1.8V, or 2.5V high-speed, low-noise 1-10 non-inverting clock buffer. The key goal in designing the PI6C10807 is to target networking applications that require low-skew, low-jitter, and high-frequency clock distribution.

Providing output-to-output skew as low as 60ps, the PI6C10807 is an ideal clock distribution device for synchronous systems. Designing synchronous networking systems requires a tight level of skew from a large number of outputs.

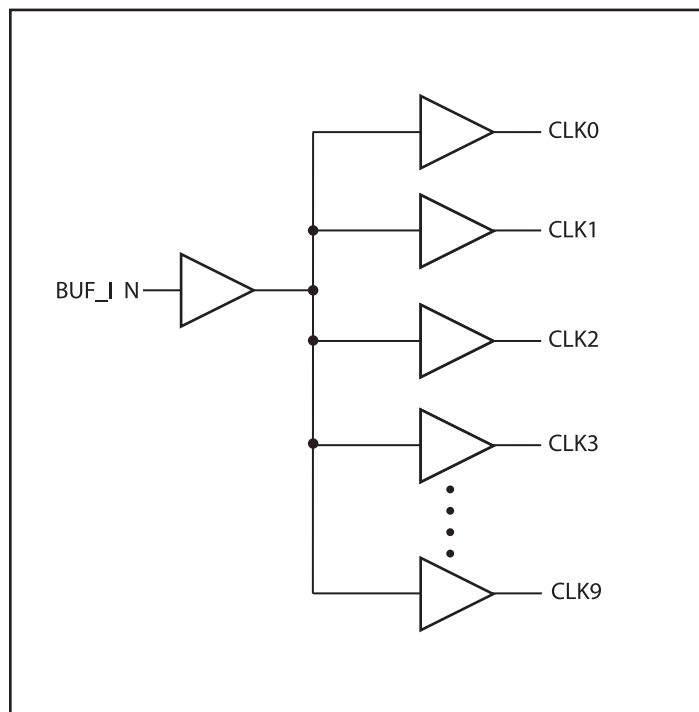
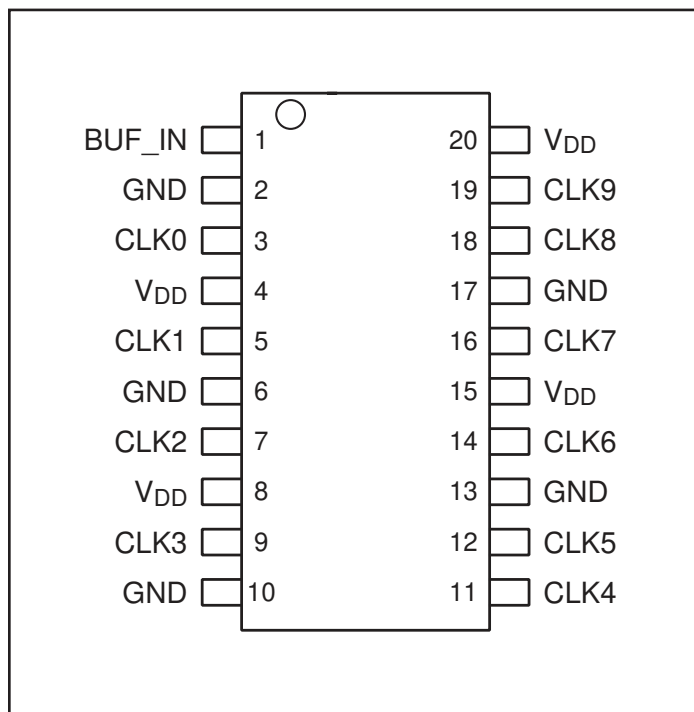
Block Diagram

Pin Configuration

Pin Description

Pin Name	Description
BUF_IN	Input
CLK [0:9]	Outputs
GND	Ground
V _{DD}	Power

2.5V Absolute Maximum Ratings (Above which the useful life may be impaired. For user guidelines only, not tested.)

Storage Temperature.....	-65°C to +150°C
V _{DD} Voltage	-0.5V to +3.6V
Output Voltage (max. 3.6V)	-0.5V to V _{DD} +0.5V
Input Voltage (max 3.6V).....	-0.5V to V _{DD} +0.5V

Note: Stresses greater than those listed under MAXIMUM RATINGS may cause permanent damage to the device. This is a stress rating only and functional operation of the device at these or any other conditions above those indicated in the operational sections of this specification is not implied. Exposure to absolute maximum rating conditions for extended periods may affect reliability.

2.5V DC Characteristics (Over Operating Range: V_{DD} = 2.5V ± 0.2V, T_A = -40° to 85°C)

Parameters	Description	Test Conditions ¹	Min.	Typ. ²	Max.	Units
V _{DD}	Supply Voltage		2.3	2.5	2.7	
V _{IH}	Input HIGH Voltage	Logic HIGH level	1.7		3.6	V
V _{IL}	Input LOW Voltage	Logic LOW level	-0.3		0.7	
I _I	Input Current	V _{DD} = Max, V _{in} = V _{DD} or GND			15	μA
V _{OH}	Output High Voltage	V _{DD} = Min., V _{IN} = V _{IH} or V _{IL}	I _{OH} = -1mA	2.0		V
			I _{OH} = -2mA	1.7		
			I _{OH} = -8mA	1.7		
V _{OL}	Output LOW Voltage	V _{DD} = Min., V _{IN} = V _{IH} or V _{IL}	I _{OL} = 1mA		0.1	V
			I _{OL} = 2mA		0.2	
			I _{OL} = 8mA		0.2	

Notes:

- For Max. or Min. conditions, use appropriate operating range values.
- Typical values are at V_{DD} = 2.5V, +25°C ambient and maximum loading.

2.5V AC Characteristics (Over Operating Range: V_{DD} = 2.5V ± 0.2V, T_A = -40° to 85°C)

Parameters	Description	Test Conditions ¹	Min.	Typ	Max.	Units	
F _{IN}	Input Frequency		0		250	MHz	
t _R /t _F	CLKn Rise/Fall Time	20% to 80%			1.0	ns	
t _{SK(P)} ^{3,5}	Pulse Skew between opposite transitions (t _{PHL} -t _{PLH}) of the same output	V _{in} > V _{DD} C _L = 5pF, 125 MHz		100	200	ps	
t _{PLH} , t _{PHL} ^{2,5}	Propagation Delay BUF_IN to CLKn	C _L = 5pF, 125 MHz	1.0	1.5	2.0	ns	
t _{SK(O)} ^{3,5}	Output to Output Skew between any two outputs of the same device @ same transition				60	ps	
t _{SK(T)} ^{3,5}	Part to Part Skew between two identical outputs of different parts on the same board ⁴				300		
t _{dc_in} ⁵	Duty Cycle In @ Ins edge rate			45		55	%
t _{dc_out} ⁵	Duty Cycle Out			40		57.5	

Notes:

- See test circuit and waveforms.
- Minimum limits are guaranteed but not tested on Propagation Delays.
- Skew measured at worst case temperature (max. temp).
- Identical conditions: loading, transitions, supply voltage, temperature, package type and speed grade.
- Outputs are measured at V_{DD}/2

1.8V Absolute Maximum Ratings (Above which the useful life may be impaired. For user guidelines only, not tested.)

Storage Temperature.....	-65°C to +150°C
V _{DD} Voltage	-0.5V to +2.5V
Output Voltage (max 2.5V)	-0.5V to V _{DD} +0.5V
Input Voltage (max 2.5V)	-0.5V to V _{DD} +0.5V

Note: Stresses greater than those listed under MAXIMUM RATINGS may cause permanent damage to the device. This is a stress rating only and functional operation of the device at these or any other conditions above those indicated in the operational sections of this specification is not implied. Exposure to absolute maximum rating conditions for extended periods may affect reliability.

1.8V DC Characteristics (Over Operating Range: V_{DD} = 1.8V ± 0.15V, T_A = -40° to 85°C)

Parameters	Description	Test Conditions ⁽¹⁾	Min.	Typ. ⁽²⁾	Max.	Units
V _{DD}	Supply Voltage		1.65	1.8	1.95	
V _{IH}	Input HIGH Voltage	Logic HIGH level	1.1		2.7	V
V _{IL}	Input LOW Voltage	Logic LOW level	-0.3		0.35*V _{DD}	
I _I	Input Current ⁽³⁾	V _{DD} = Max, V _{in} = V _{DD} or GND			15	μA
V _{OH}	Output High Voltage	V _{DD} = Min., V _{IN} = V _{IH} or V _{IL}	I _{OH} = -2mA	1.35		V
			I _{OH} = -8mA	1.2		
V _{OL}	Output LOW Voltage	V _{DD} = Min., V _{IN} = V _{IH} or V _{IL}	I _{OL} = 2mA		0.1	V
			I _{OL} = -8mA		0.2	

Notes:

- For Max. or Min. conditions, use appropriate operating V_{DD} and T_A values.
- Typical values are at V_{DD} = 1.8V, +25°C ambient and maximum loading.
- This parameter is determined by device characterization but is not production tested.

1.8V AC Characteristics (Over Operating Range: V_{DD} = 1.8V ± 0.15V, T_A = -40° to 85°C)

Parameters	Description	Test Conditions ⁽¹⁾	Min.	Typ	Max.	Units
F _{IN}	Input Frequency		0		180	MHz
t _r /t _f	CLKn Rise/Fall Time	20% to 80%			1.0	ns
t _{SK(P)} ^{3,5}	Pulse Skew between opposite transitions (t _{PHL} -t _{PLH}) of the same output	V _{in} > V _{DD} C _L = 5pF, 125 MHz		100	200	ps
t _{PLH, tPHL} ^{2,5}	Propagation Delay BUF_IN to CLKn	C _L = 5pF, 125 MHz	1.0	1.5	2.0	ns
t _{SK(O)} ^{3,5}	Output to Output Skew between any two outputs of the same device @ same transition				60	ps
t _{SK(T)} ^{3,5}	Part to Part Skew between two identical outputs of different parts on the same board ⁴				300	
t _{dc_in} ⁵	Duty Cycle In @ Ins edge rate		45		55	%
t _{dc_out} ⁵	Duty Cycle Out		40		57.5	

Notes:

- See test circuit and waveforms
- Minimum limits are guaranteed but not tested on Propagation Delays.
- Skew measured at worst case temperature (max. temp).
- Identical conditions: loading, transitions, supply voltage, temperature, package type and speed grade..
- Outputs are measured at V_{DD}/2

Power Supply Characteristics

Parameters	Description	Test Conditions ⁽¹⁾		Min.	Typ. ⁽²⁾	Max.	Units
I _{DDQ}	Quiescent Power Supply Current	V _{DD} = 2.7V	V _{IN} = GND or V _{DD}			10	μA
		V _{DD} = 1.95V				10	
I _{DDn}	Dynamic Power Supply Current per Output	V _{DD} = 2.7V	All Outputs Toggling, C _L = 5pF, F _{IN} = 125MHz		1.8		mA
		V _{DD} = 1.95V			3.5		
I _{DD_TOT}	Total Power Supply Current	V _{DD} = 2.7V	V _{IN} = V _{DD} or GND, All Outputs Toggling, C _L = 5pF, F _{IN} = 125MHz		48		
		V _{DD} = 1.95V			35		
ΔI _{CC}	Static Supply Current per inputs @ High Level	V _{DD} = 2.7V	V _{INx} = V _{DD} - 0.6V ⁽³⁾			500	μA
		V _{DD} = 1.95V	V _{INx} = V _{DD} - 0.6V ⁽³⁾			450	

Notes:

- For Max. or Min. conditions, use appropriate value specified under Electrical Characteristics.
- Typical values are at V_{DD} = 1.5V, 1.8V or 2.5V, and +25°C ambient.
- Per TTL driven input (V_{IN} = V_{DD} - 0.6V); all other inputs at V_{DD} or GND.

Capacitance (T_A = 25°C, f = 1 MHz)

Parameters ⁽¹⁾	Description	Test Conditions	Typ	Max.	Units
C _{IN}	Input Capacitance	V _{IN} = 0V	3.0	4	pF
C _{OUT}	Output Capacitance	V _{OUT} = 0V	—	6	

Note:

- This parameter is determined by device characterization but is not production tested.

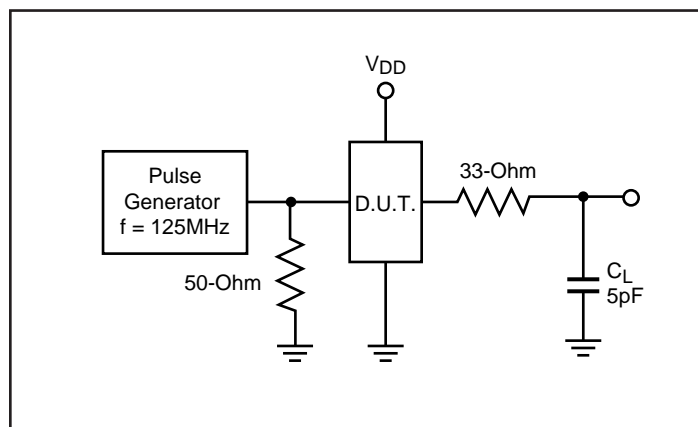
Test Circuits for All Outputs

Definitions:

C_L = Load capacitance: includes jig and probe capacitance.

Switching Waveforms

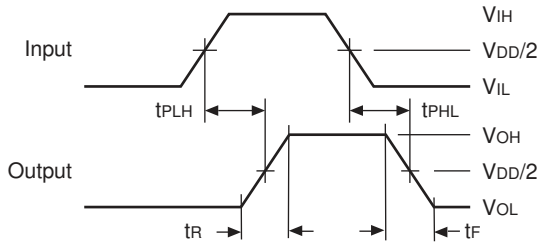
Propagation Delay



Pulse Skew – $t_{SK(P)}$

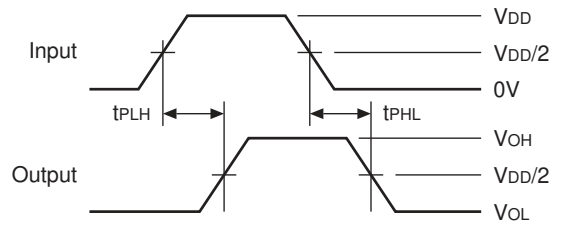

$$t_{SK(P)} = |t_{PLH} - t_{PHL}|$$

Output Skew – $t_{SK(O)}$

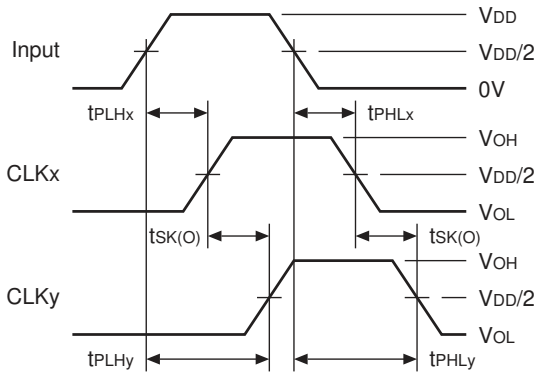

$$t_{SK(O)} = |t_{PLHy} - t_{PLHx}| \text{ or } |t_{PHLy} - t_{PHLx}|$$

Package Skew – $t_{SK(T)}$

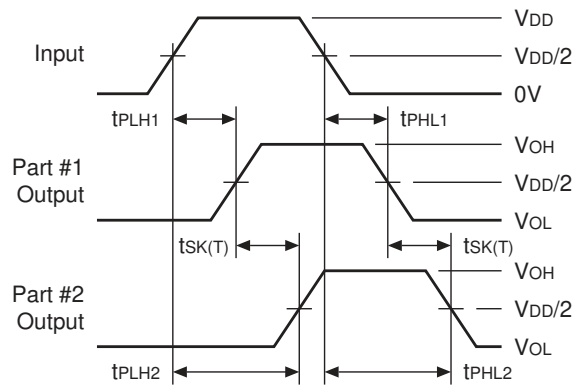

$$t_{SK(T)} = |t_{PLH2} - t_{PLH1}| \text{ or } |t_{PHL2} - t_{PHL1}|$$

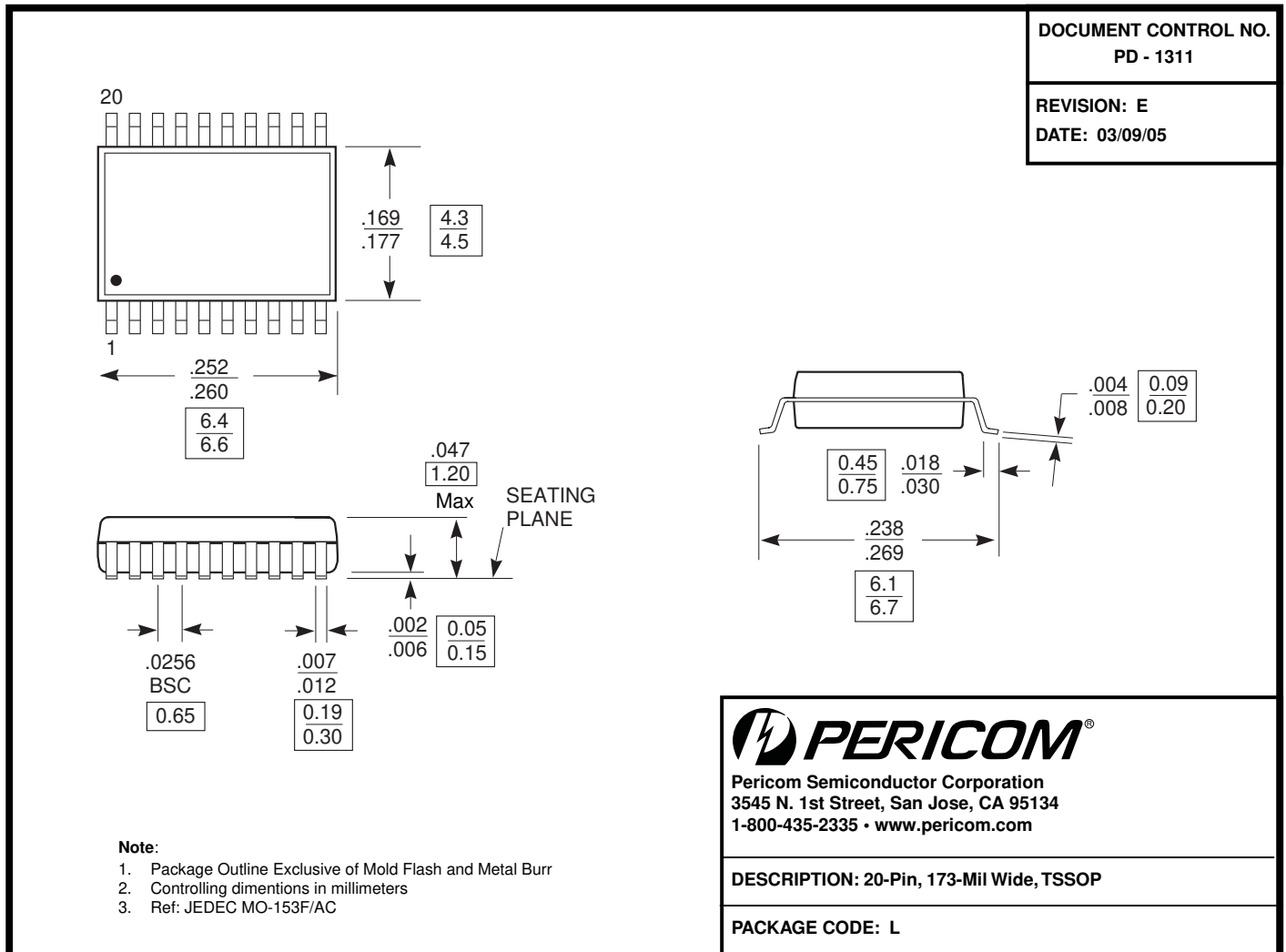
Packaging Mechanical: 20-pin, TSSOP (L)

Packaging Mechanical: 20-pin, SSOP (H)

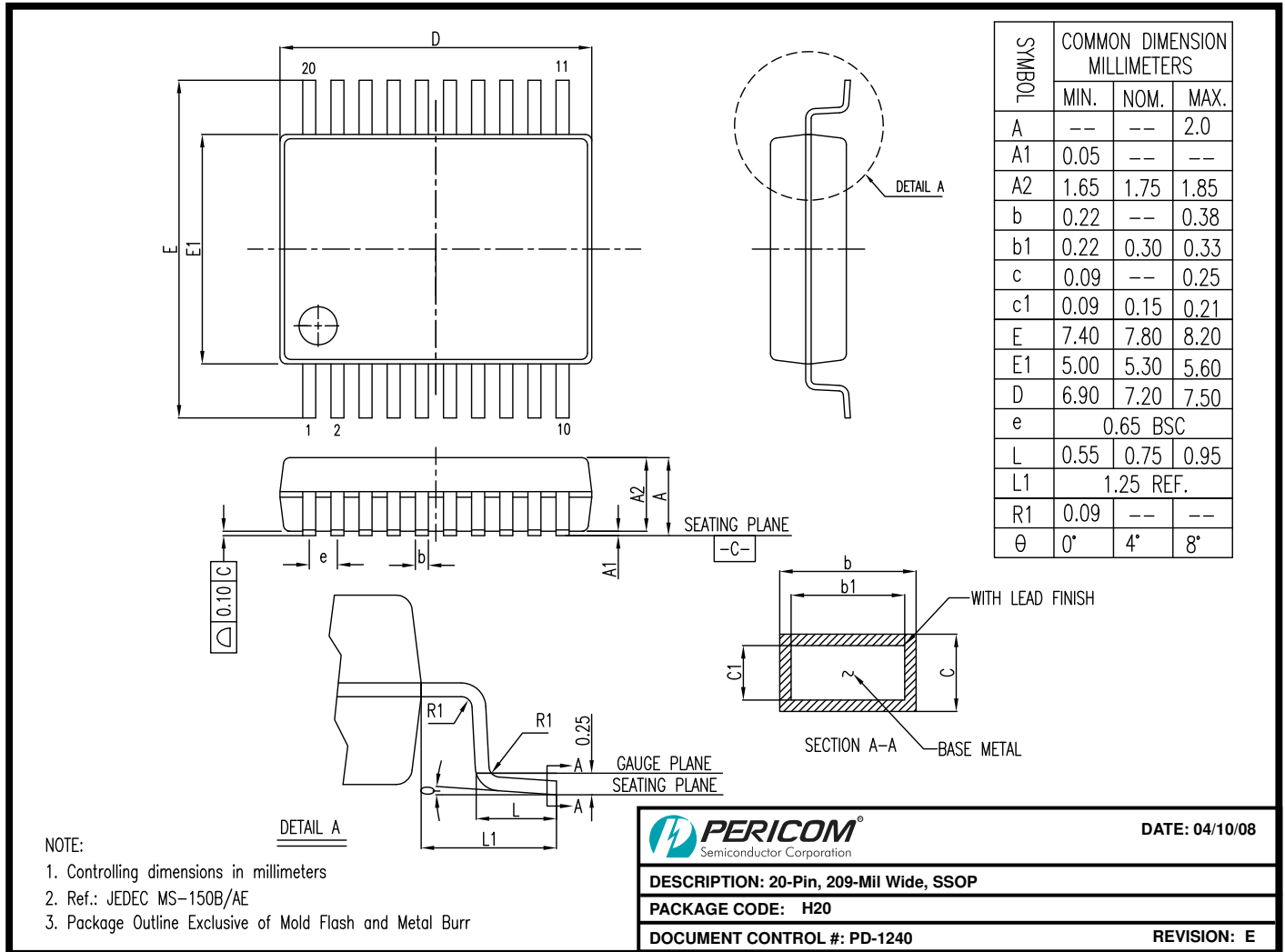

08-0140

Ordering Information⁽¹⁻³⁾

Ordering Code	Package Code	Package Type
PI6C10807LE	L	Pb-free & Green, 20-pin 173-mil wide TSSOP
PI6C10807HE	H	Pb-free & Green, 20-pin 209-mil wide SSOP

Notes:

1. Thermal Characteristics can be found on the web at www.pericom.com/packaging/
2. E = Lead-free and Green
3. Adding an X suffix = Tape/Reel