

PART NUMBER	REVISION	DESCRIPTION	FEED TYPE
2150381-1	C	FINE CRIMP HEIGHT ADJUST	MECHANICAL
2150381-2	C	FINE CRIMP HEIGHT ADJUST	PNEUMATIC
7-2150381-1	C	MECHANICAL AND CRIMP TOOLING KIT	MECHANICAL
7-2150381-2	C	PNEUMATIC AND CRIMP TOOLING KIT	PNEUMATIC
7-2150381-7	A	CRIMP TOOLING KIT	-

ATLANTIC VERSION TERMINATOR INTERFACE ADAPTER

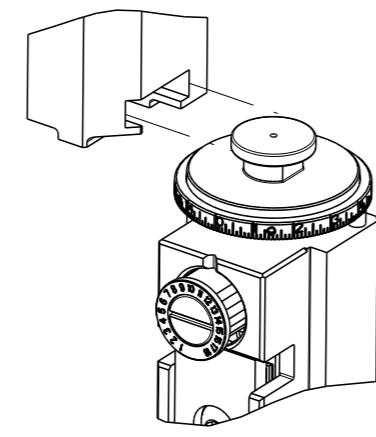

APPLICATOR DATA		
CRIMP	SIZE	TYPE
WIRE	3.05 mm [.120]	F
INSUL	3.56 mm [.140]	Ø
APPL INSTRUCTIONS 408-35043		

TERMINAL DATA: TE TERMINAL		TE CRIMP SPECIFICATION	
TERMINAL NAME: RING			
WIRE STRIP LENGTH		INSULATION DIAMETER RANGE	
2.79-3.56 mm [.110-.140 IN]		Ø1.91-2.79 mm [.075-.110 IN]	
TERMINAL APPLICATION SPECIFICATION	114-2084	-	-
TERMINALS APPLIED			
TE TERMINAL	TE TERMINAL	TE TERMINAL	TE TERMINAL
160344-1	160344-2	41406	41406-1
42065	42721-1	63514-1	

WIRE SIZE	CRIMP HEIGHT mm [INCH]	CRIMP HEIGHT REFERENCE SETTING
16 AWG	1.63 +/- 0.05 [0.064 +/- .002]	6.3
18 AWG	1.50 +/- 0.05 [0.059 +/- .002]	7.7
20 AWG	1.45 +/- 0.05 [0.057 +/- .002]	8.2

- RECOMMENDED SPARE PARTS
 - REFER TO SUPPLIED INSTRUCTION SHEET FOR CLEANING, LUBRICATION AND STORAGE OF APPLICATOR.
 - APPLY PART NUMBER 2-23419-6 LOCTITE TO THREADS OF ITEM 242.
 - CRIMP HEIGHT REFERENCE SETTING WAS THE SETTING USED WHEN THE APPLICATOR WAS QUALIFIED AT THE FACTORY. ADJUSTMENT MAY BE NECESSARY WHEN RUNNING APPLICATOR IN THE FIELD.
 - THE RECOMMENDED SET-UP FOR END FEED APPLICATORS IS POST-FEED WITH ITEM 2119653-1. THE APPLICATOR CAN BE CONFIGURED FOR PRE-FEED WITH ITEM 2119652-1 BUT MAY ENCOUNTER PROBLEMS WITH SOME APPLICATIONS. FEED ISSUES OR TERMINAL JAMMING MAY OCCUR IN THE PRE-FEED CONFIGURATION.
 - WIRE BARREL SEAM DOES NOT FULLY CLOSE ON 16 AWG WIRE SIZE, THEREFORE USE OF THIS WIRE SIZE IS NOT RECOMMENDED BY A.T. HOWEVER, IS APPROVED BY TERMINAL PRODUCT ENGINEER.
 - TERMINAL LUBRICANT IS RECOMMENDED.
8. UNLESS SPECIFIED OTHERWISE TORQUE VALUES SHALL BE USED PER DOCUMENT, 101-35000.

***WARNING**
ON INSTALLATION, SET WIRE DISC TO CRIMP HEIGHT REFERENCE SETTING FOR LARGEST WIRE SIZE. CRIMP HEIGHT REFERENCE SETTINGS GREATER THAN THE VALUE SHOWN MAY CAUSE DAMAGE TO THE CRIMP TOOLING, REFER TO THE INSTRUCTION SHEET FOR PROPER SETUP AND ADJUSTMENTS.

ATLANTIC VERSION
Shown on sheets 1 of 4 & 2 of 4
(Pacific version shown on sheets 3 of 4 & 4 of 4)

LOC	DIST	REVISIONS					
		#	LY#	DESCRIPTION	DATE	OWN	APVD
A	66	A		RELEASED	15NOV2013	LG	TE
		B		ECR-17-002055	17FEB2017	TB	TE
		C		ECR-19-000344	09JAN2020	FJ	TE

-	1	-	1	-	2119641-1	FEED CAM, AIR FEED	248	
-	1	1	1	1	2119082-9	CAM, SNAIL, INSULATION ADJUSTMENT	244	
-	1	1	1	1	2079764-1	WASHER, WAVE SPRING, CREST-TO-CREST	243	
-	1	1	1	1	2119083-1	RETAINER, INSULATION DIAL	242	
-	-	1	-	1	2119580-1	MECHANICAL FEED ASSEMBLY	239	
-	1	-	1	-	2844940-3	AIR FEED MODULE	238	
-	1	1	1	1	1-18028-0	WASHER, FLAT, REG M8	192	
-	REF	REF	REF	REF	994970-2	COUNTER, MAGNETIC	164	
-	1	1	1	1	2119955-2	ASSY, LUBRICATOR, END FEED	84	
-	1	1	1	1	455888-4	SPACER, CRIMPER	82	
-	1	1	1	1	1803607-4	DOCUMENTATION PACKAGE	71	
-	2	2	2	2	2-18032-2	SCR, SET, FLT PNT, M3 X 10.0	70	
-	1	1	1	1	2119740-1	TAG, IDENTIFICATION	67	
-	2	2	2	2	2168078-1	SCREW, DRIVE, RH, RoHS, 2 x .188	66	
-	1	1	1	1	2168083-2	SCR, SKT HD CAP, RoHS, M4 X 8.0	60	
-	1	1	1	1	5-18022-5	SCR, HEX HD CAP, M4 X 6.0	59	
-	-	1	-	1	2063961-1	FEED FINGER	58	
-	4	4	4	4	2168400-4	SHCS, LOW HEAD, RoHS, M4 X 8	57	
-	2	2	2	2	1-2168083-4	SCR, SKT HD CAP, RoHS, M4 X 5	56	
-	2	2	2	2	5018030-1	NUT, HEX, REG, RoHS, M3	54	
-	2	2	2	2	986965-8	NUT, LOCK, HEX, TORQUE (M4)	53	
-	1	-	1	-	2063961-9	FEED FINGER	51	
-	1	2	1	2	18023-9	SCR, SKT HD CAP M4 X 6.0	49	
-	-	1	-	1	2119652-1	FEED CAM, PRE FEED	48	
-	-	1	-	1	2119653-1	FEED CAM, POST FEED	47	
-	1	1	1	1	2119655-5	APPLICATOR BASIC ASSEMBLY, EF	46	
-	1	1	1	1	1803517-1	RAM ASSEMBLY, EF ATLANTIC	44	
-	1	1	1	1	1803602-1	SCR, BHSC, RoHS (M8 X 25)	41	
-	8	8	8	8	1-18028-2	WASHER, FLAT, REG M4	33	
-	2	2	2	2	2168083-9	SCR, SKT HD CAP, RoHS, M4 X 20	31	
-	2	2	2	2	2168083-2	SCR, SKT HD CAP, RoHS, M4 X 8.0	29	
-	1	1	1	1	240639-1	STRIPPER (MACHINING)	27	
-	2	2	2	2	1-2168083-5	SCR, SKT HD CAP, RoHS, M4 X 30	25	
-	1	1	1	1	1752371-1	PLATE, STRIP GUIDE	24	
-	2	2	2	2	2-22281-3	SPRING, COMPRESSION	22	
-	1	1	1	1	1803292-4	DRAG	20	
-	1	1	1	1	1901696-9	STRIP GUIDE, REAR	19	
-	1	1	1	1	1901695-9	STRIP GUIDE, FRONT	18	
-	4	4	4	4	1-2079383-1	SCR, BHSC, RoHS (M6 X 12)	17	
-	1	1	1	1	240644-1	PLATE, REAR SHEAR	11	
-	-	-	-	-	-	-	10	
-	1	1	1	1	690482-1	PLATE, FRONT SHEAR	9	
-	1	2	2	1	1	2-1333220-4	ANVIL, COMBINATION, .120	8
-	1	1	1	1	2217206-1	BLADE, SLUG	7	
-	-	-	-	-	-	-	6	
-	1	1	1	1	1-240641-7	SPACER	5	
-	1	1	1	1	3-238011-1	BLOCK, CRIMPER SPACER	4	
-	1	2	2	1	1	1633965-9	CRIMPER, INSULATION 0 PREMIUM	3
-	1	1	1	1	455888-4	SPACER, CRIMPER	2	
-	1	2	2	1	1	456409-2	CRIMPER, WIRE .120 "F" PREMIUM	1
-	77	72	71	2	-1	PART NO	DESCRIPTION	ITEM NO

<small>THE INFORMATION CONTAINED HEREIN IS UNCLASSIFIED EXCEPT WHERE SHOWN OTHERWISE. IT IS SUBJECT TO CHANGE AND WITHOUT WARRANTY OF ACCURACY OR COMPLETION. IT SHOULD BE CONTACTED FOR THE LATEST REVISION.</small>		DWN G. BAILEY M. CLIFFORD PRODUCT SPEC APPLICATION SPEC WEIGHT SCALE 1:1	14OCT2013 14OCT2013 14OCT2013 14OCT2013 00779 C=2150381 SHEET 1 OF 4	TE Connectivity Harrisburg, PA 17105-3608 Ocean End Feed Applicator Customer Accessible Production Drawing	RESTRICTED TO REV C
---	--	--	--	--	------------------------

LOC	DIST	REVISIONS			
A	66	REV	DATE	OWN	APVD
		-	SEE SHEET 1	-	-

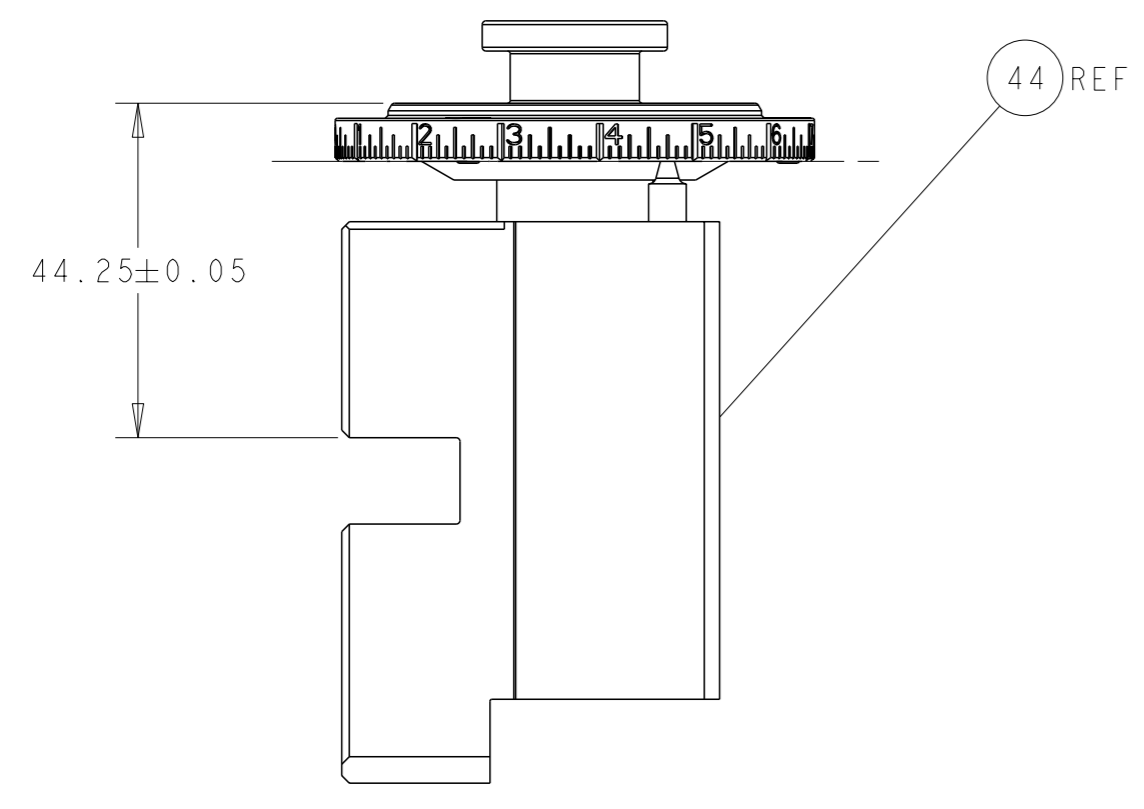

RAM SET-UP

FEED TYPE
MECHANICAL

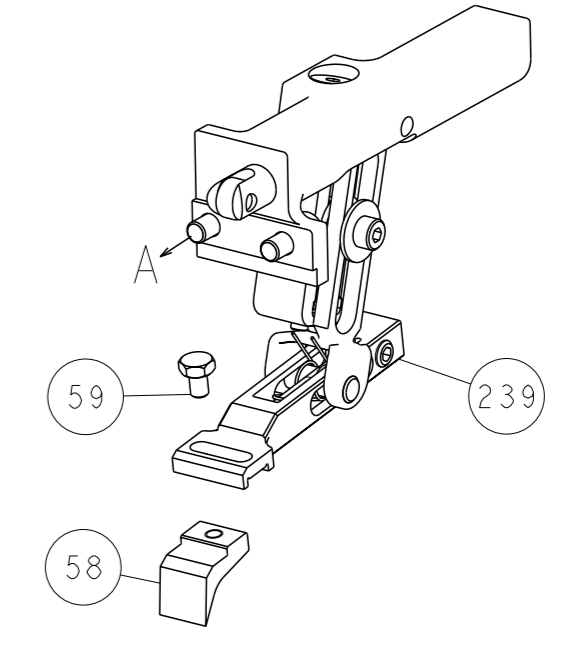

PNEUMATIC

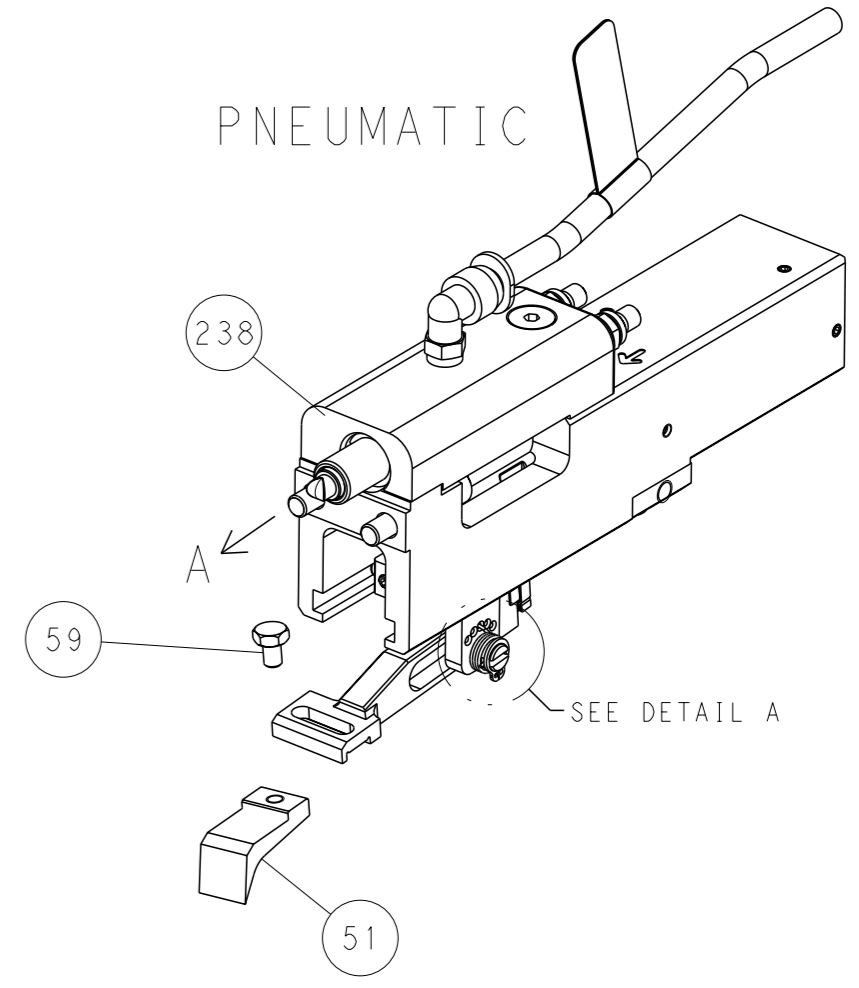

FEED SPRING
SETTING POSITION

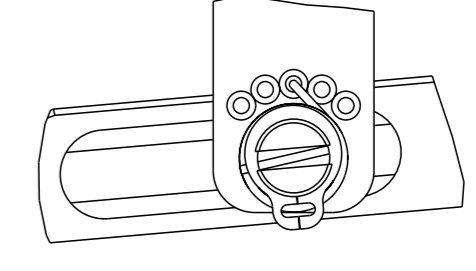

DETAIL A

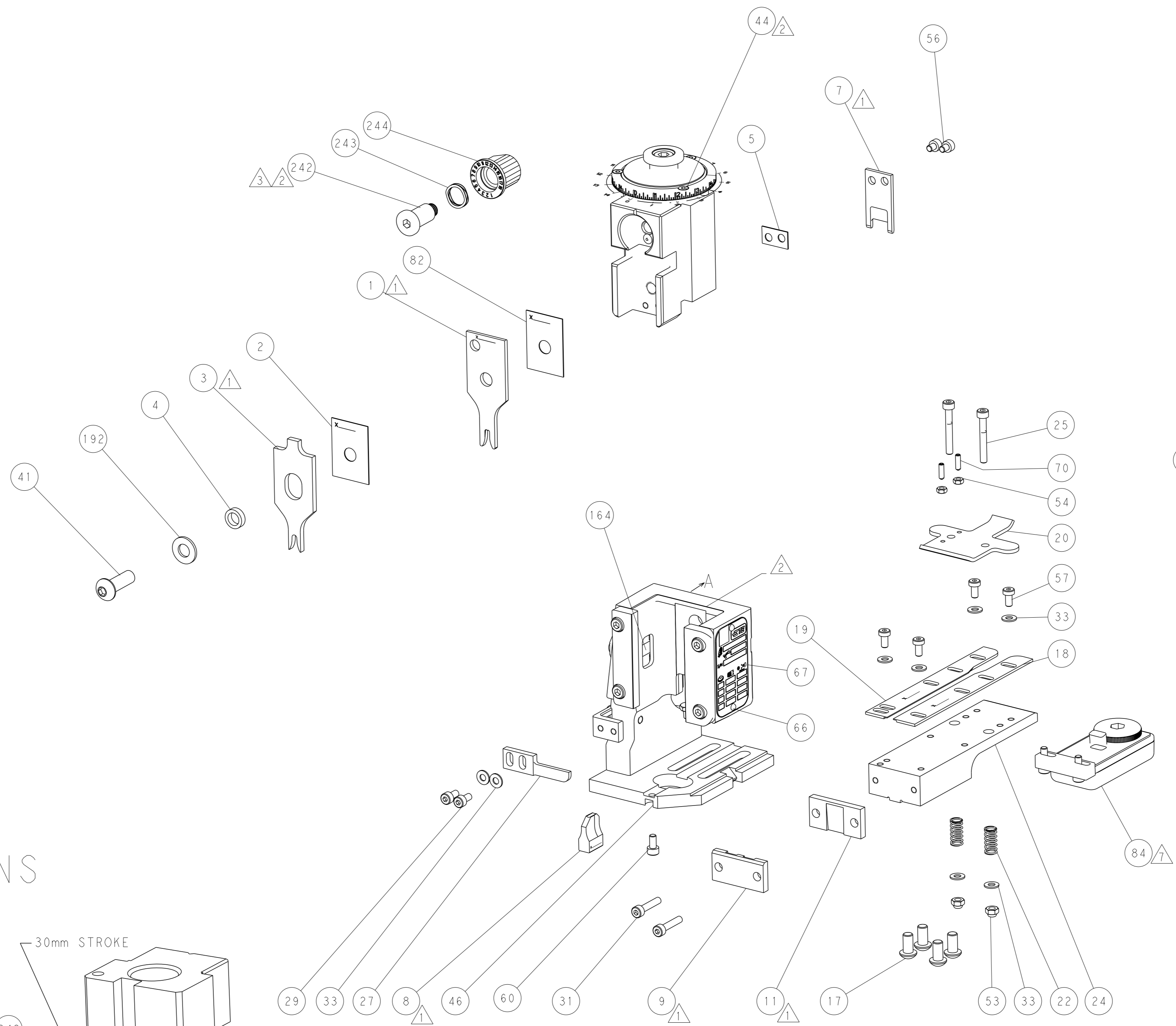

CAM POSITIONS

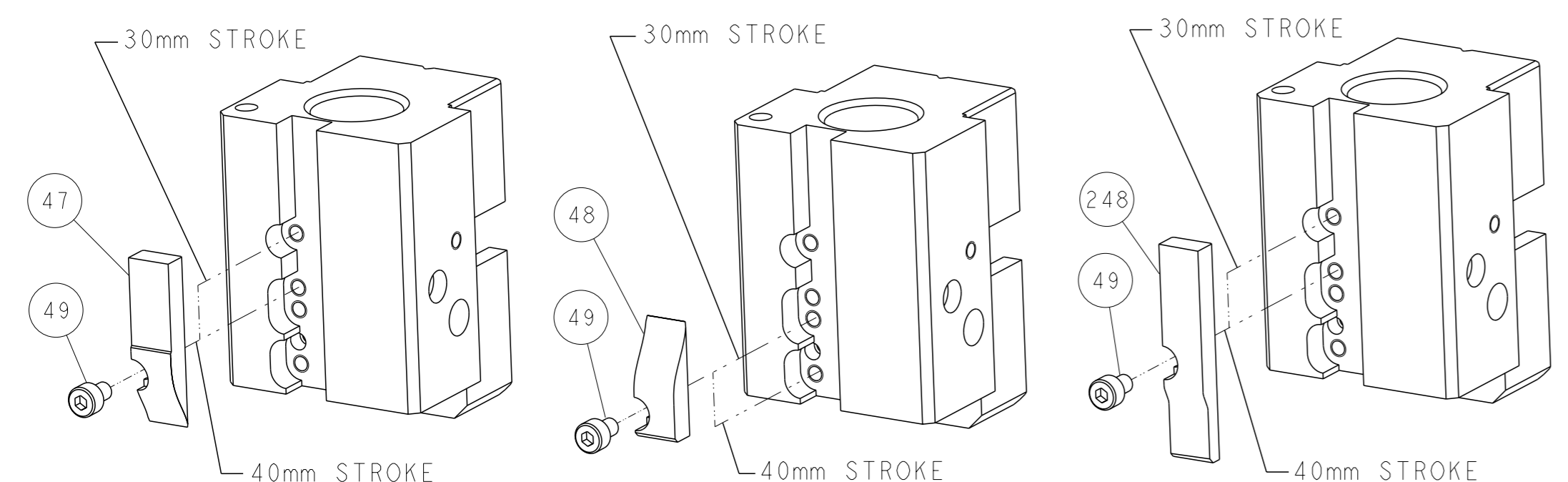

MECHANICAL POST FEED

MECHANICAL PRE FEED

AIR FEED

ATLANTIC VERSION
 Shown on sheets 1 of 4 & 2 of 4
 (Pacific version shown on sheets 3 of 4 & 4 of 4)

<small>THIS DRAWING IS A CONTROLLED DOCUMENT FOR TYCO ELECTRONICS CORPORATION. IT IS SUBJECT TO CHANGE AND THE CONTROL AND EXISTING DISCRETION SHOULD BE CONTACTED FOR THE LATEST REVISION.</small>		DWN L. GROSS 14OCT2013 CHK G. BAILEY 14OCT2013 APVD M. CLIFFORD 14OCT2013	TE Connectivity Harrisburg, PA 17105-3608
DIMENSIONS: mm TOLERANCES UNLESS OTHERWISE SPECIFIED: 0 PLC ± 1 PLC ± 2 PLC ± 3 PLC ± 4 PLC ± ANGLES FINISH *		NAME Ocean End Feed Applicator SIZE CAGE CODE DRAWING NO. A1 00779 C=2150381 WEIGHT -	RESTRICTED TO SCALE 1:1 SHEET 2 OF 4 REV C
MATERIAL:		Customer Accessible Production Drawing	

PART NUMBER	REVISION	DESCRIPTION	FEED TYPE
2-2150381-1	C	FINE CRIMP HEIGHT ADJUST	MECHANICAL
2-2150381-2	C	FINE CRIMP HEIGHT ADJUST	PNEUMATIC
7-2150381-7	A	CRIMP TOOLING KIT	-

PACIFIC VERSION TERMINATOR
INTERFACE ADAPTER

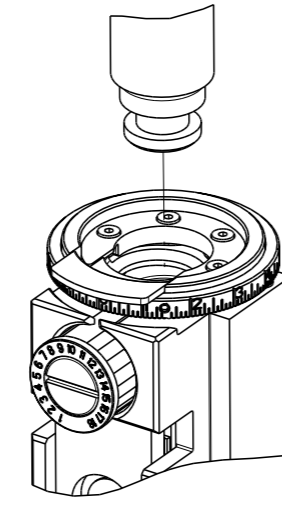

APPLICATOR DATA		
CRIMP	SIZE	TYPE
WIRE	3.05 mm [.120]	F
INSUL	3.56 mm [.140]	O
APPL INSTRUCTIONS 408-35043		

TERMINAL DATA: TE TERMINAL		TE CRIMP SPECIFICATION	
TERMINAL NAME: RING			
WIRE STRIP LENGTH 2.79-3.56 mm [.110-.140 IN]		INSULATION DIAMETER RANGE Ø1.91-2.79 mm [.075-.110 IN]	
TERMINAL APPLICATION SPECIFICATION	114-2084	-	-
TERMINALS APPLIED			
TE TERMINAL	TE TERMINAL	TE TERMINAL	TE TERMINAL
160344-1	160344-2	41406	41406-1
42065	42721-1	63514-1	

WIRE SIZE	CRIMP HEIGHT mm [INCH]	CRIMP HEIGHT REFERENCE SETTING
16 AWG	1.63 +/- 0.05 [.064 +/- .002]	6.3
18 AWG	1.50 +/- 0.05 [.059 +/- .002]	7.7
20 AWG	1.45 +/- 0.05 [.057 +/- .002]	8.2

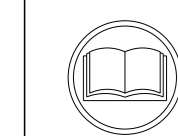

1. RECOMMENDED SPARE PARTS
2. REFER TO SUPPLIED INSTRUCTION SHEET FOR CLEANING, LUBRICATION AND STORAGE OF APPLICATOR.
3. APPLY PART NUMBER 2-23419-6 LOCTITE TO THREADS OF ITEM 242.
4. CRIMP HEIGHT REFERENCE SETTING WAS THE SETTING USED WHEN THE APPLICATOR WAS QUALIFIED AT THE FACTORY. ADJUSTMENT MAY BE NECESSARY WHEN RUNNING APPLICATOR IN THE FIELD.
5. THE RECOMMENDED SET-UP FOR END FEED APPLICATORS IS POST-FEED WITH ITEM 2119653-1. THE APPLICATOR CAN BE CONFIGURED FOR PRE-FEED WITH ITEM 2119652-1 BUT MAY ENCOUNTER PROBLEMS WITH SOME APPLICATIONS. FEED ISSUES OR TERMINAL JAMMING MAY OCCUR IN THE PRE-FEED CONFIGURATION.
6. WIRE BARREL SEAM DOES NOT FULLY CLOSE ON 16 AWG WIRE SIZE, THEREFORE USE OF THIS WIRE SIZE IS NOT RECOMMENDED BY A.T. HOWEVER, IS APPROVED BY TERMINAL PRODUCT ENGINEER.
7. TERMINAL LUBRICANT IS RECOMMENDED.
8. UNLESS SPECIFIED OTHERWISE TORQUE VALUES SHALL BE USED PER DOCUMENT, 101-35000.

***WARNING**
ON INSTALLATION, SET WIRE DISC TO CRIMP HEIGHT REFERENCE SETTING FOR LARGEST WIRE SIZE. CRIMP HEIGHT REFERENCE SETTINGS GREATER THAN THE VALUE SHOWN MAY CAUSE DAMAGE TO THE CRIMP TOOLING, REFER TO THE INSTRUCTION SHEET FOR PROPER SETUP AND ADJUSTMENTS.

PACIFIC VERSION
Shown on sheets 3 of 4 & 4 of 4
(Atlantic version shown on sheets 1 of 4 & 2 of 4)

LOC	DIST	REVISIONS					
A	66	P	LY#	DESCRIPTION	DATE	OWN	APVD
		-		SEE SHEET 1		-	-

-	1	1	2119082-9	CAM, SNAIL, INSULATION ADJUSTMENT	244
-	1	1	2079764-1	WASHER, WAVE SPRING, CREST-TO-CREST	243
-	1	1	2119083-1	RETAINER, INSULATION DIAL	242
-	-	1	2119580-1	MECHANICAL FEED ASSEMBLY	239
-	1	-	2844940-3	AIR FEED MODULE	238
-	1	1	1-18028-0	WASHER, FLAT, REG M8	192
-	4	4	2079383-9	SCR, BHSC, RoHS (M6 X 20)	186
-	REFREF		994970-2	COUNTER, MAGNETIC	164
-	1	-	2119641-2	FEED CAM, AIR FEED	152
-	1	1	2168083-8	SCR, SKT HD CAP, RoHS, M4 X 16	144
-	-	1	2119653-2	FEED CAM, POST FEED	142
-	1	1	2119655-6	APPLICATOR BASIC ASSEMBLY, EF	141
-	1	1	1803518-1	RAM ASSEMBLY, EF PACIFIC	140
-	1	1	2119955-2	ASSY, LUBRICATOR, END FEED	84
-	1	1	455888-4	SPACER, CRIMPER	82
-	1	1	1803607-4	DOCUMENTATION PACKAGE	71
-	2	2	2-18032-2	SCR, SET, FLT PNT, M3 X 10.0	70
-	1	1	2119740-1	TAG, IDENTIFICATION	67
-	2	2	2168078-1	SCREW, DRIVE, RH, RoHS, 2 x .188	66
-	1	1	5-18022-5	SCR, HEX HD CAP, M4 X 6.0	59
-	-	1	2063961-1	FEED FINGER	58
-	4	4	2168400-4	SHCS, LOW HEAD, RoHS, M4 X 8	57
-	2	2	1-2168083-4	SCR, SKT HD CAP, RoHS, M4 X 5	56
-	2	2	5018030-1	NUT, HEX, REG, RoHS, M3	54
-	2	2	986965-8	NUT, LOCK, HEX, TORQUE (M4)	53
-	1	-	2063961-9	FEED FINGER	51
-	1	2	18023-9	SCR, SKT HD CAP M4 X 6.0	49
-	-	1	2119652-1	FEED CAM, PRE FEED	48
-	1	1	1803602-1	SCR, BHSC, RoHS (M8 X 25)	41
-	8	8	1-18028-2	WASHER, FLAT, REG M4	33
-	2	2	2168083-9	SCR, SKT HD CAP, RoHS, M4 X 20	31
-	2	2	2168083-2	SCR, SKT HD CAP, RoHS, M4 X 8.0	29
-	1	1	240639-1	STRIPPER (MACHINING)	27
-	2	2	1-2168083-5	SCR, SKT HD CAP, RoHS, M4 X 30	25
-	1	1	1752371-1	PLATE, STRIP GUIDE	24
-	2	2	2-22281-3	SPRING, COMPRESSION	22
-	1	1	1803292-4	DRAG	20
-	1	1	1901696-9	STRIP GUIDE, REAR	19
-	1	1	1901695-9	STRIP GUIDE, FRONT	18
-	1	1	240644-1	PLATE, REAR SHEAR	11
-	-	-	-	-	10
-	1	1	690482-1	PLATE, FRONT SHEAR	9
1	1	1	2-1333220-4	ANVIL, COMBINATION, .120	8
-	1	1	2217206-1	BLADE, SLUG	7
-	-	-	-	-	6
-	1	1	1-240641-7	SPACER	5
-	1	1	3-238011-1	BLOCK, CRIMPER SPACER	4
1	1	1	1633965-9	CRIMPER, INSULATION O PREMIUM	3
-	1	1	455888-4	SPACER, CRIMPER	2
1	1	1	456409-2	CRIMPER, WIRE .120 "F" PREMIUM	1
-	77-22-21		PART NO	DESCRIPTION	ITEM NO

DIMENSIONS:		TOLERANCES UNLESS OTHERWISE SPECIFIED:		MATERIAL:	
mm	0 PLC ±	1 PLC ±	2 PLC ±	3 PLC ±	4 PLC ±
	ANGLES	FINISH			

OWN	14OCT2013	TE Connectivity
CHK	14OCT2013	Harrisburg, PA 17105-3608
APVD	14OCT2013	
NAME	Ocean End Feed Applicator	
SIZE	CAGE CODE	DRAWING NO
A1	00779	2150381
Customer Accessible Production Drawing	SCALE	1:1 SHEET 3 of 4 REV C

LOC	DIST	REVISIONS			
A	66	REV	DATE	OWN	APVD
-	-	SEE SHEET 1	-	-	-

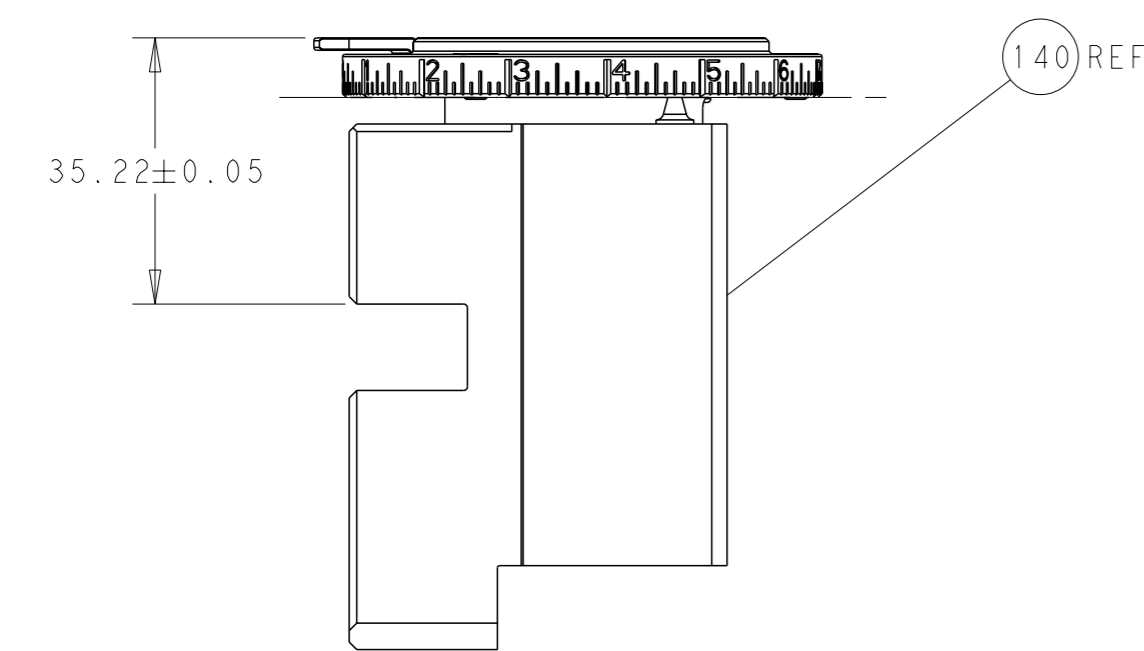

RAM SET-UP

FEED TYPE
MECHANICAL

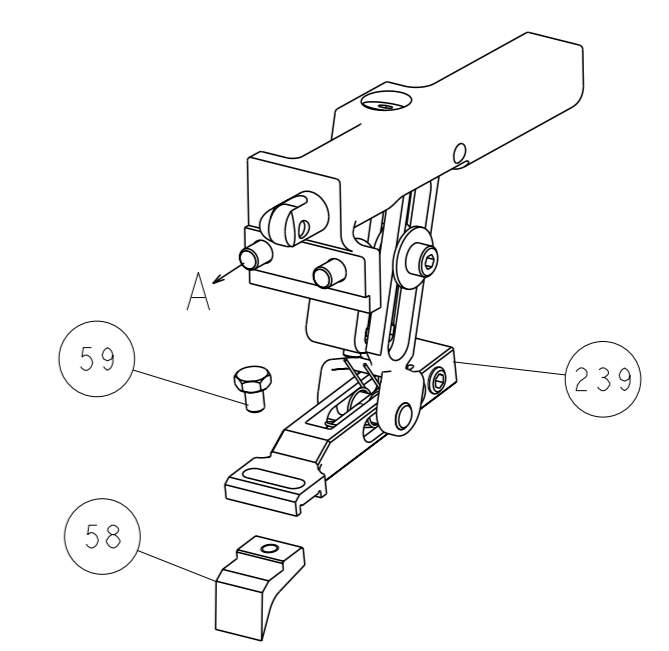

PNEUMATIC

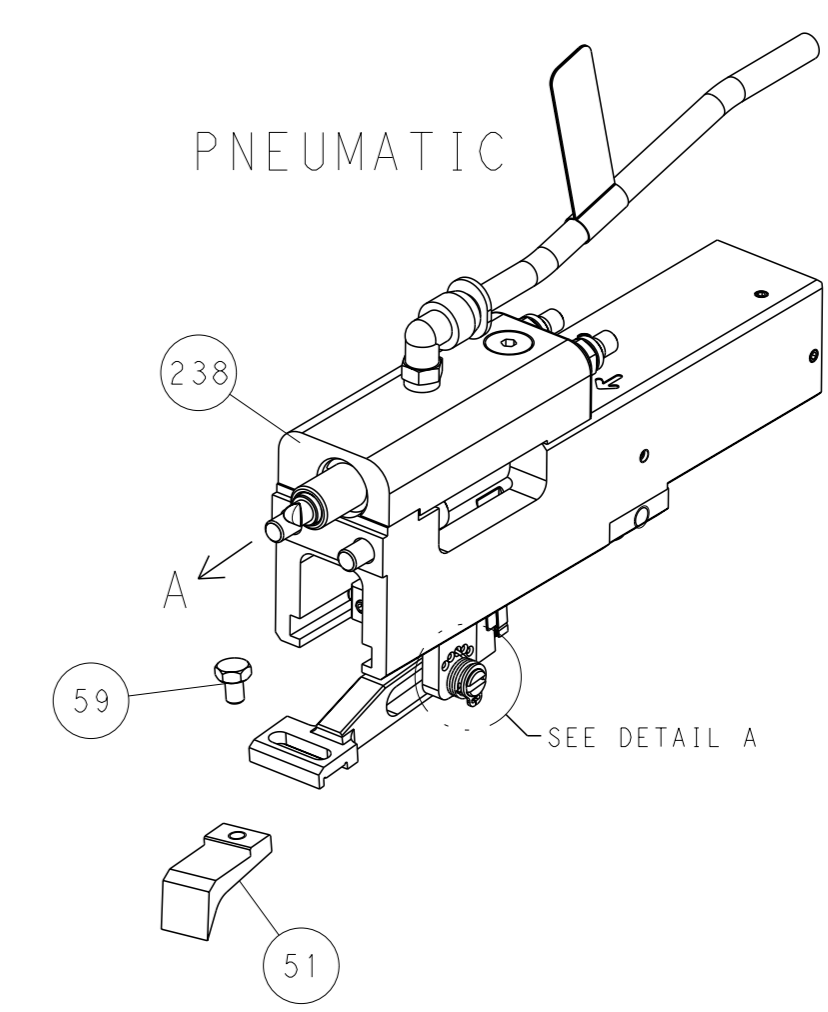

FEED SPRING
SETTING POSITION

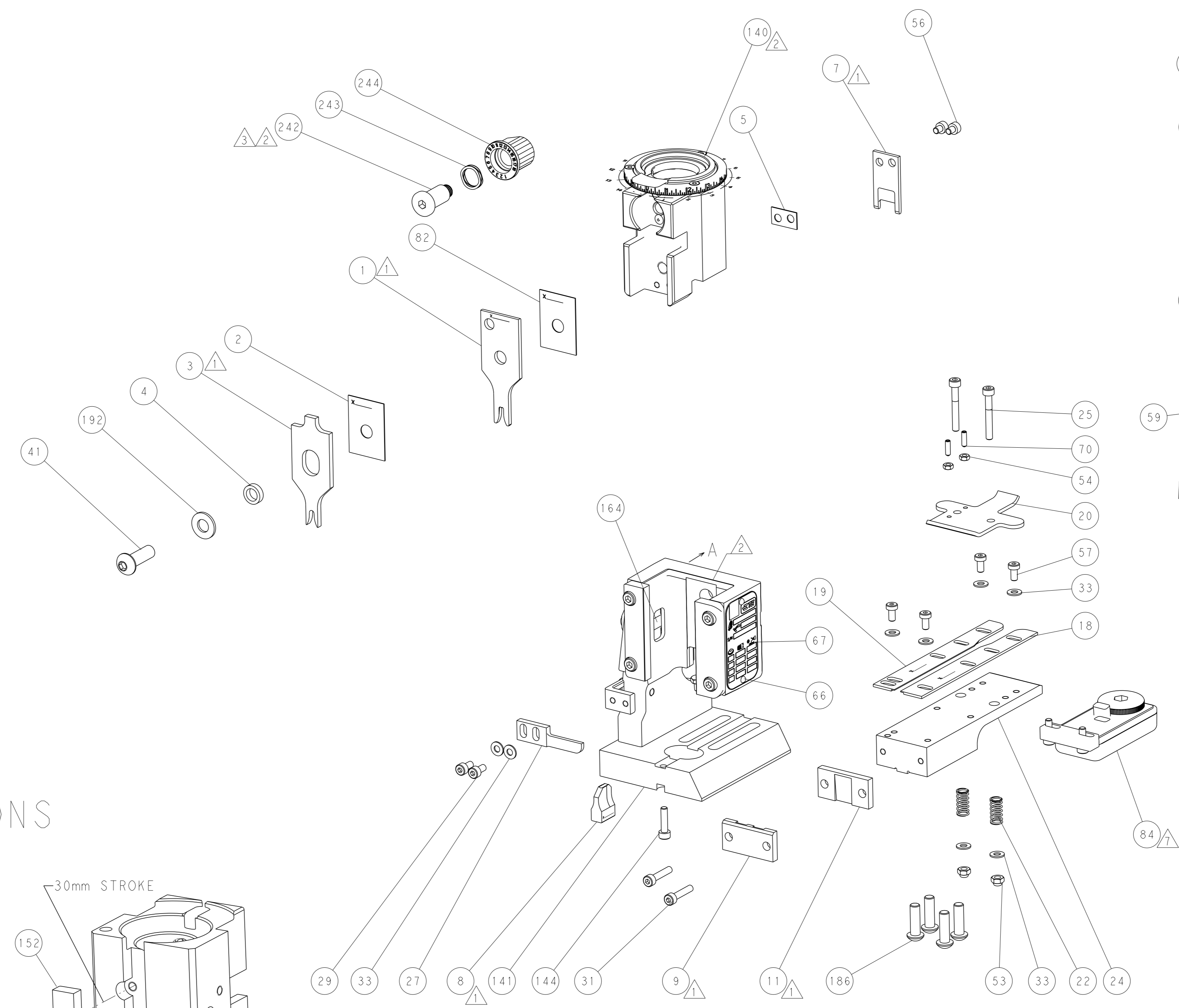
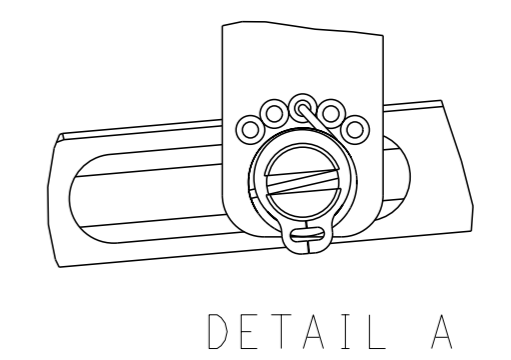

CAM POSITIONS

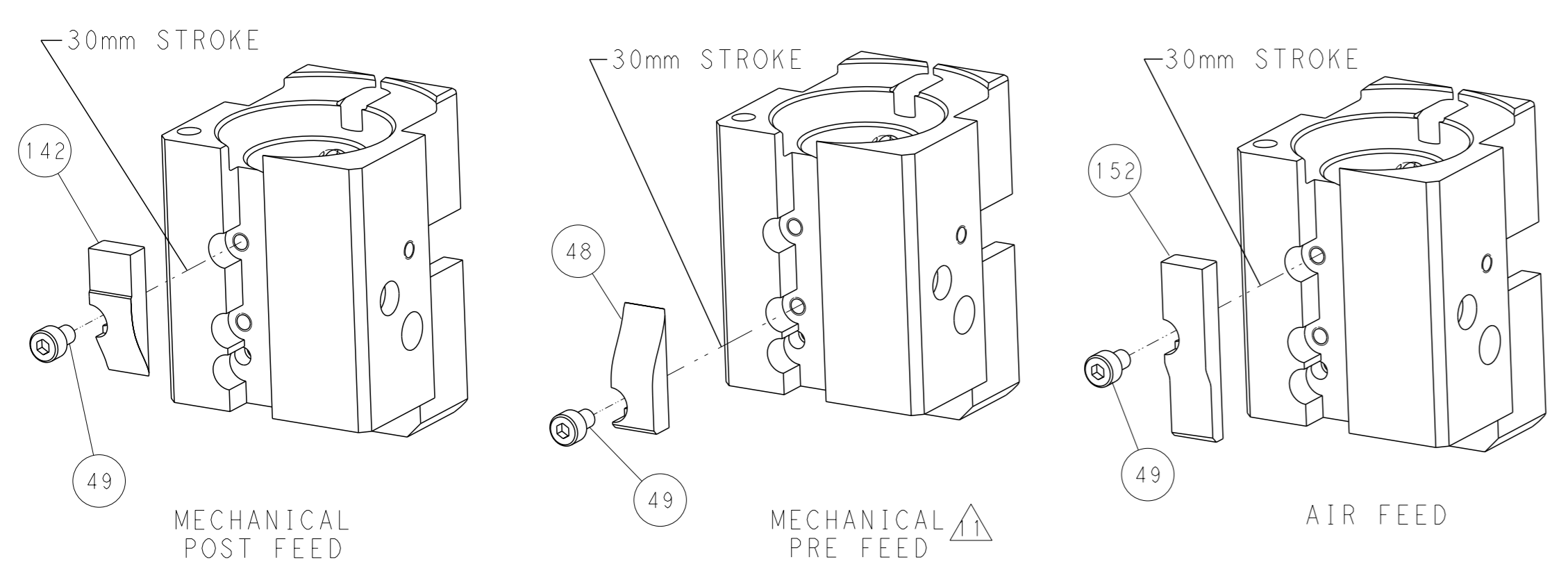

PACIFIC VERSION
 Shown on sheets 3 of 4 & 4 of 4
 (Atlantic version shown on sheets 1 of 4 & 2 of 4)

DIMENSIONS:		TOLERANCES UNLESS OTHERWISE SPECIFIED:		OWN: L. GROSS 14OCT2013		STE TE Connectivity	
mm		0 PLC ±		CAGE CODE: G. BAILEY 14OCT2013		Harrisburg, PA 17105-3608	
MATERIAL:		1 PLC ±		APVD: M. CLIFFORD 14OCT2013		NAME: Ocean End Feed Applicator	
		2 PLC ±		PRODUCT SPEC:		SIZE: A 00779	
		3 PLC ±		APPLICATION SPEC:		CAGE CODE: C=2150381	
		4 PLC ±		WEIGHT:		SCALE: 1:1 SHEET 4 OF 4 REV C	
		ANGLES FINISH *		Customer Accessible Production Drawing		RESTRICTED TO:	