

Verpackt in Gurtverpackung
Tape on Reel Packaging
 Verpackungseinheit: 280 Stück
Packaging unit: 280 pcs

Anforderungsstufe 1
Performance Level 1

Kontaktbereich vergoldet
Mating Area gold plating

Anschlussbereich verzinnt 4-6 µm
Terminal Area 4-6 µm tin plating

Koplanarität der Anschlüsse ≤ 0,1 mm
Coplanarity Area of Termination ≤ 0,1 mm

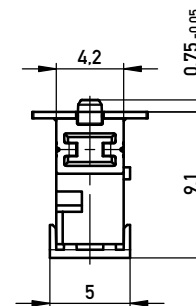
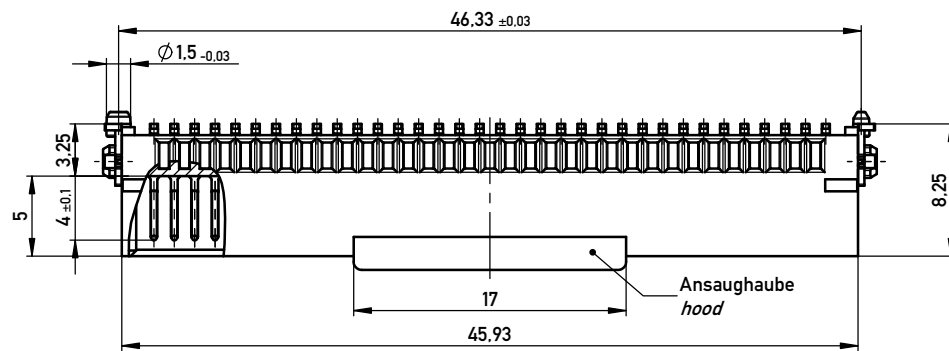
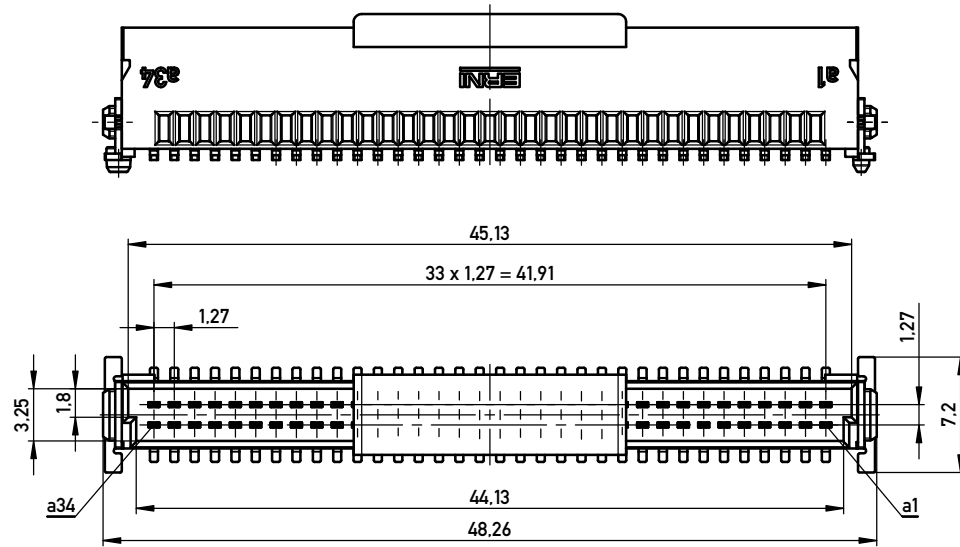
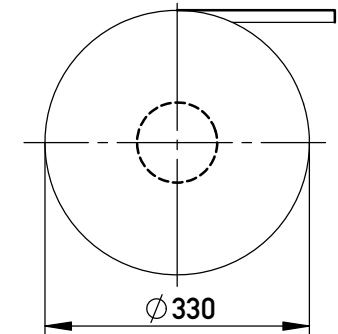

Abspulrichtung - Reel off Direction

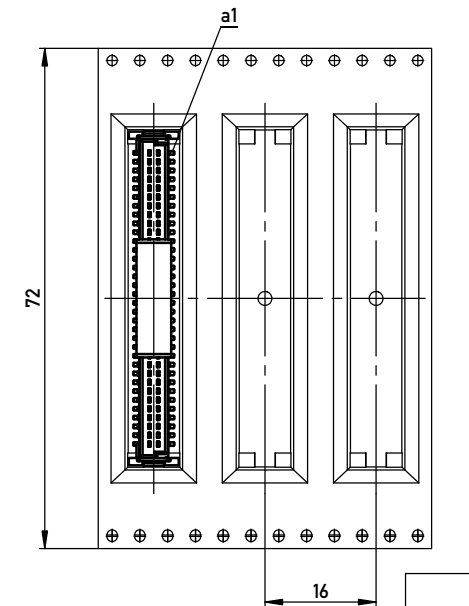

Leiterplatten-Layout Vorschlag für SMT
PCB-Layout Proposal for SMT

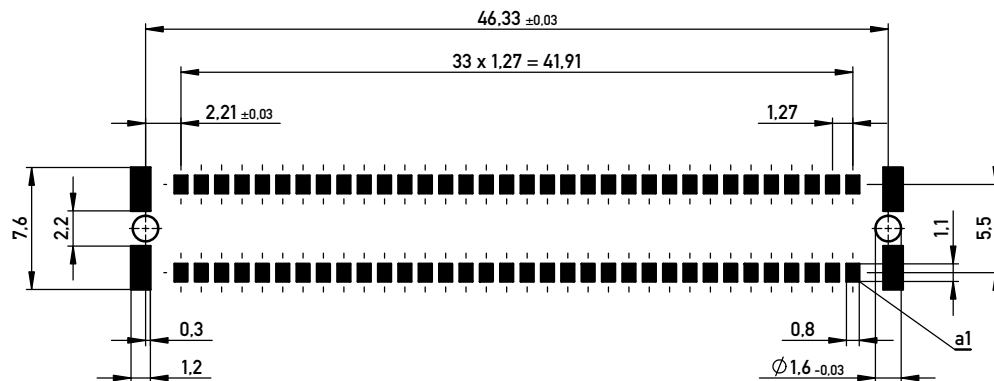

BA 8-03 - Standard Bauhöhe

type 8-03 - Standard Assembly Height

Information:	Tolerances	 All Dimensions in mm	Scale	3:1
	All rights reserved. Only for Information. To ensure that this is the latest version of this drawing, please contact one of the ERNI companies before using.		Designation Messrl. SMC-Q 68-SMD-BA8-03 <i>Male SMC-Q 68-SMD-type8-03</i>	
Subject to modification without prior notice. Drawing will not be updated.		 www.ERNI.com	244857	
d	08.07.2013		Class SMCQ	
Index	Date	I A3		

Copyright by ERNI GmbH. Proprietary notice pursuant to ISO 9006 to be observed.