

NOTES:

1. MATERIAL: .010/(0.25) THICK C51000 PHOSPHOR BRONZE, SPRING TEMPER
2. FINISH: TERMINAL PLATING OPTIONS PER ES-88-***.
*TIN .000050/(0.00125) MIN. OVERALL OVER .000050/(0.00125) MIN. NICKEL OVERALL.
*THE PRIMARY SHIPPING CARTON WILL BE LABELED "COMPLIANT TO ROHS DIRECTIVE 2002/95/EC AND ELV ANNEX II OF DIRECTIVE 2000/53/EC." CARTONS WITHOUT THIS LABEL MAY CONTAIN PRODUCT WITH TIN-LEAD.
3. PRODUCT SPECIFICATION: NA
4. PACKAGING INFORMATION: NA
5. TERMINALS ARE TO BE USED IN 1840 AND 3099 ASSEMBLIES AND WILL MATE WITH .093 SERIES PINS.

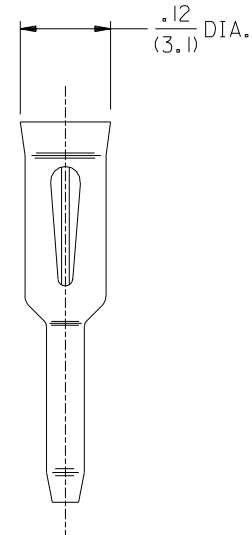
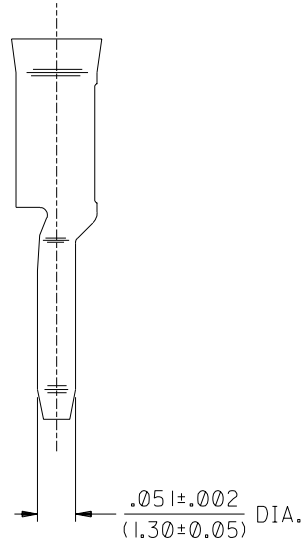
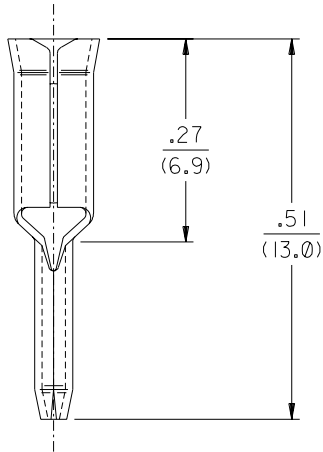
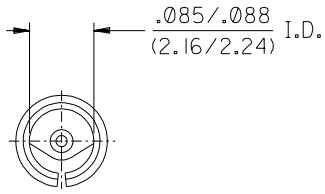

D	REVISED PER ECN # UCP2004-1988 4-13-04 FS
CI	REVISED PER ECN #U5 0147 9-26-94 RW
C	REVISED PER ECR #U5 0081 8-24-94 RW
B	CHANGES PER ECR U4 0487 CXC 4/19/94 RW
A	FINAL RELEASE ECN #U4 0165 2-2-94 RW
I	X-RELEASE ECR U3 1687 CXC 11/15/93 RW

MFG.	SH.	REV.	LTR.	REVISIONS
------	-----	------	------	-----------

DIMENSIONS SHOWN (METRIC) INCH		
UNLESS OTHERWISE SPECIFIED TOLERANCES: ANGULAR ± 1/2°		
	INCH	METRIC
3 PLACE	± .010	---
2 PLACE	± .014	± 0.25
1 PLACE	---	± 0.36
DRAFT WHERE APPLICABLE MUST REMAIN WITHIN DIMENSIONS		

▽ = 0 ▼ = 0 REVISE ONLY ON CAD SYSTEM

TITLE
SOCKET TERMINAL
P.C. TAIL FOR .093 SERIES
HEADERS

MOLEX INCORPORATED SHEET NO. DATE
LISLE, ILL. 60532 U.S.A. 1 OF 1 11/15/93

PART NO. DRWG. NO.
43080-0001 SD-43080-****

DRWG. BY: CXC
APP'D. BY: RAS

CHK'D. BY: RW
SCALE: 6 : 1

FILE NAME: S43080X1 DGN
THIS DRAWING CONTAINS INFORMATION THAT IS PROPRIETARY TO MOLEX INC. AND SHOULD NOT BE USED WITHOUT WRITTEN PERMISSION.
DIV. CP SIZE B