

PRODUCT DATA DRAWING

REVISION HISTORY			
REV	DESCRIPTION	DATE	APPROVED
-	DCN 47331	04/18	JMS

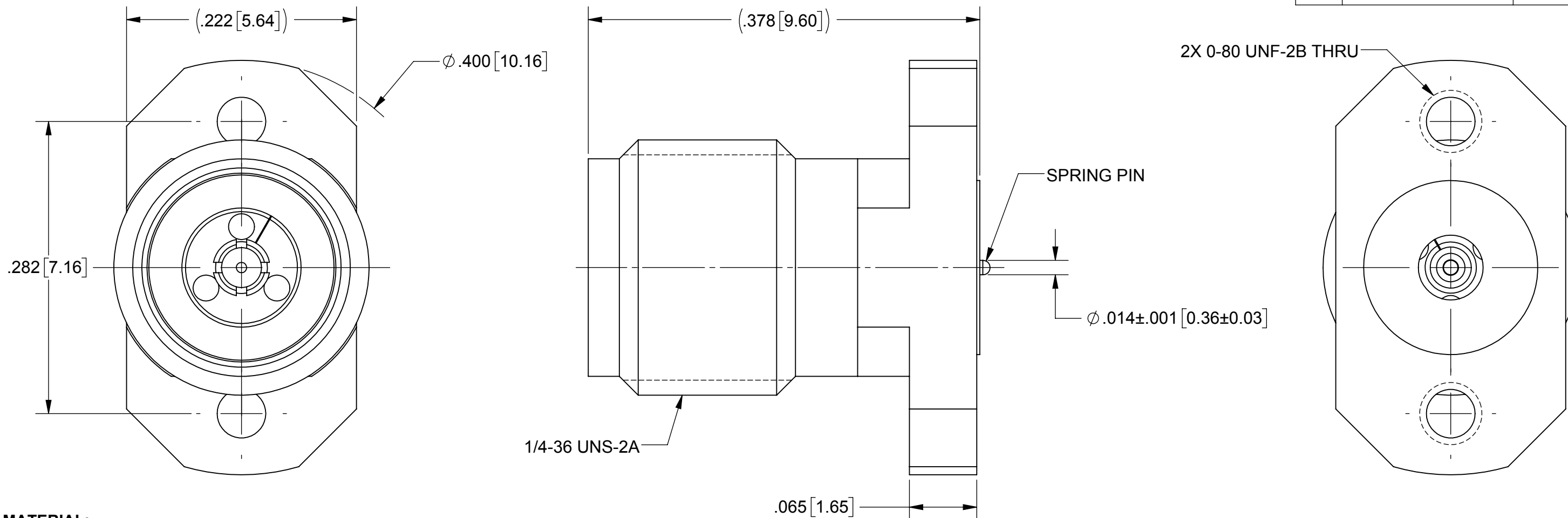

MATERIAL:

BODY & INSERT: STAINLESS STEEL PER AMS-5640, ALLOY UNS S30300, TYPE 1; OR ASTM A582 TYPE 303, COND. A

CONTACTS: BERYLLIUM COPPER PER ASTM B196, ALLOY No. UNS C17300, TD04

INSULATOR: ULTEM PER ASTM D5205

FINISH:
BODY & INSERT: PASSIVATED PER AMS-2700

CONTACTS: GOLD PER ASTM B488, TYPE II, CODE C, CLASS 1.27, OVER NICKEL PER AMS-QQ-N-290, CLASS 1, .00005" MIN.

PERFORMANCE:

IMPEDANCE: 50 OHMS
FREQ. RANGE: DC TO 40.0 GHz.
VSWR: 1.30:1 DC TO 40.0 GHz.
INSERTION LOSS: .05 X SQRT(F(F IN GHz.))
DWV: 500 VRMS

ENGAGEMENT/ DISENGAGEMENT: 2 IN-LBS.

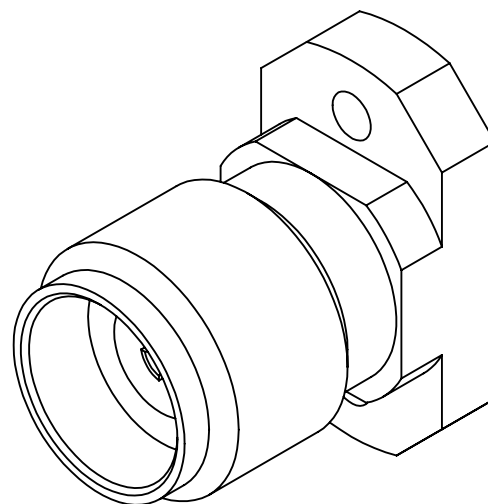

SV P/N	DESCRIPTION	PCB THICKNESS
SF1521-60124-1S	INCL. TWO .188 SCREWS	.028 TO .123

NOTES:
1. FOR A FOOTPRINT RECOMMENDATION SPECIFIC TO YOUR PCB, PLEASE CONTACT US AT applications@svmicro.com

MATERIAL: SEE NOTES	DIMENSIONS ARE IN INCHES TOLERANCES: FRACTIONAL: $\pm 1/64$ ANGULAR: X° $\pm 1'0''$ X°X' $\pm 15''$	UNLESS OTHERWISE SPECIFIED 1) ALL DIMENSIONS ARE IN INCHES (MILLIMETERS) 2) ALL DIMENSIONS ARE AFTER PLATING. 3) BREAK CORNERS & EDGES .005 R. MAX. 4) CHAM. 1ST & LAST THREADS. 5) SURFACE ROUGHNESS 63 MIL-STD-10. 6) DIA.'S ON COMMON CENTERS TO BE CONCENTRIC WITHIN .005 T.I.R. 7) REMOVE ALL BURRS	 Amphenol 2400 Centrepark West Drive, Suite 100 West Palm Beach, FL 33409 TITLE: 2.92mm FEMALE 2 HOLE FLANGE MOUNT W/ SPRING PIN
FINISH: SEE NOTES	DECIMAL: X $\pm .030$.XX $\pm .010$.XXX $\pm .005$	INTERPRET DIMENSIONS AND TOLERANCES PER ASME Y14.5M - 1994	
SURFACE AREA: N/A	THIRD ANGLE PROJECTION	DRAWN: VB 04/02/18	DWG. NO. SF1521-60124-1S SCALE: 10:1
PROPRIETARY THE INFORMATION CONTAINED IN THIS DRAWING IS THE SOLE PROPERTY OF SV MICROWAVE, INC. ANY REPRODUCTION IN PART OR AS A WHOLE WITHOUT THE WRITTEN PERMISSION OF SV MICROWAVE, INC IS PROHIBITED.	 DRAWN: VB 04/02/18 CHECKED: JMS 04/02/18 APPROVED: JMS 04/02/18	CAGE CODE B 95077 SHEET 1 OF 1	