

# PulseJack™

## 1X4 Tab-Up PoE and PoE+

### Description:

100/1000 Base-T 1x4 Tab-Up Low Profile Integrated Connector Module (ICM), with or without LEDs - Designed to support Router applications.



### Features and Benefits:

- Ⓢ RoHS peak wave solder temperature rating 260°C
- Ⓢ Suitable for CAT 5 & 6 Fast Ethernet Cable or better UTP
- Ⓢ Meets IEEE 802.3 specification
- Ⓢ 350µH minimum OCL with 8mA bias current
- Ⓢ High performance for maximum EMI suppression

### Electrical Specifications @ 25°C - Operating Temperature 0°C to +70°C

RoHS Compliant Part Number	Speed	PoE/PoE+	LEDs L/R	Insertion Loss TX/RX (dB TYP) 1-100 MHz	Return Loss (dB TYP) 100Ω (±15Ω)			Crosstalk (dB TYP)			Common Mode Rejection (dB TYP) 1-125 MHz	Hipot (Vrms MIN) @ 60Hz 1 MIN
					1-10 MHz	30 MHz	60-80 MHz	1-10 MHz	30-60 MHz	60-100 MHz		
J1N-0003NL	1000Base-T	PoE+	G/G	-1.0	-20	-18	-14	-45	-40	-35	-35	1500
J1N-0004NL	1000Base-T	PoE+	None	-1.0	-20	-18	-14	-45	-40	-35	-35	1500
J1N-0005NL	1000Base-T	None	G-0/G	-1.0	-20	-18	-14	-45	-40	-35	-35	1500
J1N-0006NL	1000Base-T	None	None	-1.0	-20	-18	-14	-45	-40	-35	-35	1500
J1N-0007NL	1000Base-T	PoE	None	-1.0	-20	-18	-14	-45	-40	-35	-35	1500
J1N-0008NL	1000Base-T	PoE	G/G	-1.0	-20	-18	-14	-45	-40	-35	-35	1500
J1N-0011NL	100Base-TX	PoE	None	-1.0	-20	-18	-14	-45	-40	-35	-35	1500
J1N-0012NL	100Base-TX	None	None	-1.0	-20	-18	-14	-45	-40	-35	-35	1500
J1N-0013NL	100Base-TX	None	G/Y	-1.0	-20	-18	-14	-45	-40	-35	-35	1500

### Notes:

1. LEDs Left/Right: **G** = Green, **O** = Orange **Y** = Yellow

### RJ45 Durability Testing Rating

Part Number	Mating Force (MAX)	Ultimate Force (MAX)	Durability	Plug to Jack Retention (MIN)
J1N Series	5 lbs./2.268 kgs.	5 lbs./2.268 kgs.	750 Insertions	20 lbs./9.072 kgs.

### RJ45 Material Specification

Part Number	Shield		Contact			Housing		
	Material	Finish	Material	Plating Area	Solder Area	Material	Specification	MSL <sup>2</sup>
J1N Series	Brass	20-40µ inches thick Nickel over Brass	Phosphor Bronze	30µ inches gold over 30-80µ inches nickel	Tin matte finish	Thermoplastic	UL 94 V-0	1

### Notes:

1. Connector dimensions comply with FCC part 68 dimension requirements.

2. MSL = Moisture Sensitivity Level rating from 1 to 5 (highest rating = 1, lowest rating = 5).

# PulseJack™

## 1X4 Tab-Up PoE and PoE+

### Mechanicals

J1N-0003NL, J1N-0008NL

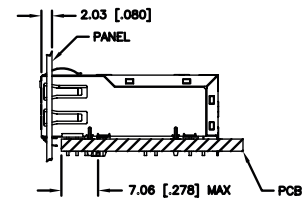
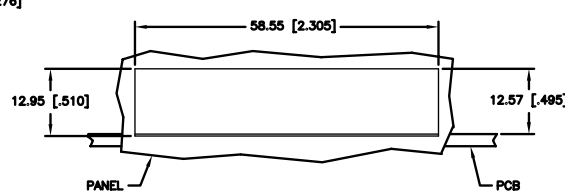
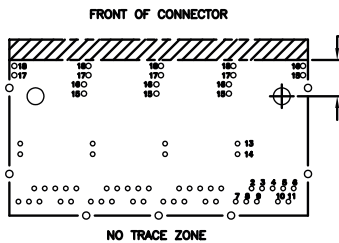
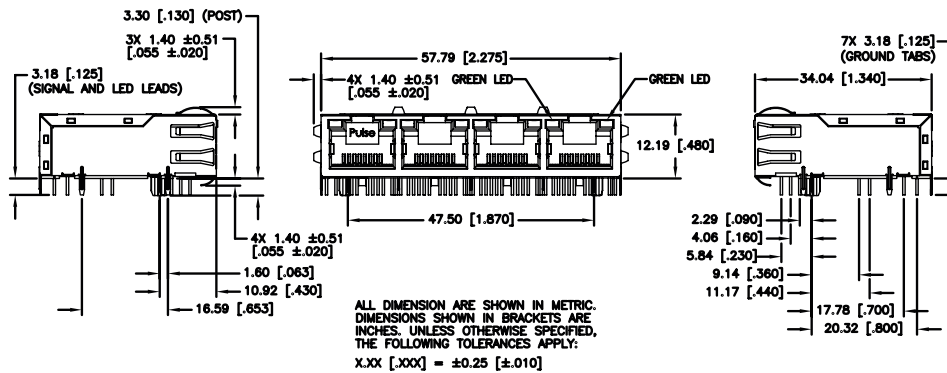
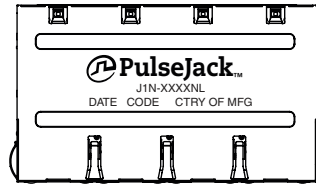

SUGGESTED PANEL CUTOUT

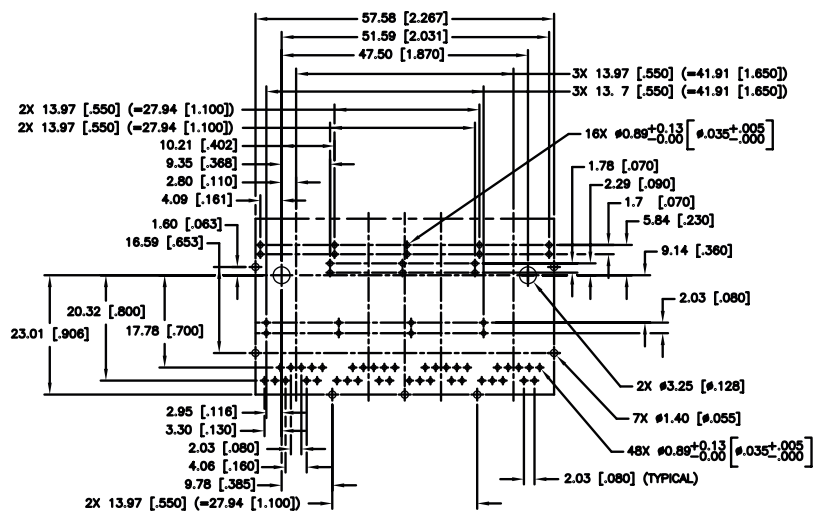

ALL DIMENSION ARE SHOWN IN METRIC. DIMENSIONS SHOWN IN BRACKETS ARE INCHES. UNLESS OTHERWISE SPECIFIED, THE FOLLOWING TOLERANCES APPLY:  
 X.XX [.XXX] = ±0.08 [±.003]

SUGGESTED FOOTPRINT (COMPONENT SIDE SHOWN)

# PulseJack™

## 1X4 Tab-Up PoE and PoE+

### Mechanicals (continued)

J1N-0004NL, J1N-0007NL

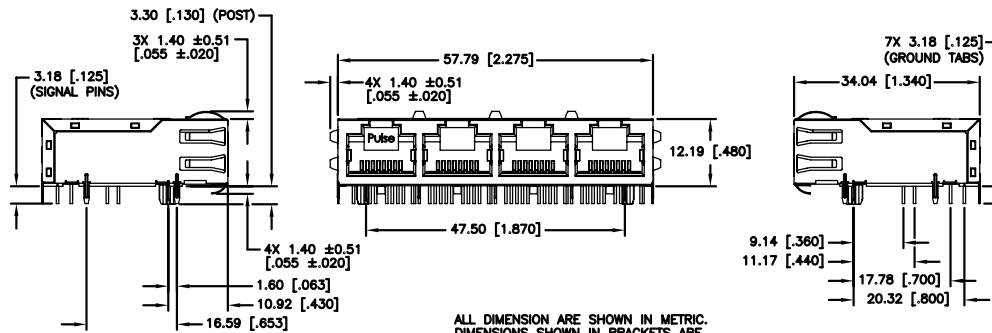
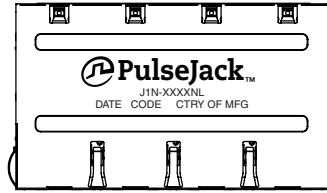

ALL DIMENSION ARE SHOWN IN METRIC. DIMENSIONS SHOWN IN BRACKETS ARE INCHES. UNLESS OTHERWISE SPECIFIED, THE FOLLOWING TOLERANCES APPLY:  
 X.XX [.XXX] = ±0.25 [±.010]

FRONT OF CONNECTOR

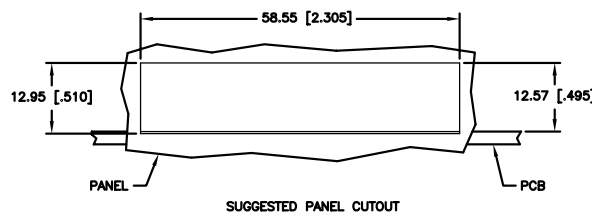
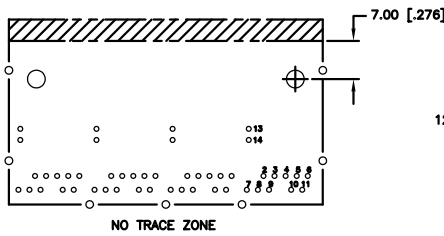

SUGGESTED PANEL CUTOUT

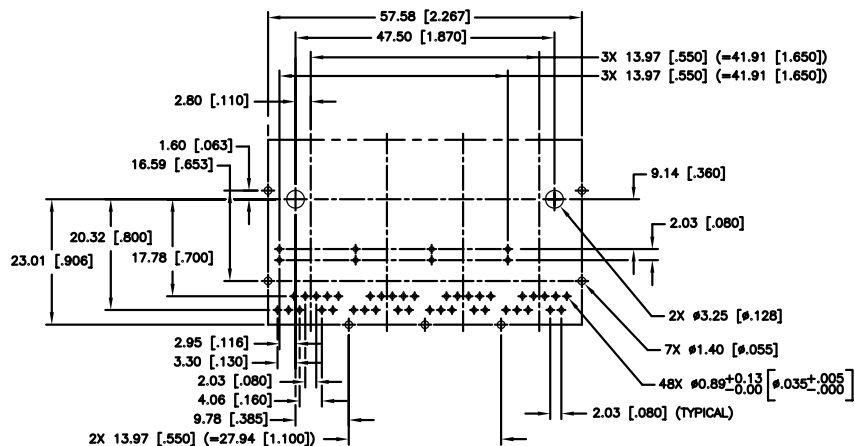
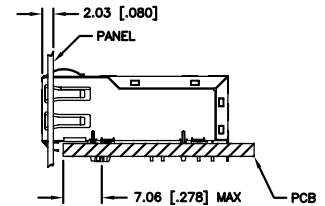

ALL DIMENSION ARE SHOWN IN METRIC. DIMENSIONS SHOWN IN BRACKETS ARE INCHES. UNLESS OTHERWISE SPECIFIED, THE FOLLOWING TOLERANCES APPLY:  
 X.XX [.XXX] = ±0.08 [±.003]

SUGGESTED FOOTPRINT (COMPONENT SIDE SHOWN)

# PulseJack™

## 1X4 Tab-Up PoE and PoE+

### Mechanicals (continued)

J1N-0005NL, J1N-0006NL

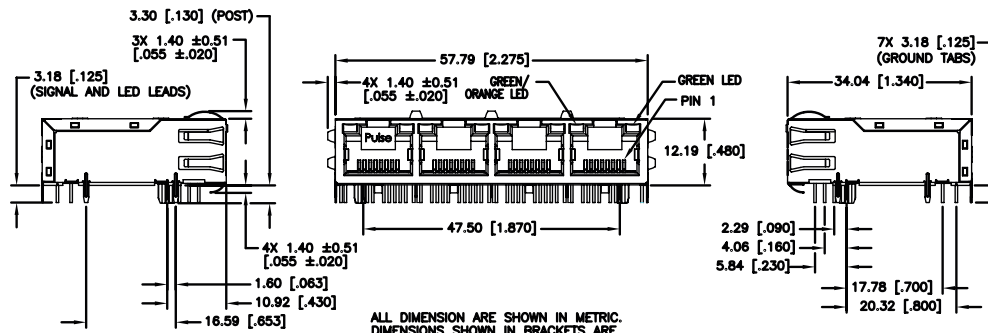
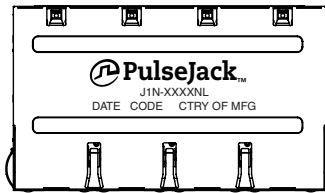

ALL DIMENSION ARE SHOWN IN METRIC. DIMENSIONS SHOWN IN BRACKETS ARE INCHES. UNLESS OTHERWISE SPECIFIED, THE FOLLOWING TOLERANCES APPLY:  
 X.XX [XXX] = ±0.25 [±0.010]

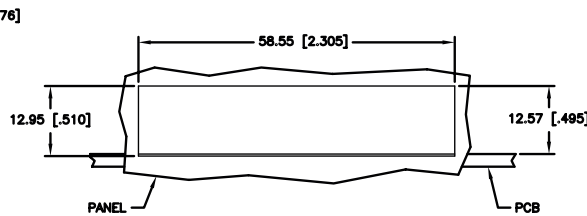
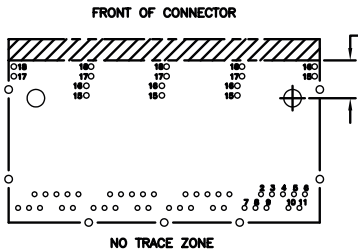

SUGGESTED PANEL CUTOUT

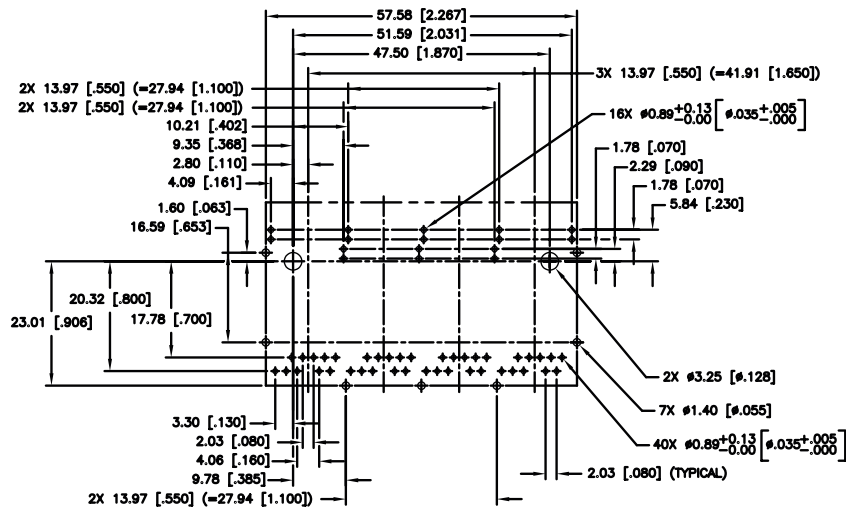
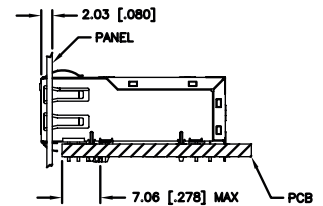

ALL DIMENSION ARE SHOWN IN METRIC. DIMENSIONS SHOWN IN BRACKETS ARE INCHES. UNLESS OTHERWISE SPECIFIED, THE FOLLOWING TOLERANCES APPLY:  
 X.XX [XXX] = ±0.08 [±0.003]

SUGGESTED FOOTPRINT (COMPONENT SIDE SHOWN)

**Note: No LED's pinout for J1N-0006NL**

# PulseJack™

## 1X4 Tab-Up PoE and PoE+

### Mechanicals (continued)

J1N-0011NL, J1N-0012NL, J1N-0013NL

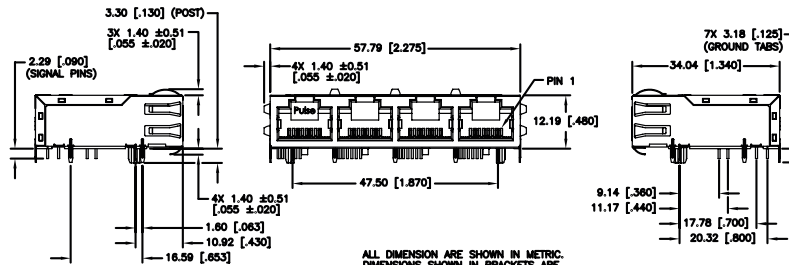
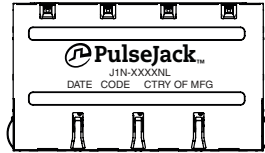

ALL DIMENSION ARE SHOWN IN METRIC. DIMENSIONS SHOWN IN BRACKETS ARE INCHES. UNLESS OTHERWISE SPECIFIED, THE FOLLOWING TOLERANCES APPLY:  
X.XX [.XXX] = ±0.25 [±.010]

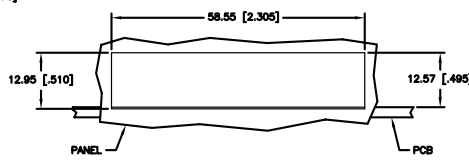
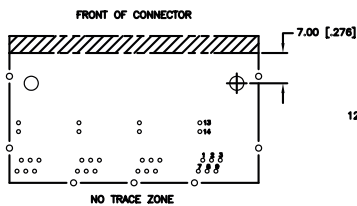

SUGGESTED PANEL CUTOUT

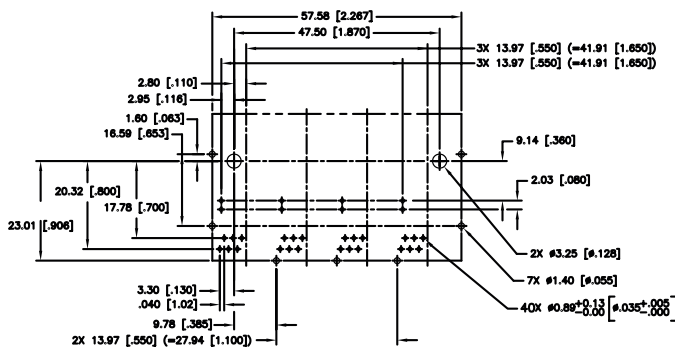
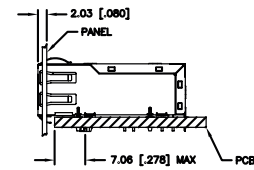

ALL DIMENSION ARE SHOWN IN METRIC. DIMENSIONS SHOWN IN BRACKETS ARE INCHES. UNLESS OTHERWISE SPECIFIED, THE FOLLOWING TOLERANCES APPLY:  
X.XX [.XXX] = ±0.08 [±.003]

SUGGESTED FOOTPRINT (COMPONENT SIDE SHOWN)

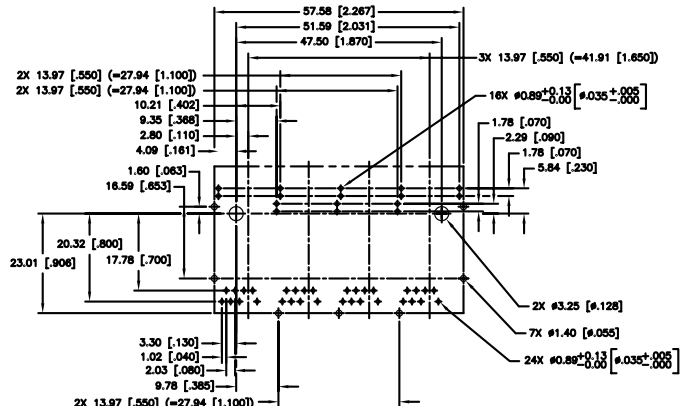

ALL DIMENSION ARE SHOWN IN METRIC. DIMENSIONS SHOWN IN BRACKETS ARE INCHES. UNLESS OTHERWISE SPECIFIED, THE FOLLOWING TOLERANCES APPLY:  
X.XX [.XXX] = ±0.08 [±.003]

SUGGESTED FOOTPRINT (J1N-0013NL SIDE SHOW)

Note: No PoE pinout for J1N-0012NL

# PulseJack™

## 1X4 Tab-Up PoE and PoE+

### Schematics

J1N-0003NL, J1N-0004NL, J1N-0007NL, J1N-0008NL

J1N-0005NL, J1N-0006NL,

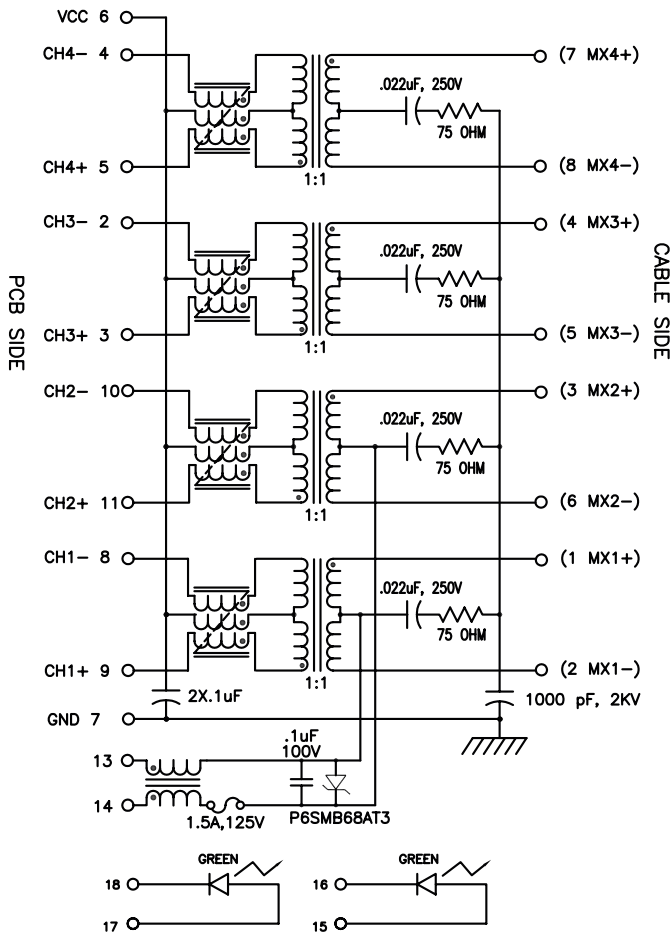

SCHEMATIC (EACH PORT)

EMMITTED COLOR	GREEN
WAVELENGTH (nm)	565
POWER DISSIPATION (Pd)	105 mW MAX
AVERAGEDDC FORWARD CURRENT	25 mA
FORWARD VOLTAGE (VF) @20mA	2.2 V TYP

NOTE: PER VENDOR'S SPECIFICATION

LED SPECIFICATIONS FOR J1N-0003NL AND J1N-0008NL

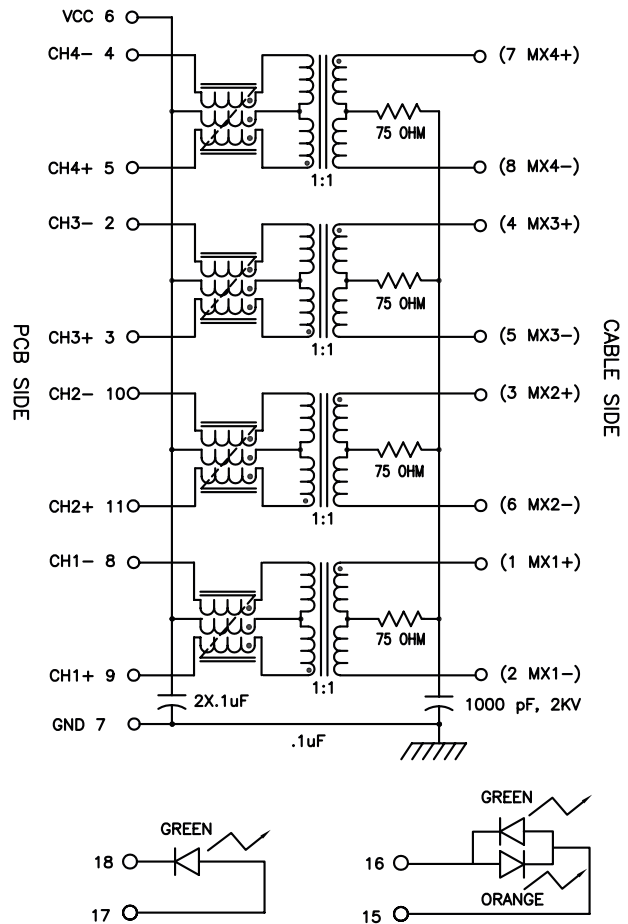

SCHEMATIC (EACH PORT)

EMMITTED COLOR	GREEN	ORANGE	GREEN
WAVELENGTH (nm)	565	607	565
POWER DISSIPATION (Pd)	105 mW MAX	105 mW MAX	100 mW MAX
AVERAGEDDC FORWARD CURRENT	25 mA	30 mA	30 mA
FORWARD VOLTAGE (VF) @20mA	2.2 V TYP	2.0 V TYP	2.2 V TYP

NOTE: PER VENDOR'S SPECIFICATION

LED SPECIFICATIONS FOR J1N-0005NL

# PulseJack™

## 1X4 Tab-Up PoE and PoE+

### Schematics (continued)

J1N-0011NL, J1N-0012NL

J1N-0013NL

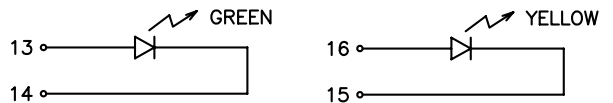
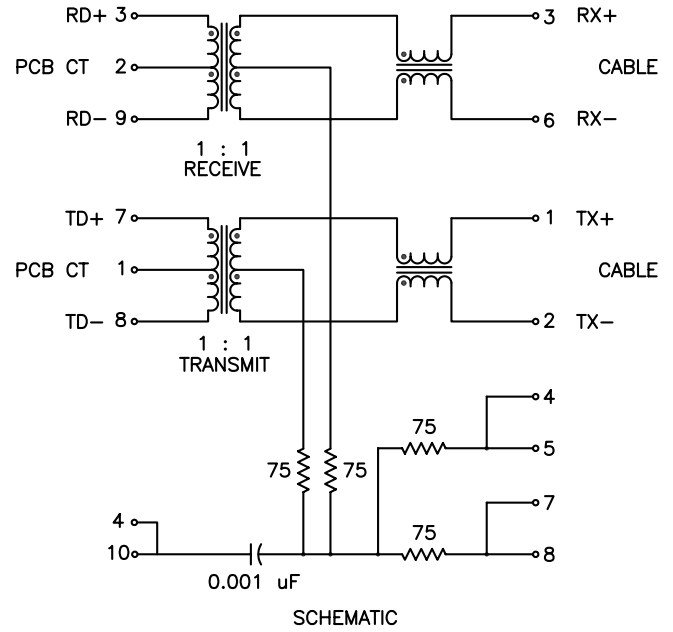
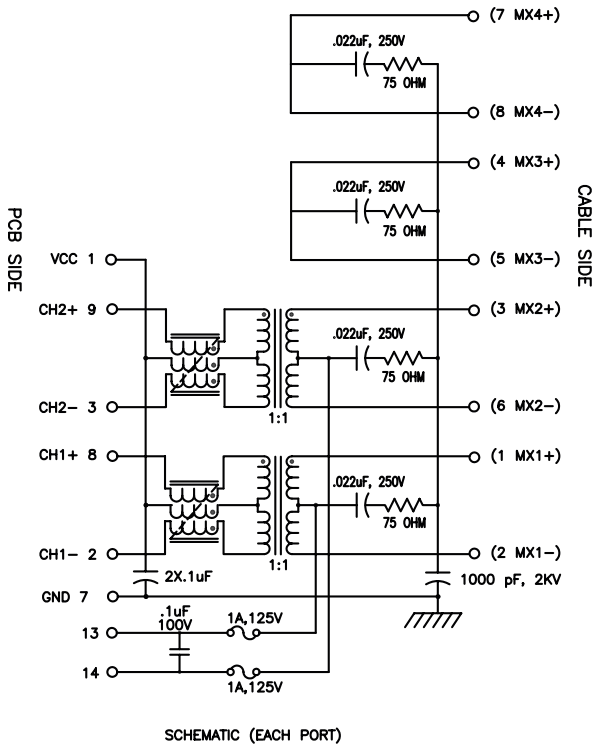

EMMITTED COLOR	GREEN	YELLOW
WAVELENGTH (nm)	565	565
POWER DISSIPATION (Pd)	105 mW MAX	105 mW MAX
AVERAGED DC FORWARD CURRENT	25 mA	25 mA
FORWARD VOLTAGE (VF) @20mA	2.2 V TYP	2.2 V TYP

NOTE: PER VENDOR'S SPECIFICATION

LED SPECIFICATIONS FOR J1N-0013NL

### For More Information:

Americas - [prodinfo@networkamericas@pulseelectronics.com](mailto:prodinfo@networkamericas@pulseelectronics.com) | Europe - [comms-Apps-Europe@pulseelectronics.com](mailto:comms-Apps-Europe@pulseelectronics.com) | Asia - [prodinfo@networkapac@pulseelectronics.com](mailto:prodinfo@networkapac@pulseelectronics.com)

Performance warranty of products offered on this data sheet is limited to the parameters specified. Data is subject to change without notice. Other brand and product names mentioned herein may be trademarks or registered trademarks of their respective owners. © Copyright, 2019. Pulse Electronics, Inc. All rights reserved.