

MCCOG128064D6W-FPTLW	128 x 64	N/A	LCD Module
<b>Specification</b>			
Version: 1		Date: 30/10/2020	
<b>Revision</b>			
1	27/10/2020	First Issue	

Display Features			
Resolution	128 x 64		
Appearance	Black on White		
Logic Voltage	3V		
Interface	Parallel / SPI		
Font Set	N/A		
Display Mode	Transflective		
LC Type	FSTN		
Module Size	45.00 x 40.00 x 10.40mm		
Operating Temperature	-20°C ~ +70°C		
Construction	COG	Box Quantity	Weight / Display
LED Backlight	White	---	---

design • manufacture • supply

\*- For full design functionality, please use this specification in conjunction with the ST7565R specification. (Provided Separately)

Display Accessories	
Part Number	Description

Optional Variants	
Appearances	Voltage



## 1. FUNCTIONS & FEATURES

- MCOG128064D6W-FPTLW Series LCD Type :
- Viewing Direction : 6 O'clock
- Driving Scheme : 1/65 Duty Cycle, 1/9 Bias
- Power Supply Voltage(Typ.) : 3.0 V
- LCD Operation Voltage :9.0 V
- Display Contents :128x64 Dots
- Backlight : LED,Lightguide,White
- Operating temperature : -20°C ~ +70°C
- Storage temperature : -30°C ~ +80°C
- RoHS Compliant

## 2. MECHANICAL SPECIFICATIONS

- Module Size: : 45.0(L) x 40.00(W) x 10.4(T)mm (without FPC)
- Viewing Area Size: : 37.00(W) x 28.00(H) mm
- Active Area Size : 36.08(W) x 23.02(H)mm
- Dot pitch: : 0.282(W) x 0.36(H)mm
- Dot Size: : 0.262(W) x 0.34(H) mm



# EXTERNAL DIMENSIONS

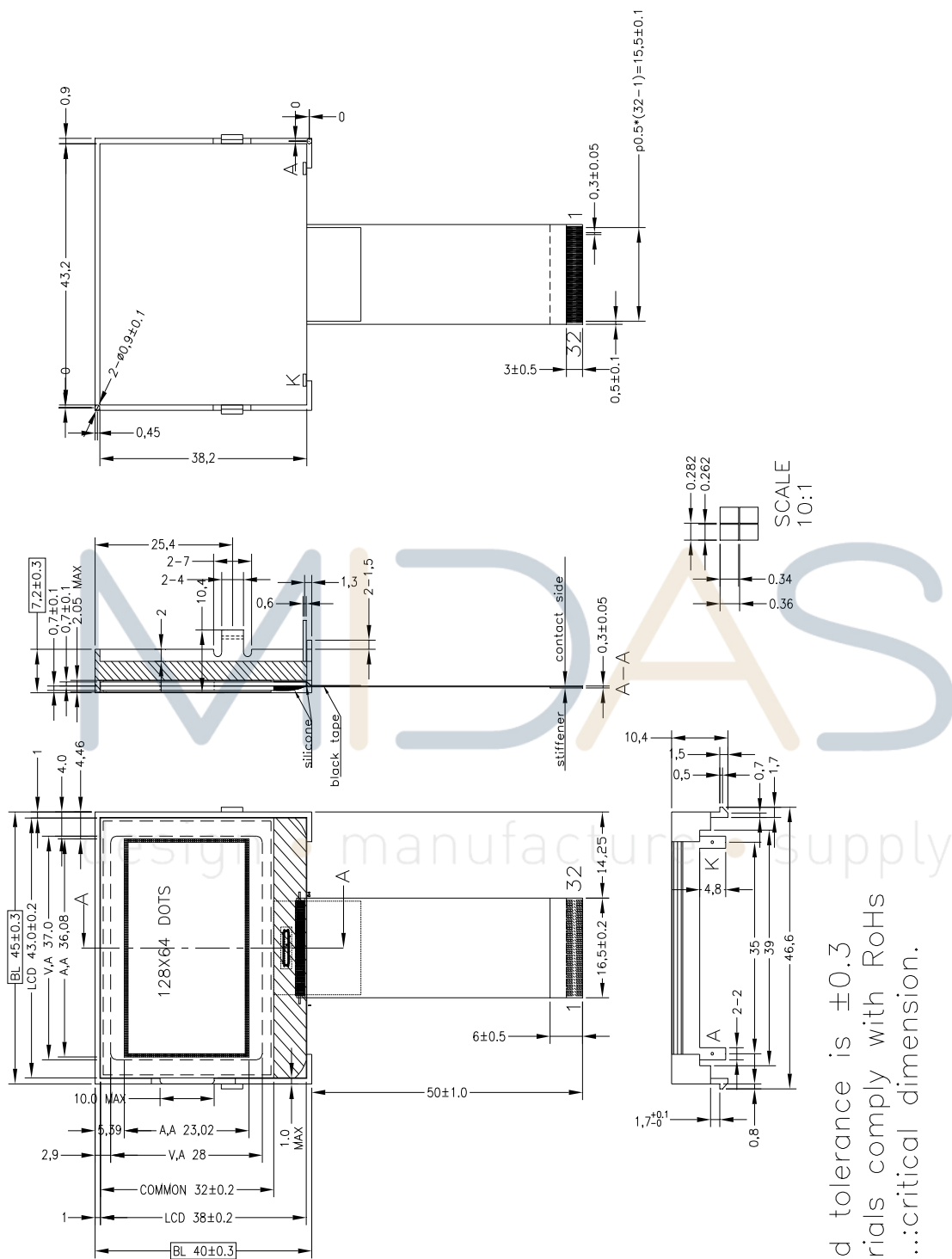

- Remarks:
1. Unmarked tolerance is  $\pm 0.3$
  2. All materials comply with RoHS
  3.  ...:critical dimension.

# BLOCK DIAGRAM

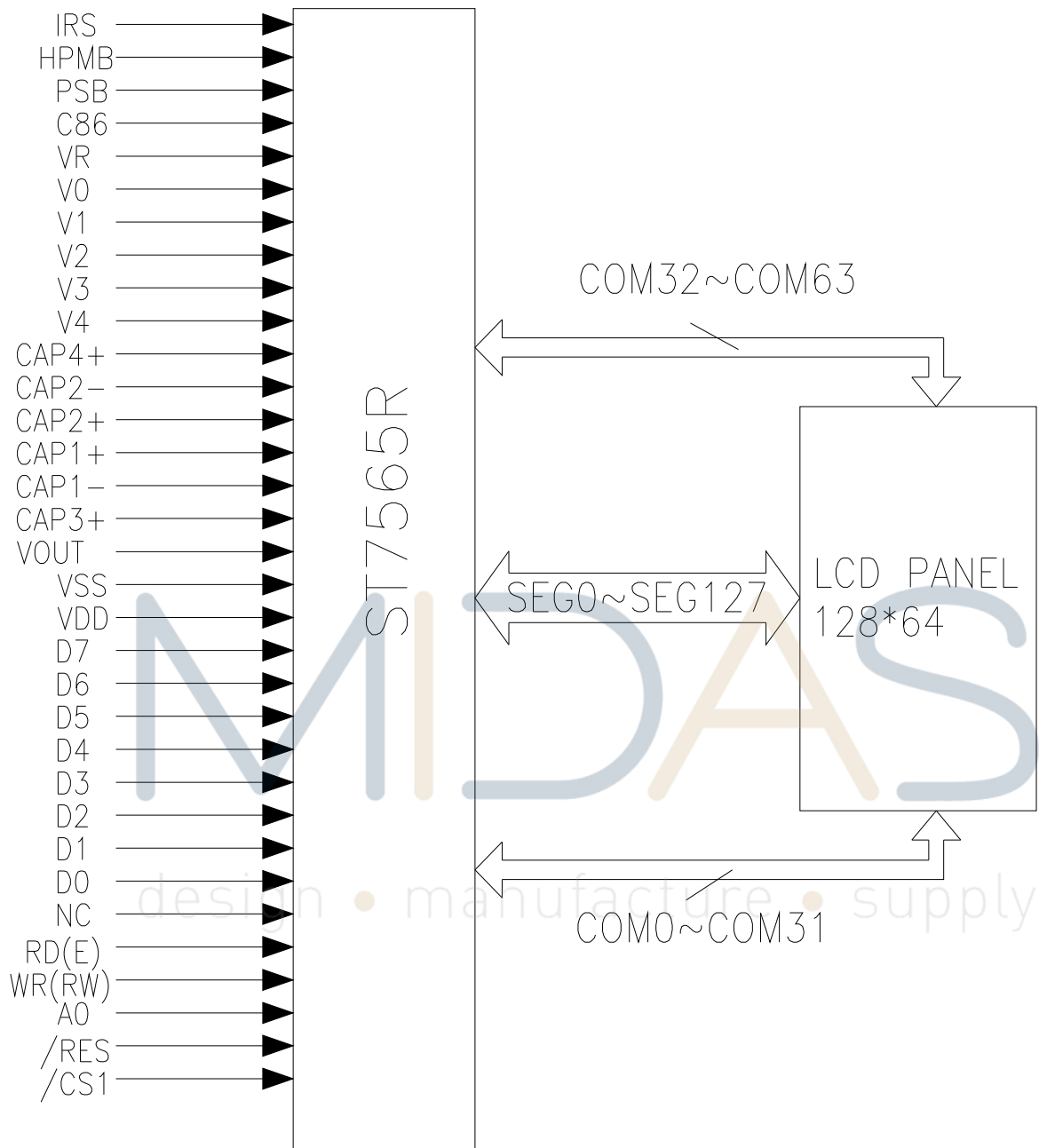

## PIN DESCRIPTION

Pin No.	Name	Description
1	IRS	This terminal selects the resistors for the V0 voltage level adjustment. IRS = "H": Use the internal resistors IRS = "L": Do not use the internal resistors. The V0 voltage level is regulated by an external resistive voltage divider attached to the VR terminal
2	HPMB	This is the power control terminal for the power supply circuit for liquid crystal drive. /HPM = "H": Normal mode /HPM = "L": High power mode (suggested)
3	PSB	This pin configures the interface to be parallel mode or serial mode. P/S = "H": Parallel data input/output. P/S = "L": Serial data input.
4	C86	This is the MPU interface selection pin. C86 = "H": 6800 Series MPU interface. C86 = "L": 8080 Series MPU interface.
5	VR	This is the internal-output VREG power supply for the LCD power supply voltage regulator.
6	V0	LCD driver supplies voltages
7	V1	
8	V2	
9	V3	
10	V4	
11	CAP4+	
12	CAP2-	
13	CAP2+	
14	CAP1+	
15	CAP1-	
16	CAP3+	
17	VOU	
17	VOU	design • manufacture • supply
18	VSS	Ground
19	VDD	Voltage supply
20	D7	This is an 8-bit bi-directional data bus that connects to an 8-bit or 16-bit standard MPU data bus. When the serial interface (SPI-4) is selected (P/S = "L") : D7 : serial data input (SI) ; D6 : the serial clock input (SCL). D0 to D5 should be connected to VDD or floating. When the chip select is not active, D0 to D7 are set to high impedance.
21	D6	
22	D5	
23	D4	
24	D3	
25	D2	
26	D1	
27	D0	
28	RD(E)	
29	WR(RW)	<ul style="list-style-type: none"> <li>When connected to 8080 series MPU, this pin is treated as the "/WR" signal of the 8080 MPU and is LOW-active.</li> <li>The signals on the data bus are latched at the rising edge of the /WR signal.</li> <li>When connected to 6800 series MPU, this pin is treated as the "R/W" signal of the 6800 MPU and decides the access type : When R/W = "H": Read. When R/W = "L": Write.</li> </ul>

30	A0	This is connect to the least significant bit of the normal MPU address bus, and it determines whether the data bits are data or command. A0 = "H": Indicates that D0 to D7 are display data. A0 = "L": Indicates that D0 to D7 are control data.
31	/RES	This is the chip select signal.
32	/CS1	The RESET signal

A	Supply voltage for backlight LED+
K	Supply voltage for backlight LED-

## BACKLIGHT CHARACTERISTICS

Item	Symbol	min.	typ.	max.	Unit	Condition
Forward Voltagt	Vf	2.9	3.1	3.3	V	If= 60 mA T=25° C
Power Dissipation	Pd	174	186	198	mW	
Luminous Uniformity	$\Delta L_v$	70			%	
Luminance	Lv	420	500		cd/m <sup>2</sup>	
Color Coordinate	X	0.260		0.30		
	Y	0.270		0.31		
Lifetime		50000h			Hours	

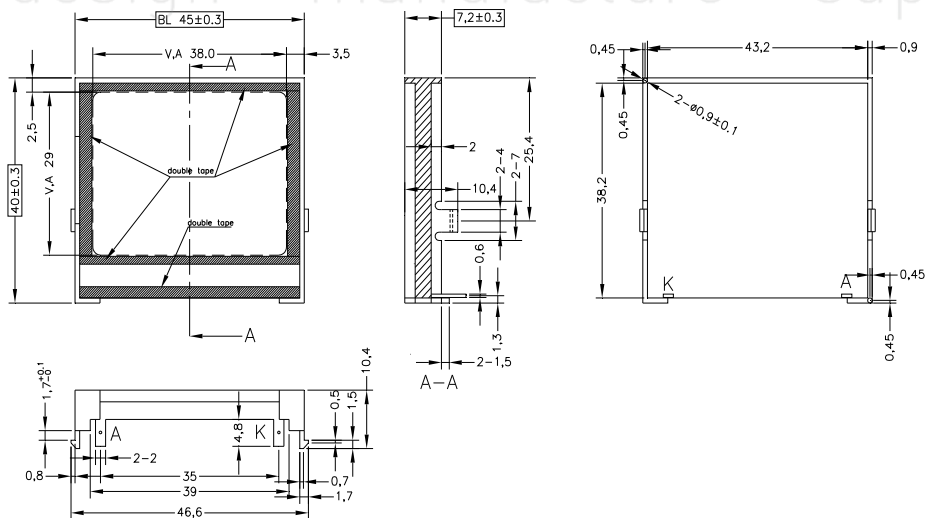

### Circuit Diagram COLOR:WHITE

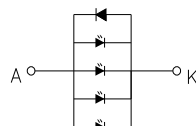

Remarks:  
1.Unmarked tolerance is ±0.3  
2.All materials comply with RoHs  
3.  ...critical dimension.

## ABSOLUTE MAXIMUM RATINGS

Parameter	Symbol	Conditions	Unit
Power Supply Voltage	VDD	-0.3 ~ 3.6	V
Power supply voltage (VDD standard)	V0, VOUT	-0.3 ~ 13.5	V
Power supply voltage (VDD standard)	V1, V2, V3, V4	-0.3 to V0	V
Operating temperature	TOPR	-20 to +70	°C
Storage temperature	TSTR	-30 to +80	°C

## ELECTRICAL CHARACTERISTICS

### 1. DC CHARACTERISTICS

Item	Symbol	Condition	STANDARD VALUE			units
			Min.	Typ.	Max.	
Operating Voltage	V <sub>DD</sub>	Relative to VSS	2.7	3.0	3.3	V
LCD driving voltage	V <sub>LCD</sub>	Relative to VSS	8.7	9.0	9.3	
High-level Input Voltage	V <sub>IHC</sub>	---	0.8 x VDD	---	VDD	
Low-level Input Voltage	V <sub>ILC</sub>	---	VSS	---	0.2 x VDD	
High-level Output Voltage	V <sub>OHC</sub>	IOH = -0.5 mA	0.8 x VDD	---	VDD	
Low-level Output Voltage	V <sub>OLC</sub>	IOH = -0.5 mA	VSS	---	0.2 x VDD	
Consumption current	I <sub>DD</sub>	---	---	TBD	---	mA

design • manufacture • supply



## 2. AC CHARACTERISTICS

System Bus Read/Write Characteristics 1 (For the 8080 Series MPU)

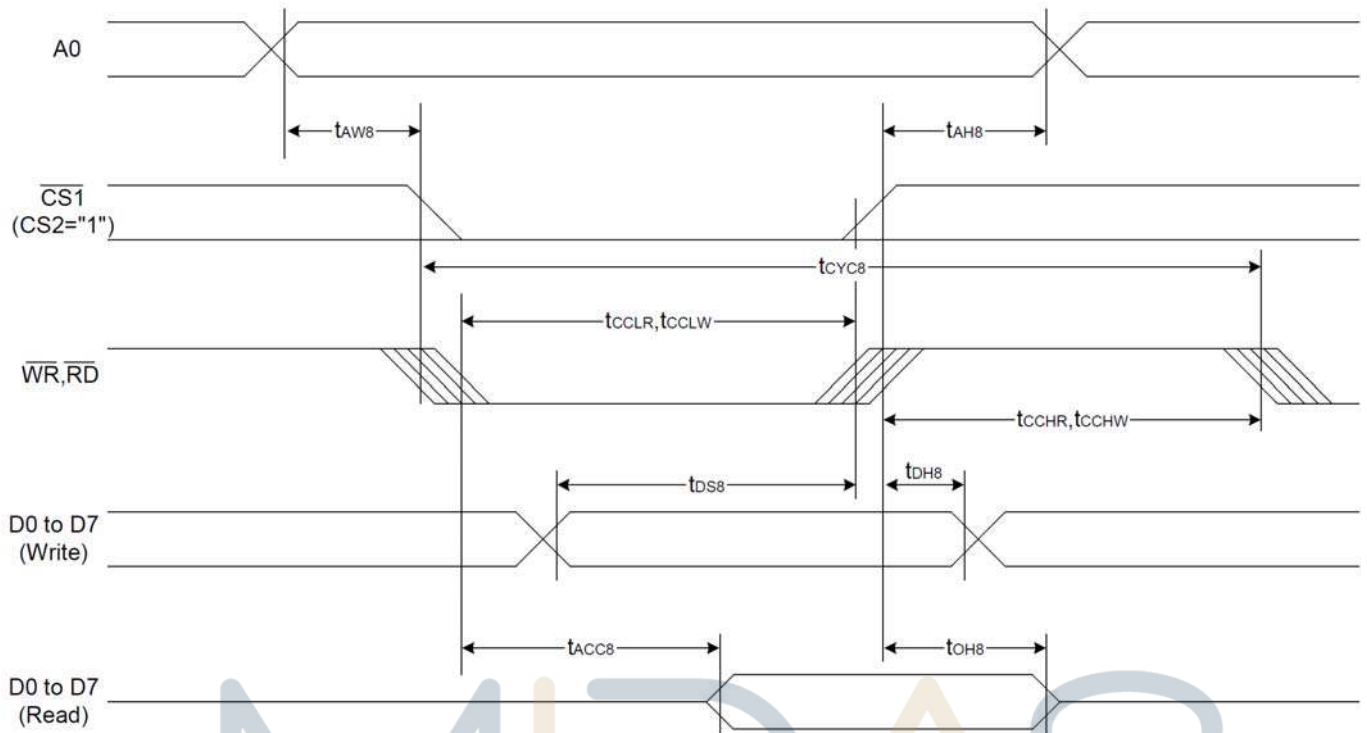

Item	Signal	Symbol	Condition	Rating		Units
				Min.	Max.	
Address hold time	A0	tAH8		0	—	Ns
Address setup time		tAW8		0	—	
System cycle time		tCYC8		240	—	
Enable L pulse width (WRITE)	WR	tCCLW		80	—	
Enable H pulse width (WRITE)		tCCHW		80	—	
Enable L pulse width (READ)	RD	tCCLR		140	—	
Enable H pulse width (READ)		tCCHR		80	—	
WRITE Data setup time	D0 to D7	tDS8		40	—	
WRITE Address hold time		tDH8		0	—	
READ access time		tACC8	CL = 100 pF	—	70	
READ Output disable time		tOH8	CL = 100 pF	5	50	



### System Bus Read/Write Characteristics 2 (For the 6800 Series MPU)

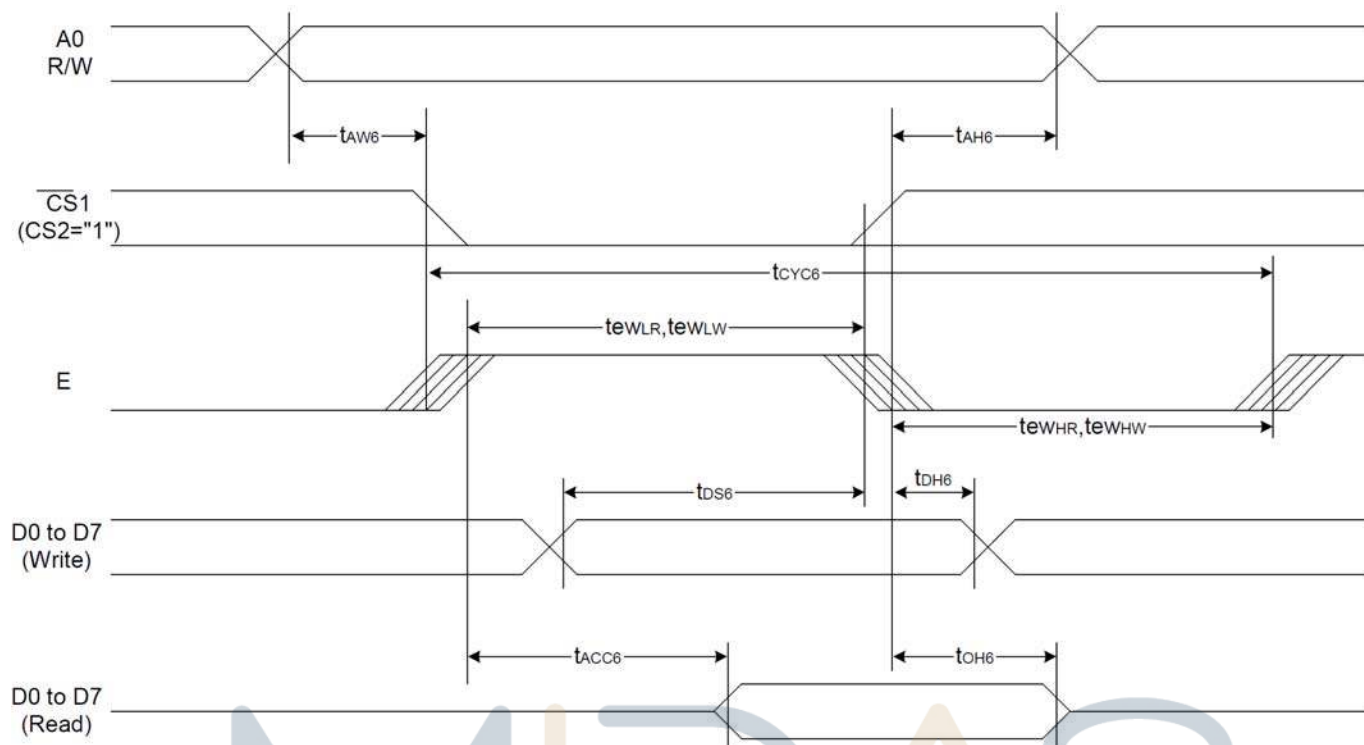

Item	Signal	Symbol	Condition	Rating		Units
				Min.	Max.	
Address hold time	A0	tAH6		0	—	ns
Address setup time		tAW6		0	—	
System cycle time		tCYC6		240	—	
Enable L pulse width (WRITE)	WR	teWLW		80	—	
Enable H pulse width (WRITE)		teWHW		80	—	
Enable L pulse width (READ)	RD	teWLR		80	—	
Enable H pulse width (READ)		teWHR		140	—	
WRITE Data setup time	D0 to D7	tDS6		40	—	
WRITE Address hold time		tDH6		0	—	
READ access time		tACC6	CL = 100 pF	—	70	
READ Output disable time		tOH6	CL = 100 pF	5	50	



### The 4-line SPI Interface

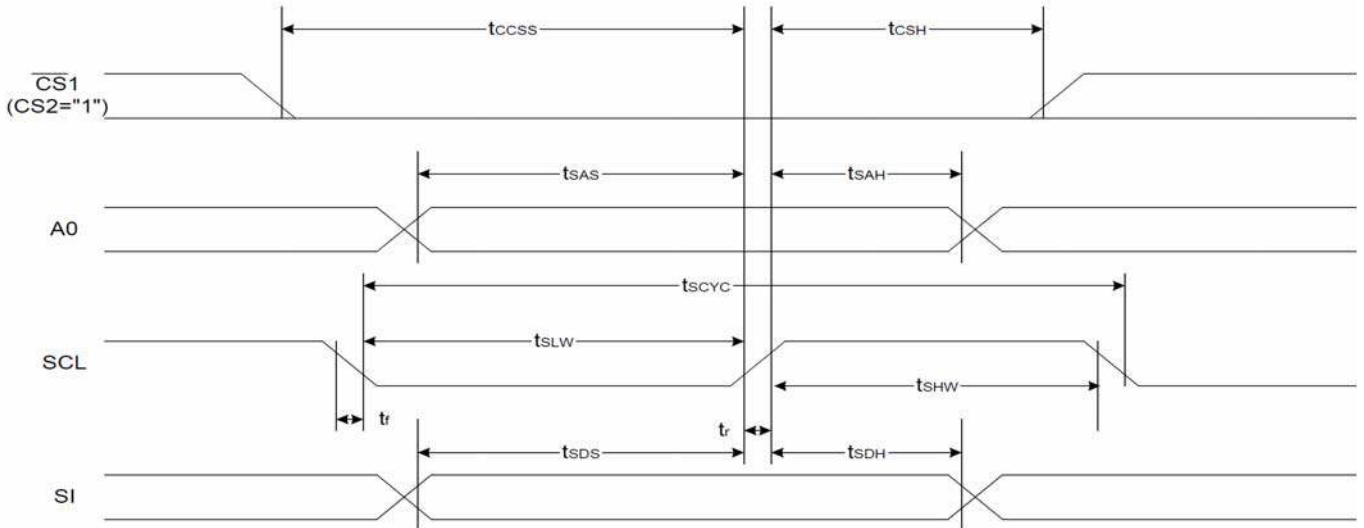

Item	Signal	Symbol	Condition	Rating		Units
				Min.	Max.	
4-line SPI Clock Period	SCL	$T_{scyc}$		50	—	ns
SCL "H" pulse width		$T_{shw}$		25	—	
SCL "L" pulse width		$T_{SLW}$		25	—	
Address setup time	A0	$T_{sAS}$		20	—	
Address hold time		$T_{sAH}$		10	—	
Data setup time	SI	$T_{SDS}$		20	—	
Data hold time		$T_{SDH}$		10	—	
CS-SCL time	CS	$T_{css}$		20	—	
CS-SCL time		$T_{csH}$		40	—	

Item	Signal	Symbol	Condition	Rating		Units
				Min.	Max.	
4-line SPI Clock Period	SCL	$T_{scyc}$		200	—	ns
SCL "H" pulse width		$T_{shw}$		80	—	
SCL "L" pulse width		$T_{SLW}$		80	—	
Address setup time	A0	$T_{sAS}$		60	—	
Address hold time		$T_{sAH}$		30	—	
Data setup time	SI	$T_{SDS}$		60	—	
Data hold time		$T_{SDH}$		30	—	
CS-SCL time	CS	$T_{css}$		40	—	
CS-SCL time		$T_{csH}$		100	—	

\*1 The input signal rise and fall time ( $t_r$ ,  $t_f$ ) are specified at 15 ns or less.  
 \*2 All timing is specified using 20% and 80% of  $V_{DD}$  as the standard.

### Reset Timing

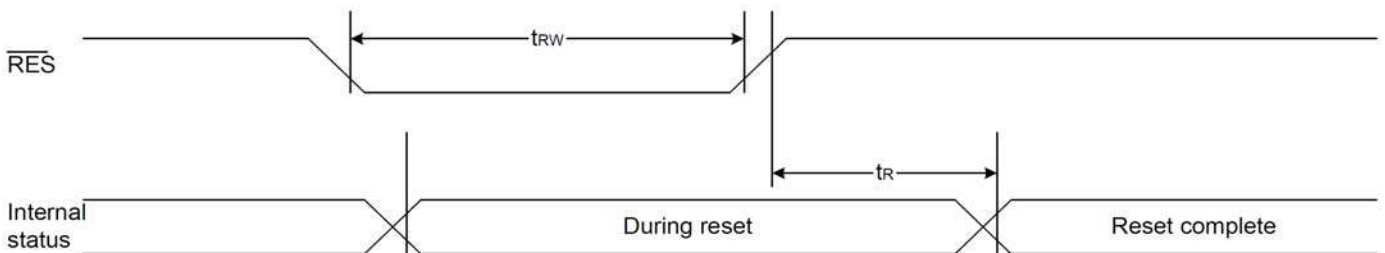

# COMMAND TABLE

(COMMAND FOR ST7565R)

Command	Command Code										Function		
	A0	/RD	/WR	D7	D6	D5	D4	D3	D2	D1		D0	
(1) Display ON/OFF	0	1	0	1	0	1	0	1	1	1	0	1	LCD display ON/OFF 0: OFF, 1: ON
(2) Display start line set	0	1	0	0	1	Display start address					0	Sets the display RAM display start line address	
(3) Page address set	0	1	0	1	0	1	1	Page address				0	Sets the display RAM page address
(4) Column address set upper bit Column address set lower bit	0	1	0	0	0	0	1	Most significant column address			0	Sets the most significant 4 bits of the display RAM column address.	
				0	0	0	0	Least significant column address			0	Sets the least significant 4 bits of the display RAM column address.	
(5) Status read	0	0	1	Status			0	0	0	0	0	0	Reads the status data
(6) Display data write	1	1	0	Write data							0	Writes to the display RAM	
(7) Display data read	1	0	1	Read data							0	Reads from the display RAM	
(8) ADC select	0	1	0	1	0	1	0	0	0	0	0	1	Sets the display RAM address SEG output correspondence 0: normal, 1: reverse
(9) Display normal/reverse	0	1	0	1	0	1	0	0	1	1	0	1	Sets the LCD display normal/ reverse 0: normal, 1: reverse
(10) Display all points ON/OFF	0	1	0	1	0	1	0	0	1	0	0	1	Display all points 0: normal display 1: all points ON
(11) LCD bias set	0	1	0	1	0	1	0	0	0	1	0	1	Sets the LCD drive voltage bias ratio 0: 1/9 bias, 1: 1/7 bias (ST7565R)
(12) Read-modify-write	0	1	0	1	1	1	0	0	0	0	0	0	Column address increment At write: +1 At read: 0
(13) End	0	1	0	1	1	1	0	1	1	1	0	0	Clear read/modify/write
(14) Reset	0	1	0	1	1	1	0	0	0	1	0	0	Internal reset
(15) Common output mode select	0	1	0	1	1	0	0	0	*	*	*	*	Select COM output scan direction 0: normal direction 1: reverse direction
(16) Power control set	0	1	0	0	0	1	0	1	Operating mode		0	0	Select internal power supply operating mode
(17) V <sub>0</sub> voltage regulator internal resistor ratio set	0	1	0	0	0	1	0	0	Resistor ratio		0	0	Select internal resistor ratio(Rb/Ra) mode
(18) Electronic volume mode set Electronic volume register set	0	1	0	1	0	0	0	0	0	0	0	1	Set the V <sub>0</sub> output voltage electronic volume register
				0	0	Electronic volume value					0		
(19) Static indicator ON/OFF Static indicator register set	0	1	0	1	0	1	0	1	1	0	0	1	0: OFF, 1: ON Set the flashing mode
				0	0	0	0	0	0	0	0	Mode	
(20) Booster ratio set	0	1	0	1	1	1	1	1	0	0	0	0	select booster ratio 00: 2x,3x,4x 01: 5x 11: 6x
				0	0	0	0	0	0	0	0	step-up value	
(21) Power save	0	1	0								0	Display OFF and display all points ON compound command	
(22) NOP	0	1	0	1	1	1	0	0	0	1	1	1	Command for non-operation
(23) Test	0	1	0	1	1	1	1	*	*	*	*	*	Command for IC test. Do not use this command



# LCD ARTWORK

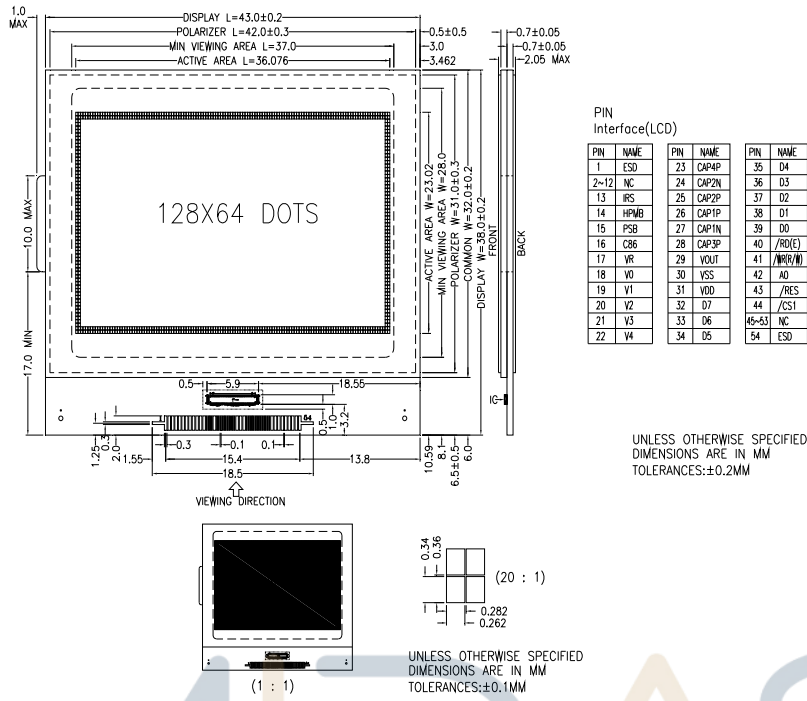

# SEG LAYOUT

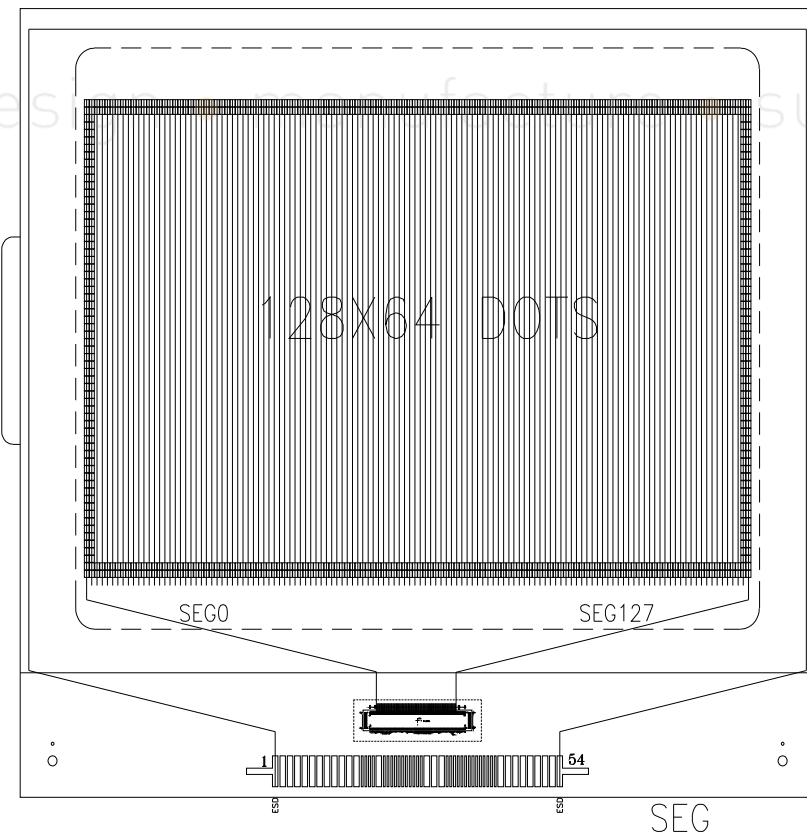



## RELIABILITY TEST

Operating life time: Longer than 50000 hours

(at room temperature without direct irradiation of sunlight)

Reliability characteristics shall meet following requirements.

TEMPERATURE TESTS	NORMAL GRADE
High temperature storage	+80°C * 96HR
Low temperature storage	-30°C * 96HR
High temperature operation	+70°C * 96HR
Low temperature operation	-20°C * 96HR
High temperature, High humidity	+60°C 90%RH 96HR
Thermal shock	-20°C * 30 min ← 10s ↓ 5Cycles 70°C * 30 min →
Vibration test	Frequency * Swing * Time 40Hz * 4mm * 4hrs
Drop test	Drop height * Times 1.0m * 6 times

## QUALITY DESCRIPTION & APPLICATION NOTE

Please refer to “General Inspection Criteria” document

design • manufacture • supply

