



MAX9249 Evaluation Kit

General Description

The MAX9249 evaluation kit (EV kit) provides a proven design to evaluate the MAX9249 gigabit multimedia serial link (GMSL) with spread spectrum and full-duplex control channel. The EV kit also includes Windows XP®, Windows Vista®, and Windows® 7-compatible software that provides a simple graphical user interface (GUI) for exercising the features of the MAX9249.

The EV kit comes with a MAX9249GCM/V+ installed.

For complete GMSL evaluation, order both the MAX9249 EV kit and its companion board, the MAX9260 EV kit.

Features

- ◆ Accepts 28-Bit Parallel Video and I²S Audio
- ◆ On-Board S/PDIF-to-I²S Audio Converter
- ◆ Windows XP-, Windows Vista-, and Windows 7-Compatible Software
- ◆ USB-PC Connection (Cable Included)
- ◆ USB Powered
- ◆ Proven PCB Layout
- ◆ Fully Assembled and Tested

Ordering Information

PART	TYPE
MAX9249EVKIT+	EV Kit

+Denotes lead(Pb)-free and RoHS compliant.

Note: The MAX9249 EV kit should be ordered with its companion board, the MAX9260 EV kit.

Component List

DESIGNATION	QTY	DESCRIPTION
BC5–BC28	24	0.1μF ±10%, 16V X5R ceramic capacitors (0402) Murata GRM155R61C104K
C1–C9	9	0.01μF ±10%, 25V X7R ceramic capacitors (0402) Murata GRM155R71E103K
C10–C18, C101–105, C111, C121, C131, C141, C151, C211–C214, C221, C231, C241, C251	27	0.1μF ±10%, 16V X7R ceramic capacitors (0603) TDK C1608X7R1C104K
C19, C20	2	0.22μF ±10%, 50V X7R ceramic capacitors (0805) Murata GRM21BR71H224K
C21, C31, C261	3	4.7μF ±20%, 25V X7R ceramic capacitors (1206) Murata GCM31CR71E475M
C22, C24, C25, C26, C32, C34, C109, C262, C264, C267	10	10μF ±20%, 16V X5R ceramic capacitors (1206) Murata GRM31CR61C106M

DESIGNATION	QTY	DESCRIPTION
C23, C33, C263	0	Not installed, capacitors (1206)
C106, C107, C122, C123	4	22pF ±5%, 50V C0G ceramic capacitors (0603) Murata GRM1885C1H220J
C108, C265, C268	3	1μF ±10%, 16V X5R ceramic capacitors (0603) TDK C1608X5R1C105K
C110	1	0.033μF ±10%, 25V X7R ceramic capacitor (0603) Murata GRM188R71E333K
C201, C202, C203	3	1μF ±20%, 6.3V X5R ceramic capacitors (0402) TDK C1005X5R0J105M
C205, C206, C232, C266, C269	5	0.01μF ±5%, 25V C0G ceramic capacitors (0603) TDK C1608C0G1E103J
C207	1	1000pF ±10%, 50V X7R ceramic capacitor (0805) Murata GCM216R71H102K

Windows, Windows XP, and Windows Vista are registered trademarks of Microsoft Corp.



MAX9249 Evaluation Kit

Evaluates: MAX9249

Component List (continued)

DESIGNATION	QTY	DESCRIPTION
C208	1	0.022 μ F \pm 10%, 25V X7R ceramic capacitor (0402) TDK C1005X7R1E223K
C233	0	Not installed, capacitor (0603)
C500, C527, C537, C547, C557, C567	6	100 μ F \pm 20%, 6.3V X5R ceramic capacitors (1210) Murata GRM32ER60J107M
C501, C502	2	1000pF \pm 10%, 50V X7R ceramic capacitors (0603) Murata GRM188R71H102K
C503, C504, C505, C511–C515, C521, C523, C531, C533, C541, C543, C551, C553, C560	17	0.1 μ F \pm 10%, 16V X7R ceramic capacitors (0603) Murata GRM188R71C104K
C510	1	10 μ F \pm 10%, 16V X7R ceramic capacitor (0603) Murata GRM188R71C106K
C520, C526, C530, C536, C540, C546, C550, C556	8	10 μ F \pm 20%, 6.3V X5R ceramic capacitors (0603) Murata GRM188R60J106M
C522, C532, C542, C552	4	220pF \pm 10%, 50V X7R ceramic capacitors (0603) Murata GRM188R71H221K
FB501–FB505	5	Ferrite beads (0603) Murata BLM18PG121SN1D
H1	1	72-pin (2 x 36) header
H2	1	10-pin (2 x 5) header
H3	0	Not installed, 10-pin (2 x 5) header
J1	1	High-speed automotive connector Rosenberger D4S20F-40MA5-Z
J2 JTAGU500	1	9-pin header (2 x 5, key pin 7)
J10	1	USB type-B, right-angle female receptacle
J21	1	Phono jack
J23	0	Not installed, SMA connector

DESIGNATION	QTY	DESCRIPTION
JU1, JU2, JU4–JU9, JU121, JU151, JU152, JU501, JU502, JU503	14	3-pin headers
JU10, JU21, JU22, JU23, JU31, JU153, JU154, JU191–JU194, JU210, JU261, JU500, JU520, JU530, JU540, JU550, JU560, JUCNTL0, JUCNTL1, JUCNTL2	22	2-pin headers
JU101–JU108, JU141–JU144, JU211–JU214	0	Not installed, 2-pin headers—shorted by PCB trace
L21, L22, L23, L31, L101, L261	6	Ferrite beads (0603) TDK MMZ1608R301A
L262	1	3.3 μ H \pm 10% inductor (0805) Murata LQM21NN3R3K10
L520, L530, L540, L550	4	1.8 μ H, 2.2A inductors (5mm x 5mm x 3mm) Sumida CDRH4D28NP-1R8NC
LED1, LED120, LED151–LED158	10	Red LEDs (0805)
LED2, LED500	2	Green LEDs (0805)
Q1, Q2, Q500	3	n-channel MOSFETs (SOT23) Central Semi 2N7002
R1, R2	2	45.3k Ω \pm 1% resistors (0603)
R3, R4	2	4.99k Ω \pm 1% resistors (0603)
R5, R11, R12, R111	4	2.2k Ω \pm 5% resistors (0603)
R13	1	0 Ω \pm 5% resistor (0603)
R14, R15, R123, R151–R158, R203	12	1k Ω \pm 5% resistors (0603)
R101, R102	2	27 Ω \pm 5% resistors (0603)
R103	1	1.5k Ω \pm 5% resistor (0603)
R104	1	470 Ω \pm 5% resistor (0603)

MAX9249 Evaluation Kit

Component List (continued)

Evaluates: MAX9249

DESIGNATION	QTY	DESCRIPTION
R112, R122, R211, R212	4	10k Ω \pm 5% resistors (0603)
R121	1	1.1k Ω \pm 5% resistor (0603)
R191, R192, R201, R202	4	4.7k Ω \pm 5% resistors (0603)
R205	1	75k Ω \pm 5% resistor (0603)
R208	1	3.01k Ω \pm 1% resistor (0603)
R233	0	Not installed, resistor (0603)
R500, R501, R502	3	1k Ω \pm 5% resistors (0603)
R503–R506	4	10k Ω \pm 5% resistors (0603)
R507	1	160 Ω \pm 5% resistor (0603)
R510–R515	6	5.1k Ω \pm 5% resistors (0603)
R521, R531, R541, R551	4	10 Ω \pm 5% resistors (0603)
R522	1	110k Ω \pm 5% resistor (0603)
R524	1	75k Ω \pm 1% resistor (0603)
R525	1	24k Ω \pm 1% resistor (0603)
R532	1	82k Ω \pm 5% resistor (0603)
R534	1	30.1k Ω \pm 1% resistor (0603)
R535	1	14k Ω \pm 1% resistor (0603)
R542	1	39k Ω \pm 5% resistor (0603)
R544	1	22.1k Ω \pm 1% resistor (0603)
R545	1	44.2k Ω \pm 1% resistor (0603)
R552	1	68k Ω \pm 5% resistor (0603)
R561	1	1.5k Ω \pm 1% resistor (0603)
R562	1	1k Ω \pm 1% resistor (0603)
RT500–RT504	5	100 Ω \pm 5% resistors (0402)
SW1	1	3-pin header
SW122, SW150–SW157, SW221	10	Momentary switches
TP500	1	Black multipurpose test point
TP501	1	White multipurpose test point
U1	1	Gigabit multimedia serial link, LVDS inputs (48 TQFP-EP*) Maxim MAX9249GCM/V+
U2	1	1.8V, 500mA LDO regulator (8 μ MAX [®]) Maxim MAX1792EUA18+ (Top Mark: AAAA)

DESIGNATION	QTY	DESCRIPTION
U3, U26	2	3.3V, 500mA LDO regulators (8 μ MAX) Maxim MAX1792EUA33+ (Top Mark: AAAC)
U10	1	UART-to-USB converter (32 TQFP)
U11	1	93C46 type 3-wire EEPROM 16-bit architecture (8 SO)
U12	1	Ultra-high-speed micro-controller (44 TQFP) Maxim DS89C450-ENL+
U13	1	Quad three-state buffer (14 SO) Fairchild 74AC125SC
U14	1	Level translator (14 TSSOP) Maxim MAX3378EEUD+
U15	1	I ² C I/O expander (24 QSOP) Maxim MAX7324AEG+
U19	1	Dual bidirectional level translator (8 SOT23) Maxim MAX3373EEKA+ (Top Mark: AAKS)
U20	1	Digital audio receiver (28 TSSOP)
U21	1	16-bit, dual-supply bus transceiver (48 TSSOP)
U22	1	Low-power, dual-voltage μ P supervisor (5 SC70) Maxim MAX6736XKTGD3+ (Top Mark: AFS)
U23, U24	2	2:1 noninverting multiplexers (SC70) Fairchild NC7SV157P6X_NL (Top Mark: VF7)
U25	1	Schmitt trigger buffer (5 SC70) Fairchild NC7SV17P5X_NL (Top Mark: V17)

μ MAX is a registered trademark of Maxim Integrated Products, Inc.

MAX9249 Evaluation Kit

Component List (continued)

DESIGNATION	QTY	DESCRIPTION
U500	1	Cyclone III FPGA (324 FBGA) Altera EP3C25F324C8N
U510	1	16M x 16-bit flash memory (64 Easy BGA)
U520, U530, U540	3	Step-down DC-to-DC regulators (8 SO) Maxim MAX1951ESA+
U550	1	Step-down DC-to-DC regulator (8 SO) Maxim MAX1952ESA+
U560	1	0.2V dropout LDO regulator (10 μ MAX) Maxim MAX8516EUB+
Y10	1	6MHz crystal (HCM49) Hong Kong X'tals SSL60000N1HK188F0-0

DESIGNATION	QTY	DESCRIPTION
Y12	1	14.7456MHz crystal (HCM49) Hong Kong X'tals SSM14745N1HK188F0-0
Y23	1	12MHz, 3.3V low-jitter clock (7mm x 5mm)
Y500	1	50MHz clock oscillator Hongkong X'tals C437BM5000000AE00
—	1	USB high-speed A-to-B cables, 6ft
—	30	Shunts
—	1	PCB: MAX9249 EVALUATION KIT+

*EP = Exposed pad.

Component Suppliers

SUPPLIER	PHONE	WEBSITE
Altera Corp.	800-800-3753	www.altera.com
Central Semiconductor Corp.	631-435-1110	www.centralsemi.com
Fairchild Semiconductor	888-522-5372	www.fairchildsemi.com
Hong Kong X'tals Ltd.	852-35112388	www.hongkongcrystal.com
MD ELEKTRONIK GmbH	011-49-86-38-604-0	www.md-elektronik-gmbh.de
Murata Electronics North America, Inc.	770-436-1300	www.murata-northamerica.com
Sumida Corp.	847-545-6700	www.sumida.com
Rosenberger Hochfrequenztechnik GmbH	011-49-86 84-18-0	www.rosenberger.de
TDK Corp.	847-803-6100	www.component.tdk.com

Note: Indicate that you are using the MAX9249 when contacting these component suppliers.

MAX9249 EV Kit Files

FILE	DESCRIPTION
INSTALL.EXE	Installs the EV kit files on your computer
MAX9249.EXE	Application program
CDM20600.EXE	Installs the USB device driver
UNINSTALL.EXE	Uninstalls the EV kit software
USB_Driver_Help_200.PDF	USB driver installation help file

MAX9249 Evaluation Kit

Quick Start

Required Equipment

- MAX9249 EV kit (USB cable included)
- MAX9260 EV kit (USB cable included)
- 2m Rosenberger cable assembly (included in MAX9260 EV kit)
- Parallel data source (e.g., digital video)
- Optional: Function generator (needed only if parallel data lacks a pixel clock)
- Optional: I²S or S/PDIF audio source
- Optional: Pair of 8Ω speakers
- Optional: 3.5mm stereo headphones (16Ω or greater)
- Windows XP, Windows Vista, or Windows 7 PC with a spare USB port (direct 500mA connection required; do not use a hub)

Note: In the following sections, software-related items are identified by bolding. Text in **bold** refers to items directly from the EV kit software. Text in **bold and underlined** refers to items from the Windows operating system.

Procedure

The MAX9249 EV kit is fully assembled and tested. Follow the steps below to verify board operation:

- 1) Visit www.maxim-ic.com/evkitsoftware to download the latest version of the EV kit software, 9249Rxx.ZIP. Save the EV kit software to a temporary folder and uncompress the ZIP file.
- 2) Install the EV kit software and USB driver on your computer by running the INSTALL.EXE program inside the temporary folder. The program files are copied to your PC and icons are created in the Windows **Start | Programs** menu. During software installation, some versions of Windows may show a warning message indicating that this software is from an unknown publisher. This is not an error condition and it is safe to proceed with installation. Administrator privileges are required to install the USB device driver on Windows.
- 3) Verify that all jumpers are in their default positions, as shown in Table 1.
- 4) Connect the Rosenberger cable from MAX9249 EV kit connector J1 to MAX9260 EV kit connector J1.
- 5) Connect the parallel data source to header H1 (if using static data without a pixel clock, use an external function generator to drive PCLK_IN).
- 6) *Optional Audio Demo:* Connect the S/PDIF audio source (e.g., DVD player digital output) to MAX9249 EV kit phono jack J21. Or, connect an I²S audio source to header H1 and remove jumper JU210. Connect speakers to MAX9260 EV kit SPKR_L+/SPKR_L- and SPKR_R+/SPKR_R- oval pads, or plug headphones into J206 headphone jack.
- 7) Connect the USB cable from the PC to the EV kit board. A Windows message appears when connecting the EV kit board to the PC for the first time. Each version of Windows has a slightly different message. If you see a Windows message stating **ready to use**, then proceed to the next step. Otherwise, open the USB_Driver_Help_200.PDF document in the Windows **Start | Programs** menu to verify that the USB driver was installed successfully.
- 8) Verify that MAX9249 EV kit LED120 lights up, indicating that the microcontroller is powered and enabled.
- 9) Verify that MAX9260 EV kit LED120 lights up, indicating that the microcontroller is powered and enabled.
- 10) Verify that MAX9260 EV kit LED2 lights up, indicating that the link has been successfully established. If LED2 is off or LED1 is on, double-check that the PCLK_IN signal is clocking data.
- 11) *Optional Audio Demo:* Press and release switch SW122 on both of the MAX9249 and MAX9260 EV kits to enable this S/PDIF-to-I²S and I²S-to-audio DAC demonstration circuitry. If I²S or S/PDIF audio was provided to the MAX9249 EV kit, audio should now be heard from the speakers or headphones previously connected to the MAX9260 EV kit.
- 12) Start the MAX9249 EV kit software by opening its icon in the Windows **Start | Programs** menu. The EV kit software configuration window appears, as shown in Figure 7.
- 13) Press the **Connect** button and the configuration window disappears.
- 14) The EV kit software main window appears, as shown in Figure 1.
- 15) Press the **Read All** button to read all registers on the MAX9249 and MAX9260.
- 16) *I²C Slave Device Demo:* Make sure MAX9260 EV kit jumpers JU151–JU154 are in the 1-2 position.

MAX9249 Evaluation Kit

- 17) In the software's MAX7324 tab (Figure 4), press the **Search for MAX7324** button. Verify that the **MAX7324 Device Address** drop-down list shows **0xDA (JU151=1-2 JU152=1-2)**.
- 18) Press the **LED151-LED158 ON** button. Verify that MAX9260 EV kit LED151–LED158 turn on.
- 19) Press the **LEDs Alternating** button. Verify that MAX9260 EV kit LED151, LED153, LED156, and LED158 turn off.
- 20) *GPIO Demo*: In the software's MAX9260 tab (Figure 3), scroll down to **Register 0x06**. Uncheck the **GPIO1OUT** checkbox and press the **Write** button. Verify that MAX9260 EV kit LED4 turns off.
- 21) Uncheck the **GPIO0OUT** checkbox and press the **Write** button. Verify that MAX9260 EV kit LED3 turns off.
- 22) Check the **GPIO1OUT** checkbox and press the **Write** button. Verify that MAX9260 EV kit LED4 turns on.
- 23) Check the **GPIO0OUT** checkbox and press the **Write** button. Verify that MAX9260 EV kit LED3 turns on.
- 24) *INT Demo*: Toggle MAX9260 EV kit switch SW2 up. Verify that MAX9249 EV kit LED1 turns on, indicating that MAX9260 INT input is asserted.
- 25) In the software's MAX9260 tab, scroll to **Register 0x06** and press the **Read** button. Verify that the **INT** checkbox is checked, indicating that MAX9260 INT input is asserted.
- 26) Toggle MAX9260 EV kit switch SW2 down. Verify that MAX9249 EV kit LED1 turns off, indicating that MAX9260 INT input is not asserted.
- 27) In the software's MAX9260 tab, scroll to **Register 0x06** and press the **Read** button. Verify that the **INT** checkbox is not checked, indicating that MAX9260 INT input is not asserted.

Detailed Description of Software

The main window of the evaluation software (Figure 1) shows a block diagram representing the MAX9249/MAX9260 system. The left column shows MAX9249 input data sources, and the right column shows MAX9260 output data sinks.

The **Change Configuration** button (Figure 1) brings up the **Configuration** window (Figure 7), allowing the software GUI to select which side of the link the USB cable should be plugged in to. Controlling from the MAX9260 side requires changing some jumper settings as described in this window. If the MAX9249

and MAX9260 device addresses have been previously changed from their factory power-on-reset values, the new addresses must be specified in the **Configuration** window to allow register access.

The **Baud Rate** drop-down list sets the communications baud rate. The USB link uses the same baud rate as the MAX9249/MAX9260. Note that the baud rate should only be changed one step at a time.

The **Read All** button reads all of the MAX9249/MAX9260 device registers. The **Reset to Default Values** button restores recommended factory settings, and the **Write All** button writes all MAX9249 and MAX9260 device registers with the values shown in the GUI.

The **MAX9249** tab sheet (Figure 2) provides direct access to all registers of the MAX9249 and the **MAX9260** tab sheet (Figure 3) provides direct access to all registers of the MAX9260. Each register has its own **Read** and **Write** button. The small circle next to the **Read** button turns yellow to indicate an attempt to read or write, red to indicate a failed read or write, and green to indicate a successful read or write operation.

The **MAX7324** tab sheet (Figure 4) controls the I²C I/O expander on the remote side of the link. When USB is plugged into the MAX9249 EV kit, the MAX7324 tab sheet controls the MAX7324 (U15) on the MAX9260 EV kit. Note that the MAX7324 actually has two device addresses; for simplicity, the software GUI only displays the device address associated with MAX7324 outputs. For details, refer to the MAX7324 IC data sheet.

The **PRBS Test** tab sheet (Figure 5) uses the MAX9260 registers to perform a pseudorandom bit sequence (PRBS) error-rate test. Select the test duration (maximum 32767s = 9.1hr) and press the **Start** button. The software GUI configures the MAX9260 to begin the PRBS test, counts down the specified delay time, and then reports the final value of the MAX9260 PRBSERR register.

The **Interface History and Low Level Access** tab sheet (Figure 6) shows the recent low-level communications activity between the software GUI and the MAX9249/MAX9260. The **Register Access** group box provides arbitrary device read/write control, supporting additional user-supplied devices besides the on-board MAX9249, MAX9260, and MAX7324. The **Device Address**, **Register**, and **Data** drop-down lists specify the device address and the register within the device, as well as one optional byte of data to be written. Pressing the **Write Register** button writes one byte of data to the specified device register. **Read Register** reads the specified device register and reports the results into the

MAX9249 Evaluation Kit

Interface History window. Devices that are not register-based (such as the MAX7324) are supported by **Send Data (no register)** and **Receive Data (no register)**. User-supplied devices requiring other interface protocols must use **Raw TX byte codes** to communicate. Note that in bypass mode, raw data is passed to the user-supplied slave device directly without modification.

Detailed Description of Hardware

The MAX9249 EV kit provides a proven layout for the MAX9249. On-board level translators, S/PDIF-to-I²S audio, and an easy-to-use USB-PC connection are included on the EV kit.

The MAX9249 EV kit board layout is divided into four principal sections.

From header H3 to connector J1 are the support components specific to the MAX9249. On-board LDO regulator U2 powers the AVDD, DVDD, and IOVDD supplies from VIN. Jumper JU9 optionally connects VIN to the link cable, powering the remote EV kit board.

Between headers H3 and H1, an Altera Cyclone III FPGA (U500) converts parallel video signals from header H1 into LVDS video at header H3. Jumper JU500 powers the FPGA's regulators U520–U560 from the USB.

Below header H1, the board layout has three sections: microcontroller (U10–U14), I²C slave device (U15), and audio (U20–U25). The microcontroller and I²C slave device sections are identical on the MAX9249 and MAX9260 EV kits.

The audio section of the MAX9249 EV kit contains S/PDIF-to-I²S audio converter circuits (U20–U25), which can be disabled by JU210 for applications already having I²S audio.

The audio section of the MAX9260 EV kit contains I²S-to-audio DAC circuits (U20, U21) and a Class D stereo power amplifier (U25). The audio DAC circuits are similar to the MAX9850 EV kit, and the power amplifier circuit is similar to the MAX9701 EV kit.

Evaluating LVDS Input Signals

If the available video source uses 7-bit LVDS output format instead of parallel CMOS video, then adapt the EV kit board as follows. With power off and the USB unconnected, cut the five pairs of LVDS traces between H3 and U500 and install a header at H3. Disconnect the FPGA power from the USB by removing the shunt from jumper JU500. Follow the *Quick Start* procedures, except for step 5, and apply LVDS signals at header H3. Refer to the MAX9249 IC data sheet for LVDS specifications.

User-Supplied Interface

To use the MAX9249 EV kit with a user-supplied interface, first cut the PCB traces at jumpers JU141 and JU142. Next, apply your own TX/SCL signal at the U1 side of JU141 and RX/SDA at the U1 side of JU142. Refer to the MAX9249 and MAX9259/MAX9260 IC data sheets for details about UART protocols for base mode, write data format, read data format, selecting base mode or bypass mode, and selecting UART or I²C slave device.

User-Supplied Power Supply

The MAX9249 and MAX9260 EV kits are powered completely from the USB port by default. The 5V USB bus power is supplied to the remote EV kit over the link cable by default. Jumper JU10 powers the link cable (VBUS) from the 5V USB supply, and jumper JU9 connects VBUS to the VIN power supply.

To provide external power to each EV kit's VIN, and still power both microcontrollers from the USB, remove the shunt from jumper JU9, but leave the shunt at jumper JU10 installed. VBUS carries the USB 5V bus power to the remote EV kit board, but external user-supplied VIN supplies are required to power the MAX9249 and the MAX9260.

To provide different power supplies to DVDD, AVDD, and IOVDD, remove the shunts from jumpers JU21, JU22, and JU23, and apply external user-supplied power at the DVDD, AVDD, and IOVDD oval pads.

The I²S audio link demonstration requires both MAX9249 EV kit and MAX9260 EV kit microcontrollers (U12) to be powered, otherwise the on-board S/PDIF-to-I²S converter or the I²S audio DAC does not initialize.

Detailed Description of Firmware

The DS89C450 microcontroller (U12) runs custom firmware, which ensures that no breaks occur within register read/write commands. The firmware records 9-bit, even-parity data received from the USB interface while RTS is set, and plays back the 9-bit data with 1.5 stop bits timing when RTS is cleared. Data received from the MAX9249 is relayed to the USB immediately.

The audio chips are initialized by an I²C command sequence sent by the firmware when the microcontroller is reset. The same firmware runs on both the MAX9249 and MAX9260 EV kit boards, so this initialization sequence covers both the S/PDIF-to-I²S converter and the MAX9850 I²S stereo audio DAC. Pressing switch SW122 resets the microcontroller, resending the audio I²C initialization commands.

MAX9249 Evaluation Kit

The firmware also supports a small set of commands, available when RTS is clear. Since all register read/write requests are sent with RTS set, there is no conflict between register data and firmware commands. These firmware commands are issued automatically by the MAX9249 EV kit software GUI. The following information is provided for reference only.

Firmware command “?” prints the firmware version banner message and a brief command list.

Firmware command “B” changes the baud rate by changing the internal TH1 baud-rate divisor. Refer to firmware help command “?” for details. Pressing switch SW122 resets the USB baud rate to 921600 baud. The

software GUI automatically sends the baud-rate change command.

Firmware command “T” supports waking up the MAX9249 from the MAX9260 side of the link. Command “T” performs a dummy read, followed by a delay on the order of 1ms to 8ms, and finally writes a register value. For example, send “T810558800483” to read from device address 0x81 register 0x05, delay 4ms, then write to device address 0x80 register 0x04 data 0x83. This is the MAX9249 wake-up sequence for the default device addresses. The software GUI automatically sends this command when the **Wake Up MAX9249** button is pressed.

Table 1. Jumper Descriptions

JUMPER	SIGNAL	SHUNT POSITION	DESCRIPTION
JUCNTL0	CNTL0	1-2	CNTL0 = GND
		Open*	CNTL0 = unconnected
JUCNTL1	CNTL1	1-2	CNTL1 = GND
		Open*	CNTL1 = unconnected
JUCNTL2	CNTL2	1-2	CNTL2 = GND
		Open*	CNTL2 = unconnected
JU1	CDS	1-2	CDS = high; optional peripheral attached to MAX9249
		2-3*	CDS = low; ECU attached to MAX9249; connect USB to MAX9249 EV kit
		Open	Reserved
JU2	BWS	1-2*	BWS = high
		2-3	BWS = low
JU4	DRS	1-2*	DRS = high
		2-3	DRS = low
JU5	SSEN	1-2*	SSEN = high
		2-3	SSEN = low
JU6	$\overline{\text{PWN}}$	1-2*	$\overline{\text{PWN}}$ = high
		2-3	$\overline{\text{PWN}}$ = low
JU7	$\overline{\text{AUTOS}}$	1-2*	$\overline{\text{AUTOS}}$ = high
		2-3	$\overline{\text{AUTOS}}$ = low
JU8	H1 odd pins	Open*	H1 odd-numbered pins connect to GND through R13
		1-2	H1 odd-numbered pins connect to IOVDD; R13 must be open
		2-3	H1 odd-numbered pins connect to GND
JU9	Bus power	1-2*	J1 pin 1 connects to VIN
		2-3	J1 pin 1 connects to GND
		Open	J1 pin 1 is not connected
JU10	Bus power	1-2*	J1 pin 1 connects to USB 5V
		Open	USB power is not connected to link cable power
JU21	AVDD	1-2*	AVDD power from 1.8V LDO U2, powered by VIN
		Open	AVDD must be provided from an external source

MAX9249 Evaluation Kit

Evaluates: MAX9249

Table 1. Jumper Descriptions (continued)

JUMPER	SIGNAL	SHUNT POSITION	DESCRIPTION
JU22	DVDD	1-2*	DVDD power from 1.8V LDO U2, powered by VIN
		Open	DVDD must be provided from an external source
JU23	IOVDD	1-2*	IOVDD power from 1.8V LDO U2, powered by VIN
		Open	IOVDD must be provided from an external source
JU31	LVDSVDD	1-2*	LVDSVDD is powered from 3.3V LDO U3, powered by VIN
		Open	LVDSVDD must be powered from an external user-supplied source
JU121	Reserved	Not installed*	Reserved for factory diagnostic tests
JU141	TX/SCL	Not installed*	Connects U1 to U12 through level translator U14
JU142	RX/SDA	Not installed*	Connects U1 to U12 through level translator U14
JU143	LFLT	Not installed*	Connects U1 to USB through level translator U14
JU144	INT	Not installed*	Connects U1 to USB through level translator U14
JU151	U15 AD2	1-2*	Selects U15 I ² C device address
		2-3	Selects U15 I ² C device address
		Open	Reserved for factory diagnostic tests
JU152	U15 AD0	1-2*	Selects U15 I ² C device address
		2-3	Selects U15 I ² C device address
		Open	Reserved for factory diagnostic tests
JU153	U15 SDA	1-2*	Connects U15 MAX7324 to I ² C bus; MS must be low (SW1) and CDS must be high (JU1 = 1-2 on both boards)
		Open	Disconnects U15 MAX7324 from I ² C bus; MS may be high (SW1)
JU154	U15 SCL	1-2*	Connects U15 MAX7324 to I ² C bus; MS must be low (SW1) and CDS must be high (JU1 = 1-2 on both boards)
		Open	Disconnects U15 MAX7324 from I ² C bus; MS may be high (SW1)
JU191	AUDIO-SCL	1-2*	U12 sends I ² C initialization commands to audio chip U20
		Open	Disconnects audio I ² C bus pullup resistor
JU192	AUDIO-SDA	1-2*	U12 sends I ² C initialization commands to audio chip U20
		Open	Disconnects audio I ² C bus
JU193	AUDIO-SCL	1-2*	U12 sends I ² C initialization commands to audio chip U20
		Open	Disconnects audio I ² C bus pullup resistor
JU194	AUDIO-SDA	1-2*	U12 sends I ² C initialization commands to audio chip U20
		Open	Disconnects audio I ² C bus
JU210	U21 OE	1-2*	J21 S/PDIF input drives I ² S audio to H1 and U1
		Open	External user-supplied I ² S can be connected to H1
JU211	I ² S WS	Not installed*	J21 S/PDIF input drives I ² S audio to H1 and U1
		Open	Disconnects I ² S signals
JU212	I ² S SCK	Not installed*	J21 S/PDIF input drives I ² S audio to H1 and U1
		Open	Disconnects I ² S signals
JU213	I ² S SD	Not installed*	J21 S/PDIF input drives I ² S audio to H1 and U1
		Open	Disconnects I ² S signals
JU214	I ² S MCLK	Not installed*	J21 S/PDIF input drives I ² S audio to H1 and U1
		Open	Disconnects I ² S master clock

MAX9249 Evaluation Kit

Evaluates: MAX9249

Table 1. Jumper Descriptions (continued)

JUMPER	SIGNAL	SHUNT POSITION	DESCRIPTION
JU261	VMOD	1-2*	VMOD audio power from +3.3V LDO U26, powered by VIN
		Open	VMOD audio power must be provided from an external +3.3V source
JU500	FPGA	1-2*	VCC5 power from USB+5V
		Open	VCC5 power must be provided from an external source
JU501	FPGA	1-2*	Reserved
JU502	FPGA	Open*	Reserved
JU503	FPGA	Open*	Reserved
JU520	FPGA	1-2*	VCC33 power from 3.3V regulator U520, powered by VCC5
		Open	VCC33 must be provided from an external source
JU530	FPGA	1-2*	VCC25 power from 2.5V regulator U530, powered by VCC5
		Open	VCC25 must be provided from an external source
JU540	FPGA	1-2 *	VCC12 power from 1.2V regulator U540, powered by VCC5
		Open	VCC12 must be provided from an external source
JU550	FPGA	1-2*	VCC18 power from 1.8V regulator U550, powered by VCC5
		Open	VCC18 must be provided from an external source
JU560	FPGA	1-2*	VCC125 power from 1.25V regulator U560, powered by VCC18
		Open	VCC125 must be provided from an external source
SW1	MS	1-2	MS = high; full-duplex bypass mode; device registers not accessible
		2-3*	MS = low; half-duplex base mode; required when writing to device registers or when using external I ² C peripheral

*Default position.

MAX9249 Evaluation Kit

Evaluates: MAX9249

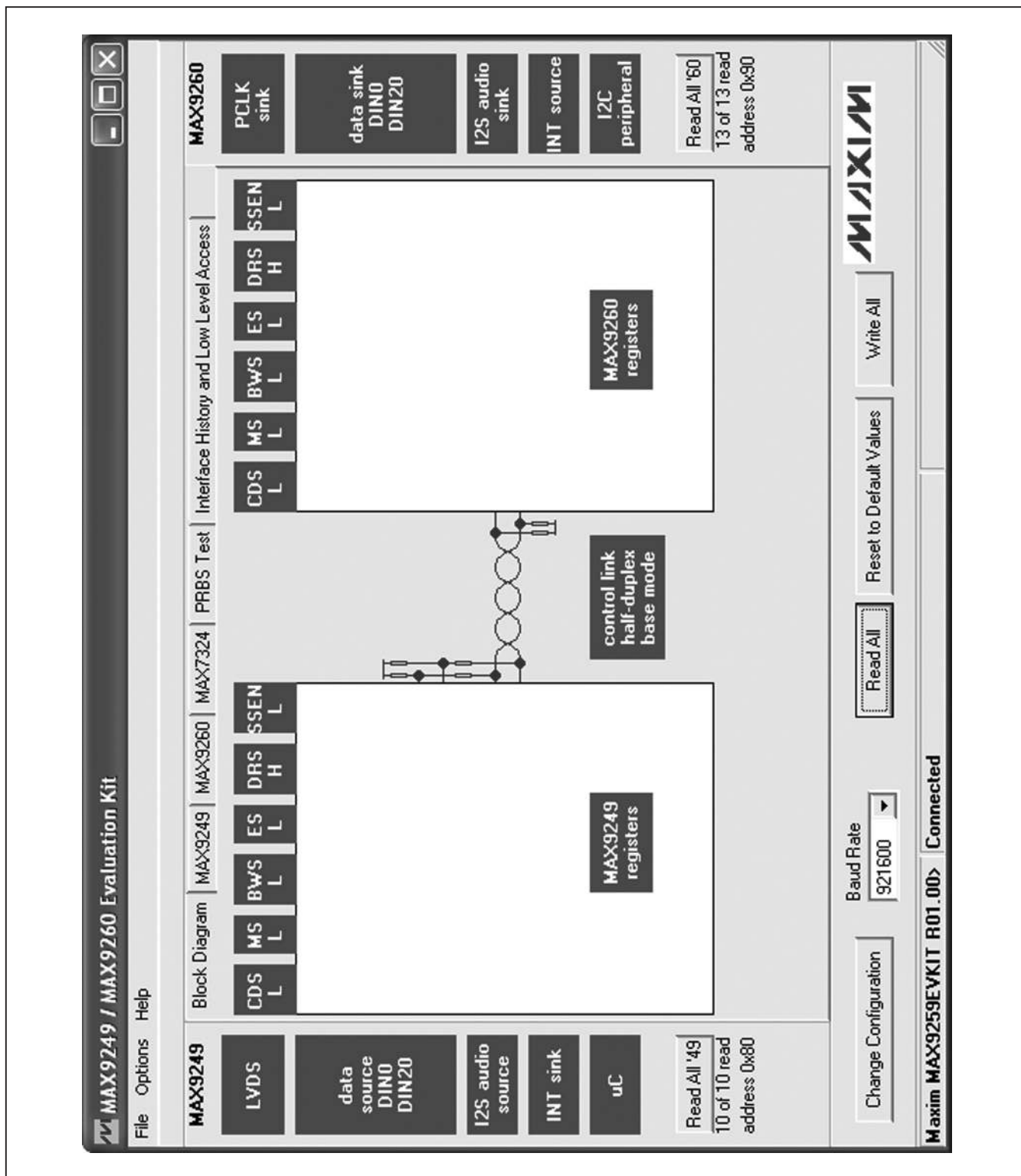

Figure 1. MAX9249/MAX9260 EV Kit Software Main Window (Block Diagram Tab)

Evaluates: MAX9249

MAX9249 Evaluation Kit

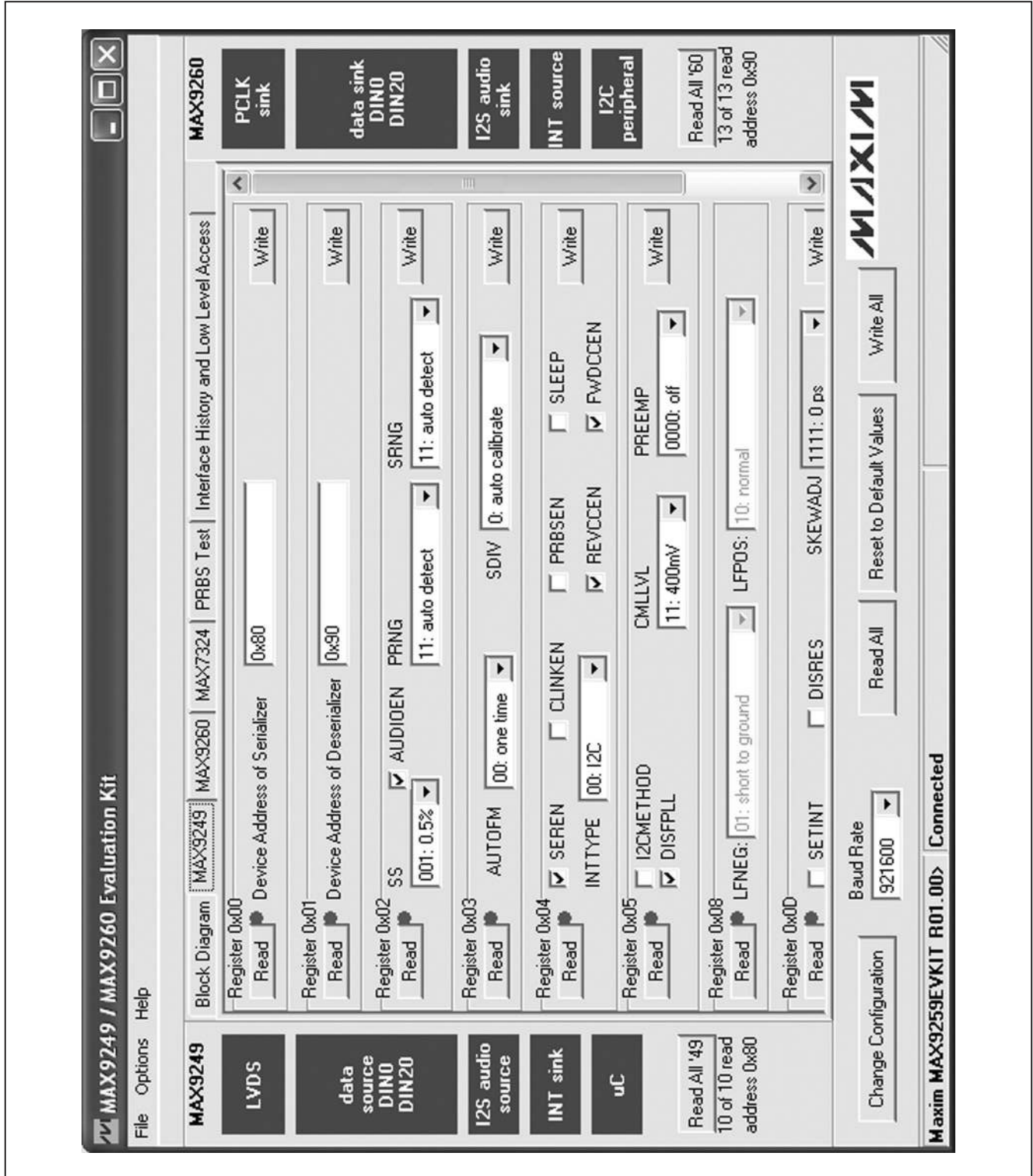

Figure 2. MAX9249/MAX9260 EV Kit Software Main Window (MAX9249 Tab)

MAX9249 Evaluation Kit

Evaluates: MAX9249

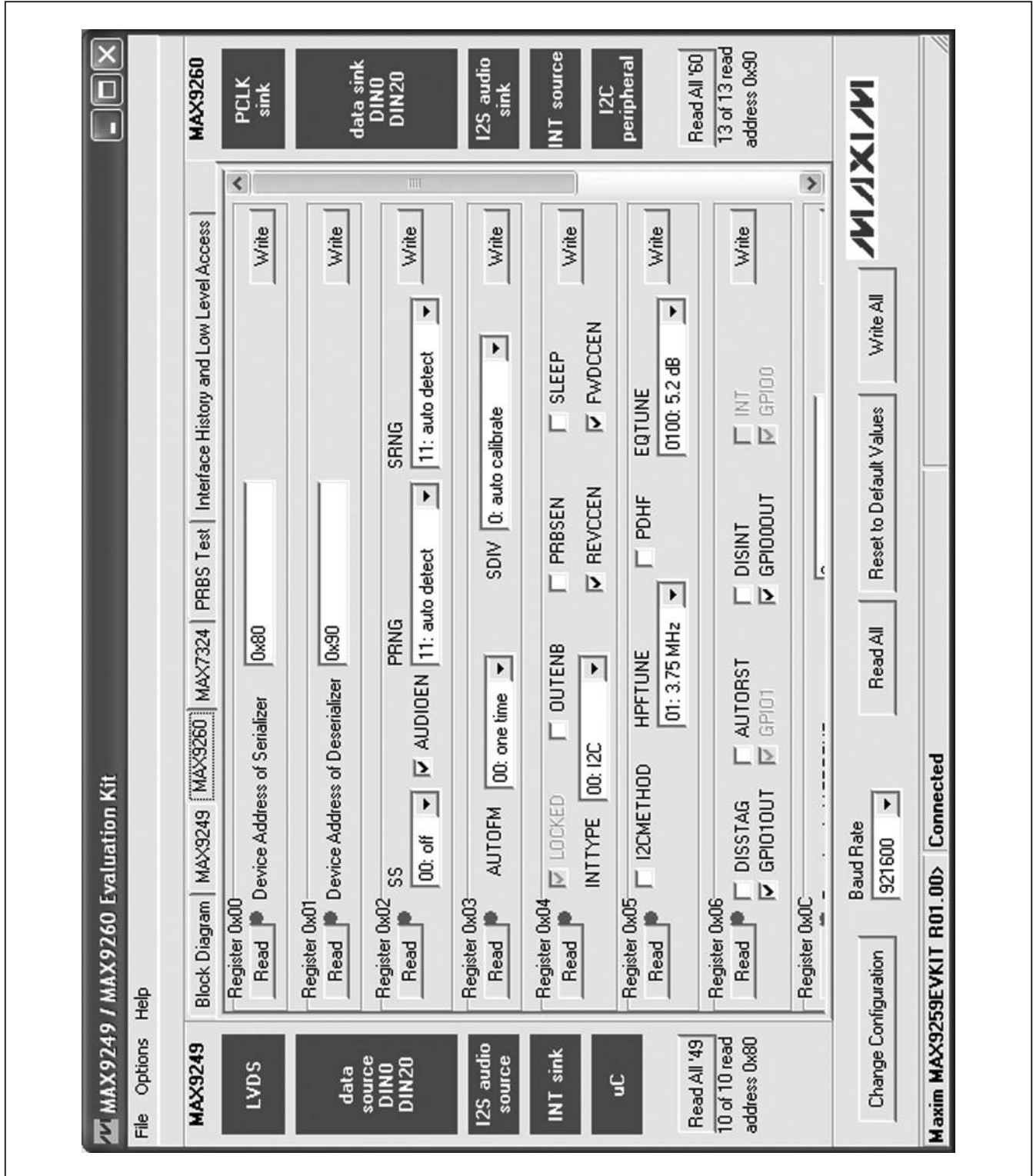

Figure 3. MAX9249/MAX9260 EV Kit Software Main Window (MAX9260 Tab)

MAX9249 Evaluation Kit

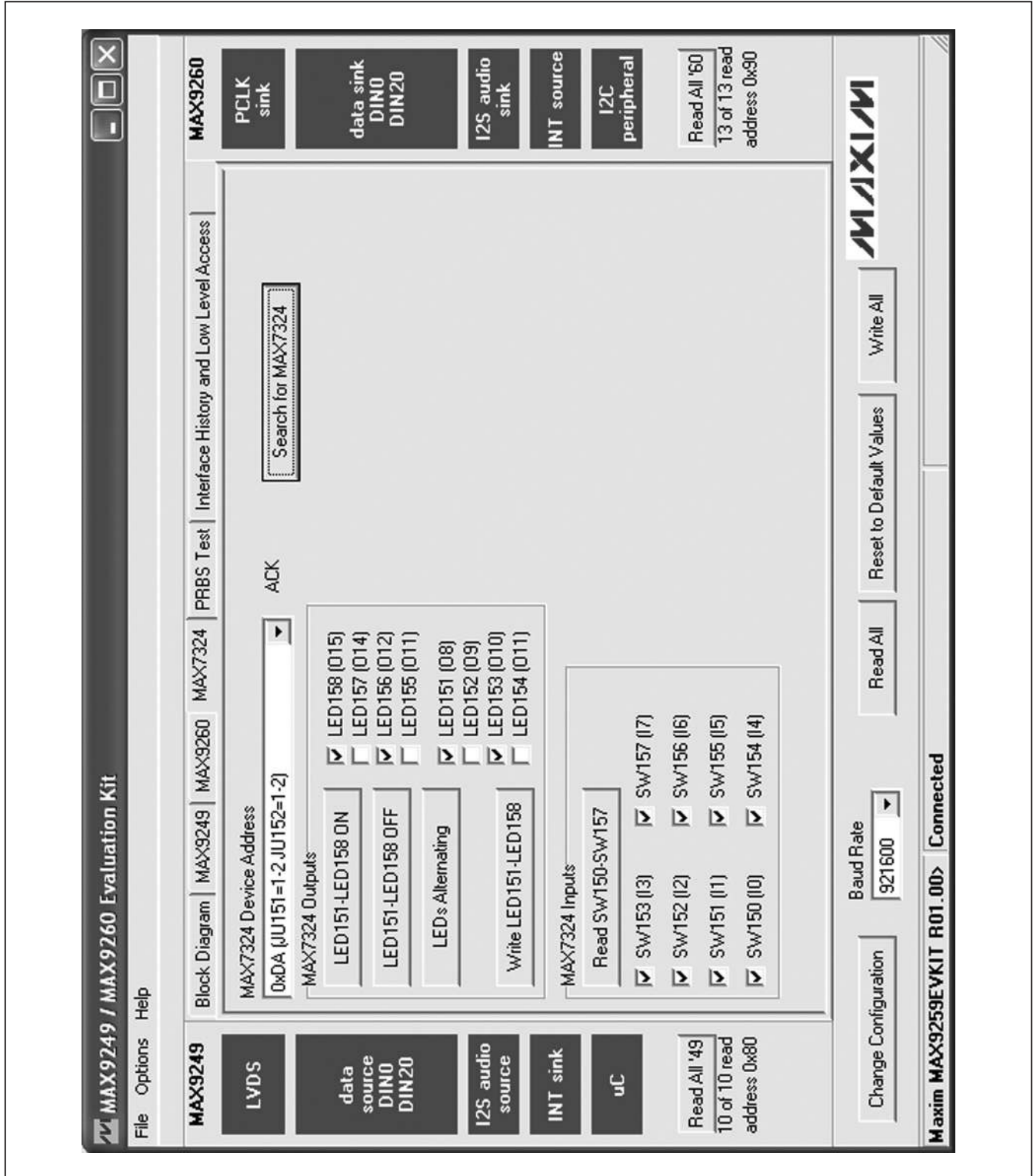

Figure 4. MAX9249/MAX9260 EV Kit Software Main Window (MAX7324 Tab)

MAX9249 Evaluation Kit

Evaluates: MAX9249

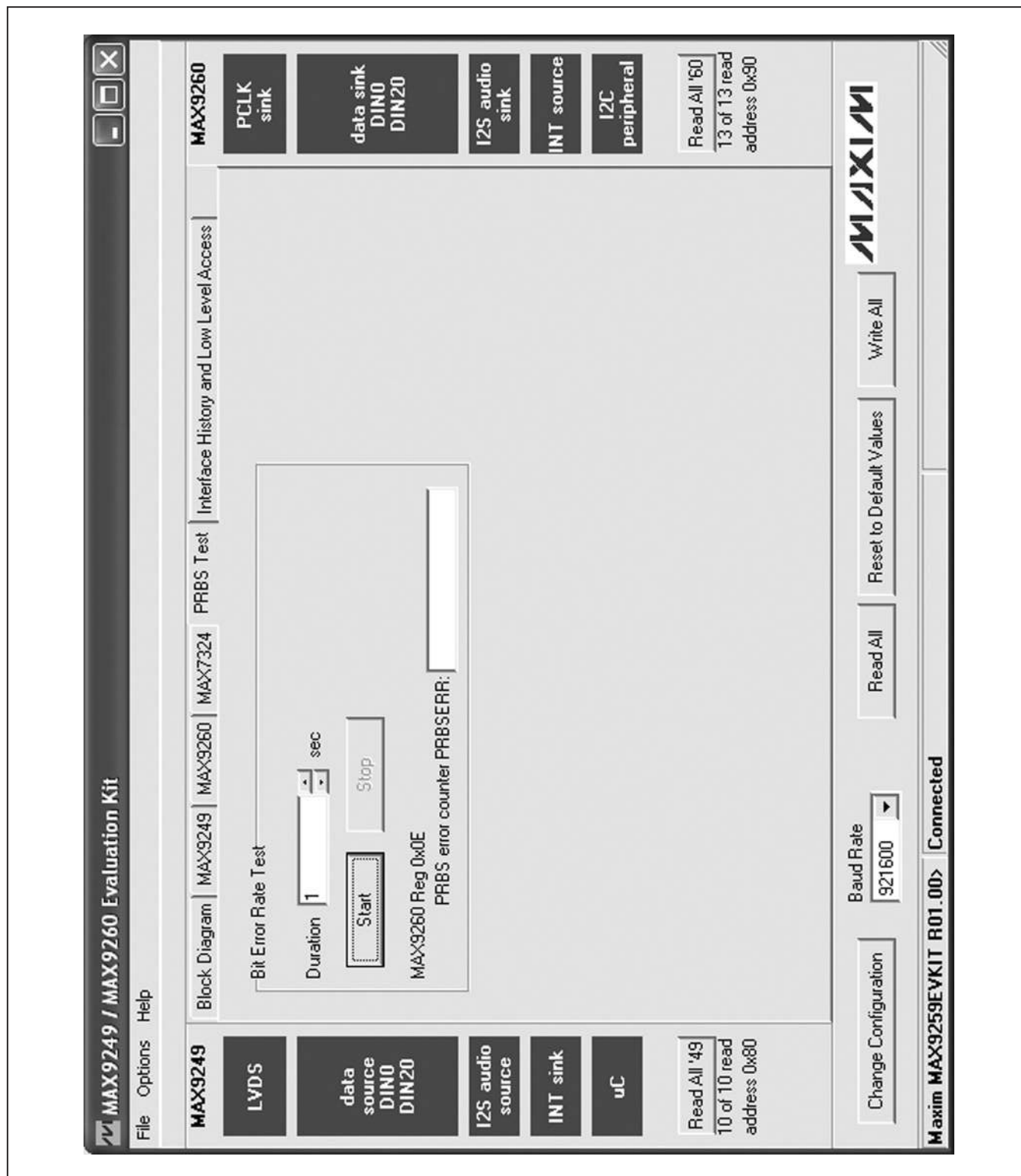

Figure 5. MAX9249/MAX9260 EV Kit Software Main Window (PRBS Test Tab)

MAX9249 Evaluation Kit

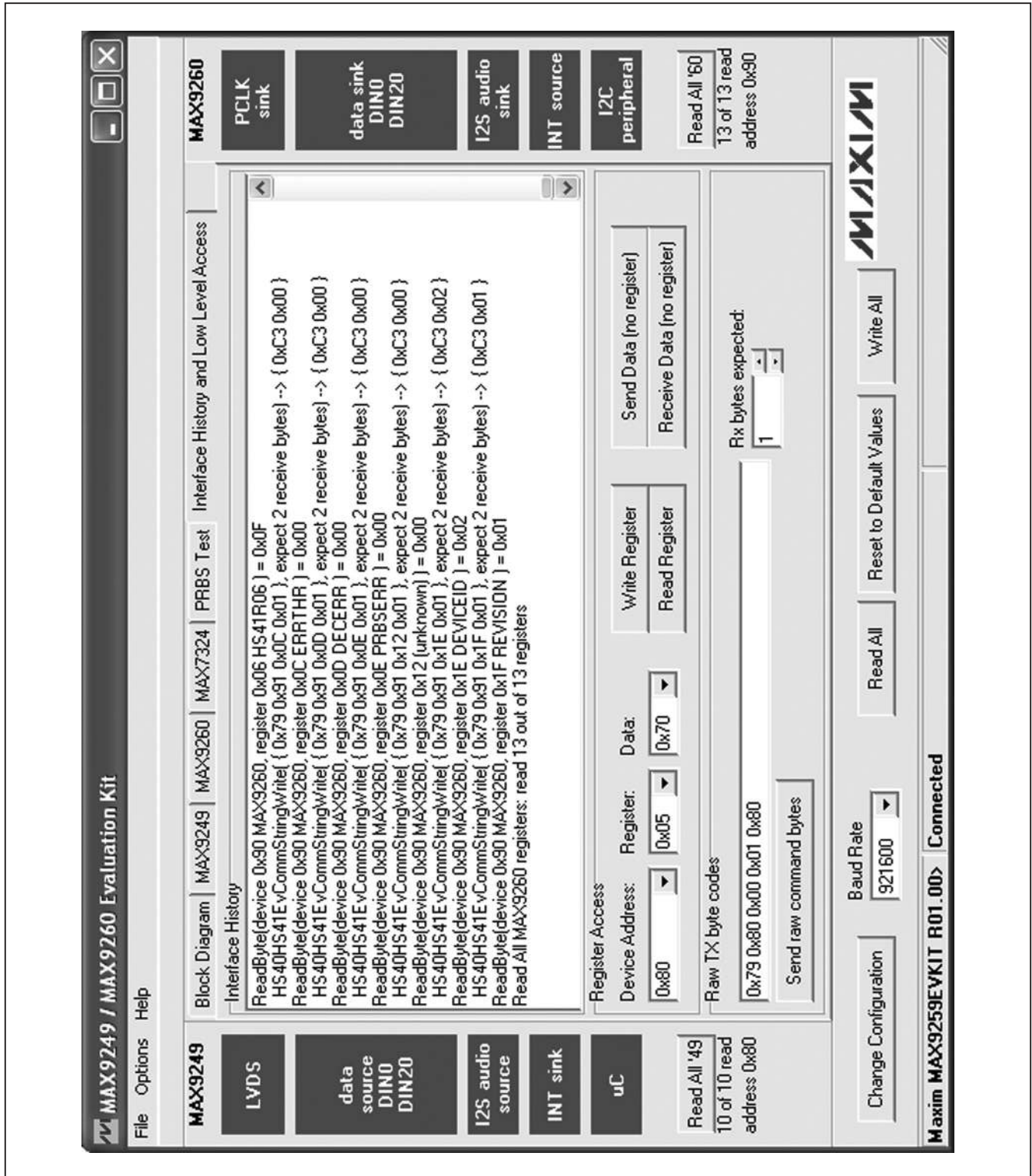

Figure 6. MAX9249/MAX9260 EV Kit Software Main Window (Interface History and Low Level Access Tab)

MAX9249 Evaluation Kit

Evaluates: **MAX9249**

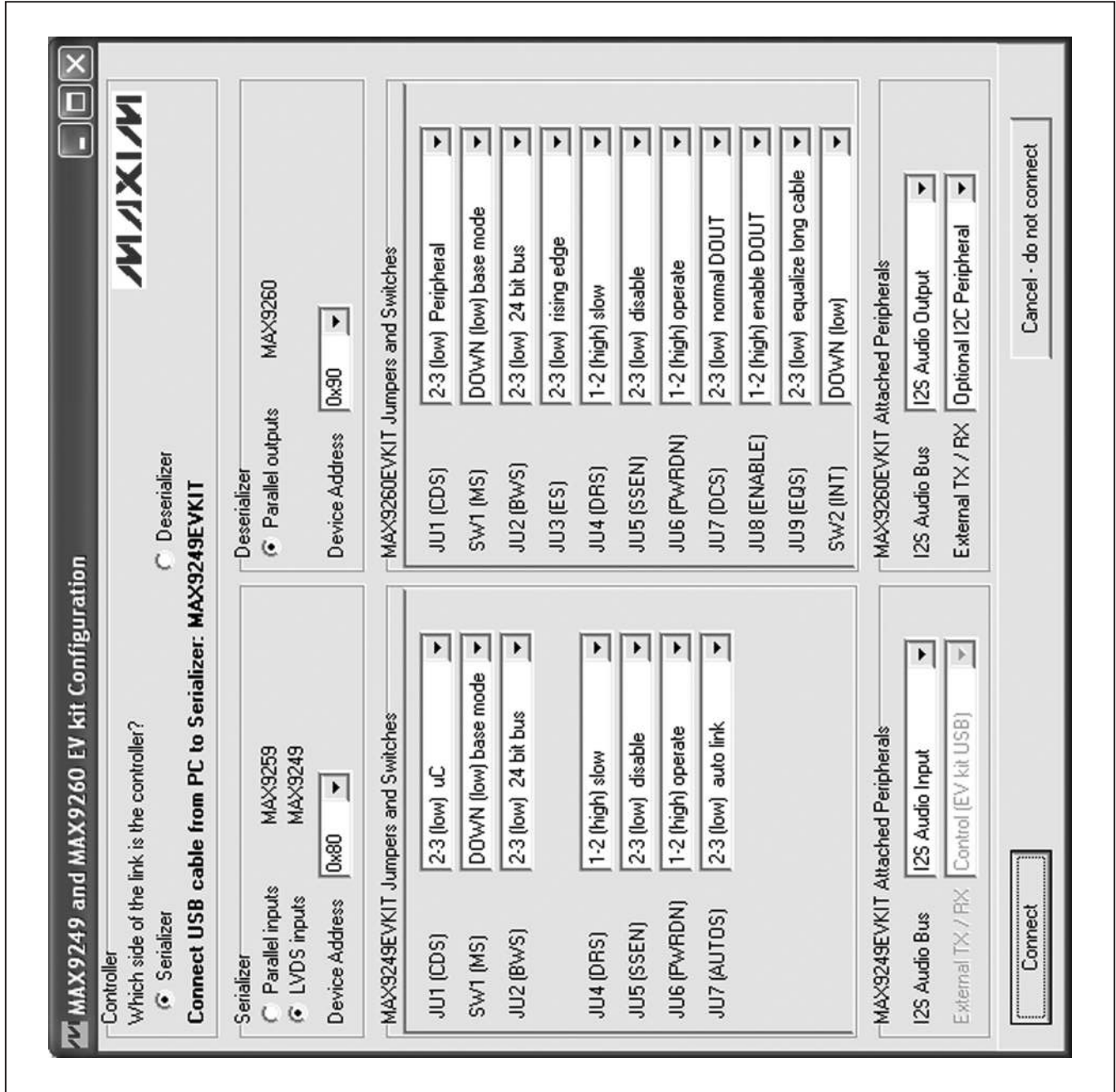

Figure 7. MAX9249/MAX9260 EV Kit Software Configuration Window

Evaluates: MAX9249

MAX9249 Evaluation Kit

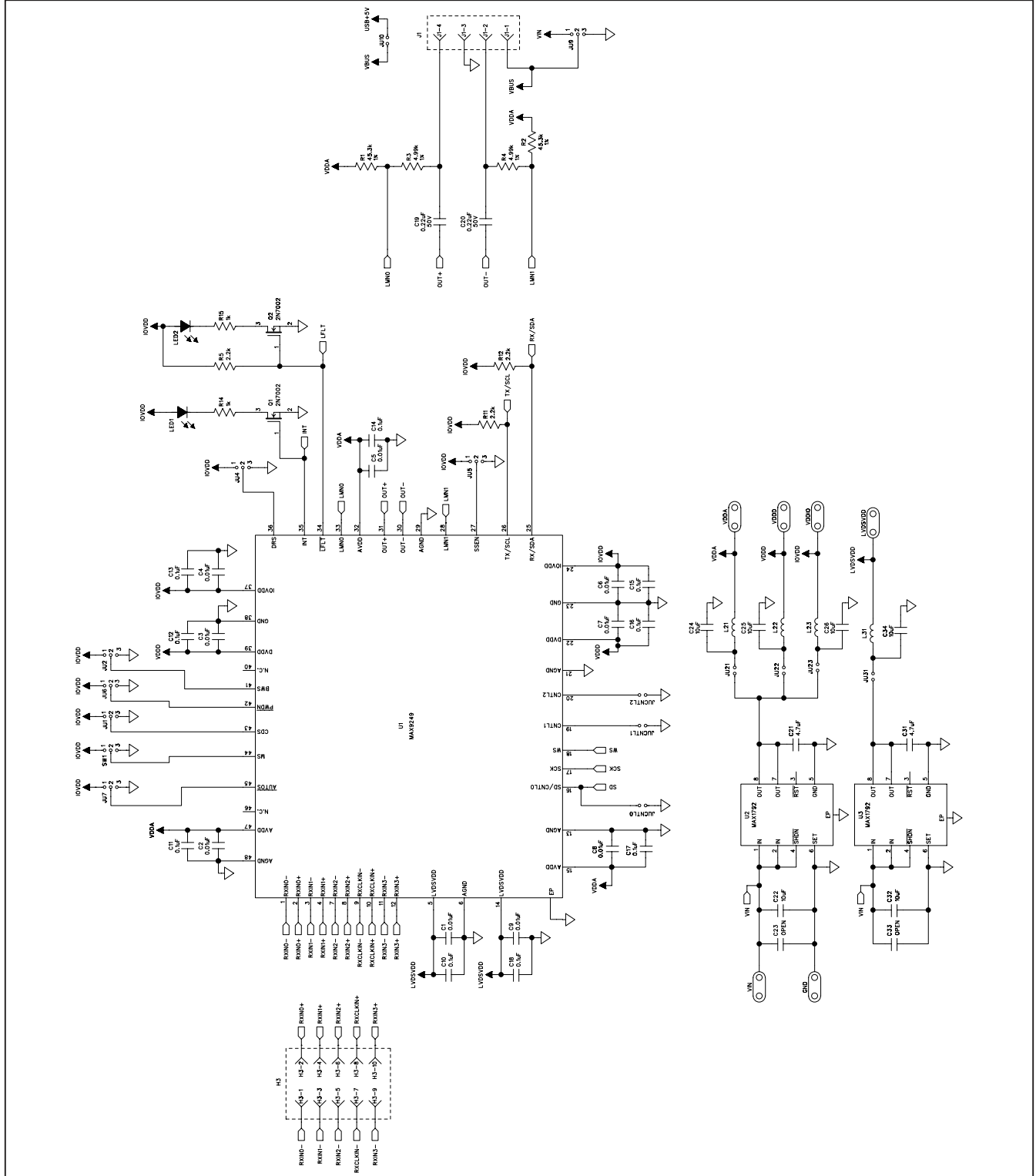

Figure 8a. MAX9249 EV Kit Schematic (Sheet 1 of 11)

MAX9249 Evaluation Kit

Evaluates: MAX9249

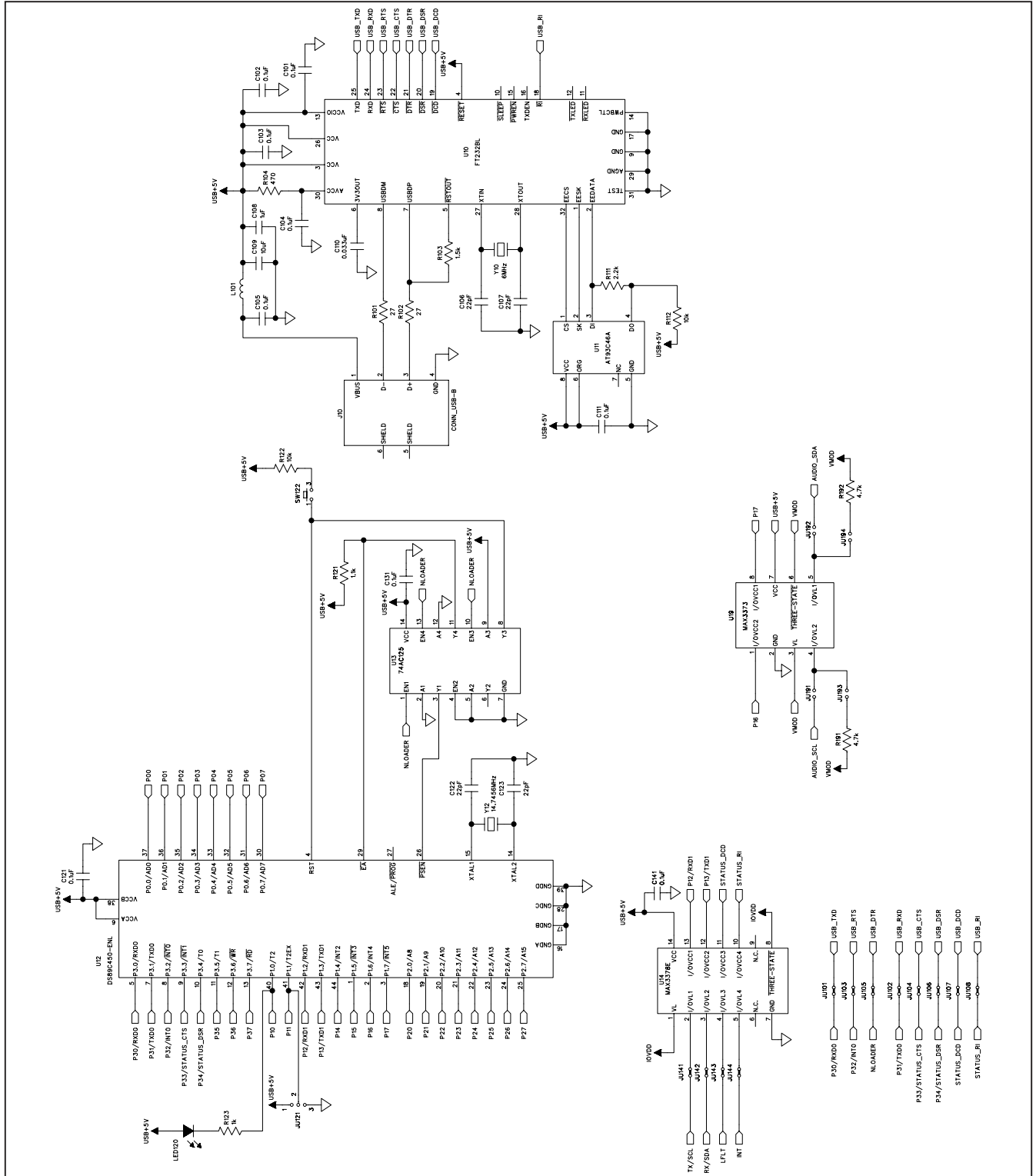

Figure 8b. MAX9249 EV Kit Schematic (Sheet 2 of 11)

MAX9249 Evaluation Kit

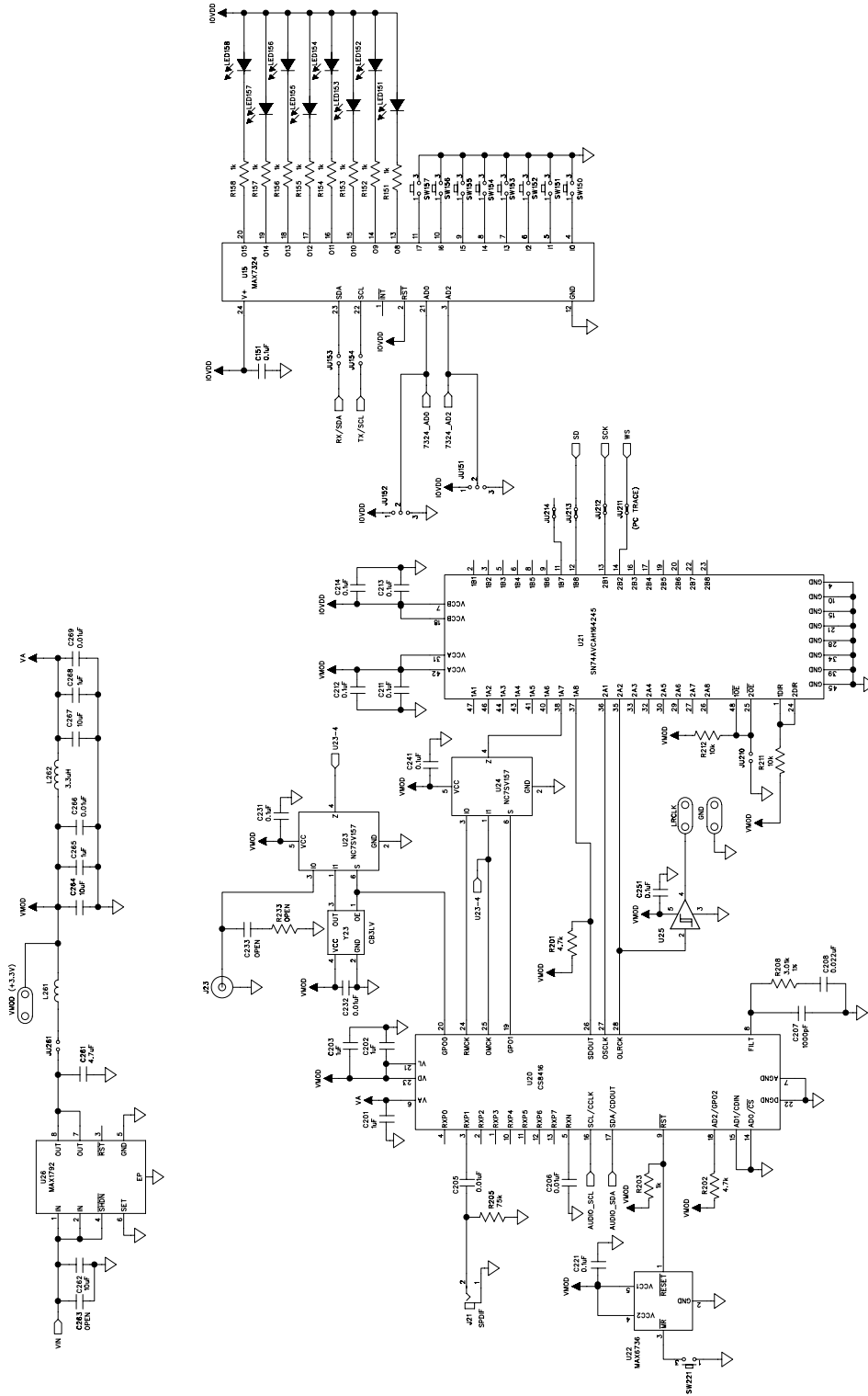

Figure 8c. MAX9249 EV Kit Schematic (Sheet 3 of 11)

MAX9249 Evaluation Kit

Evaluates: MAX9249

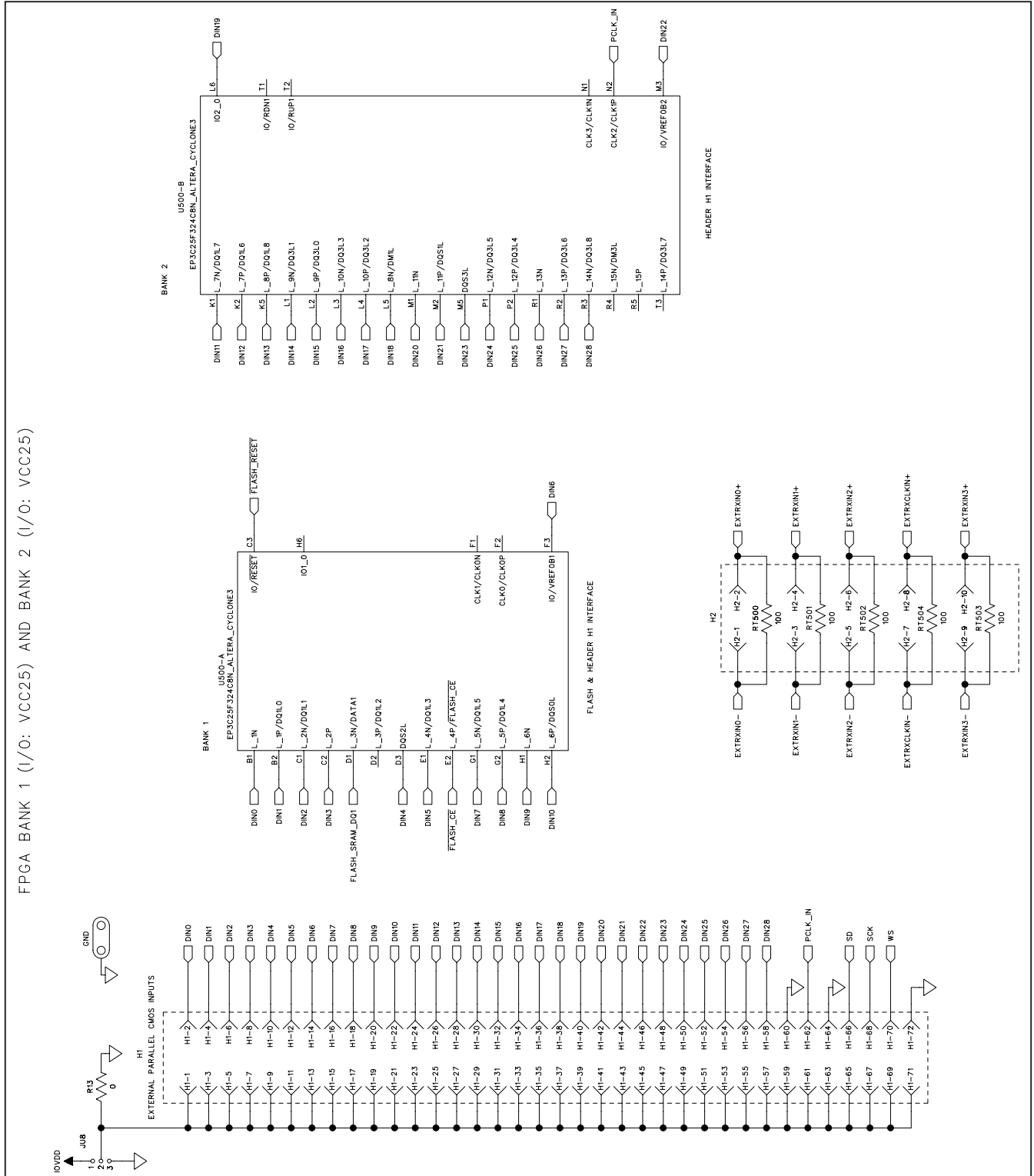

Figure 8d. MAX9249 EV Kit Schematic (Sheet 4 of 11)

MAX9249 Evaluation Kit

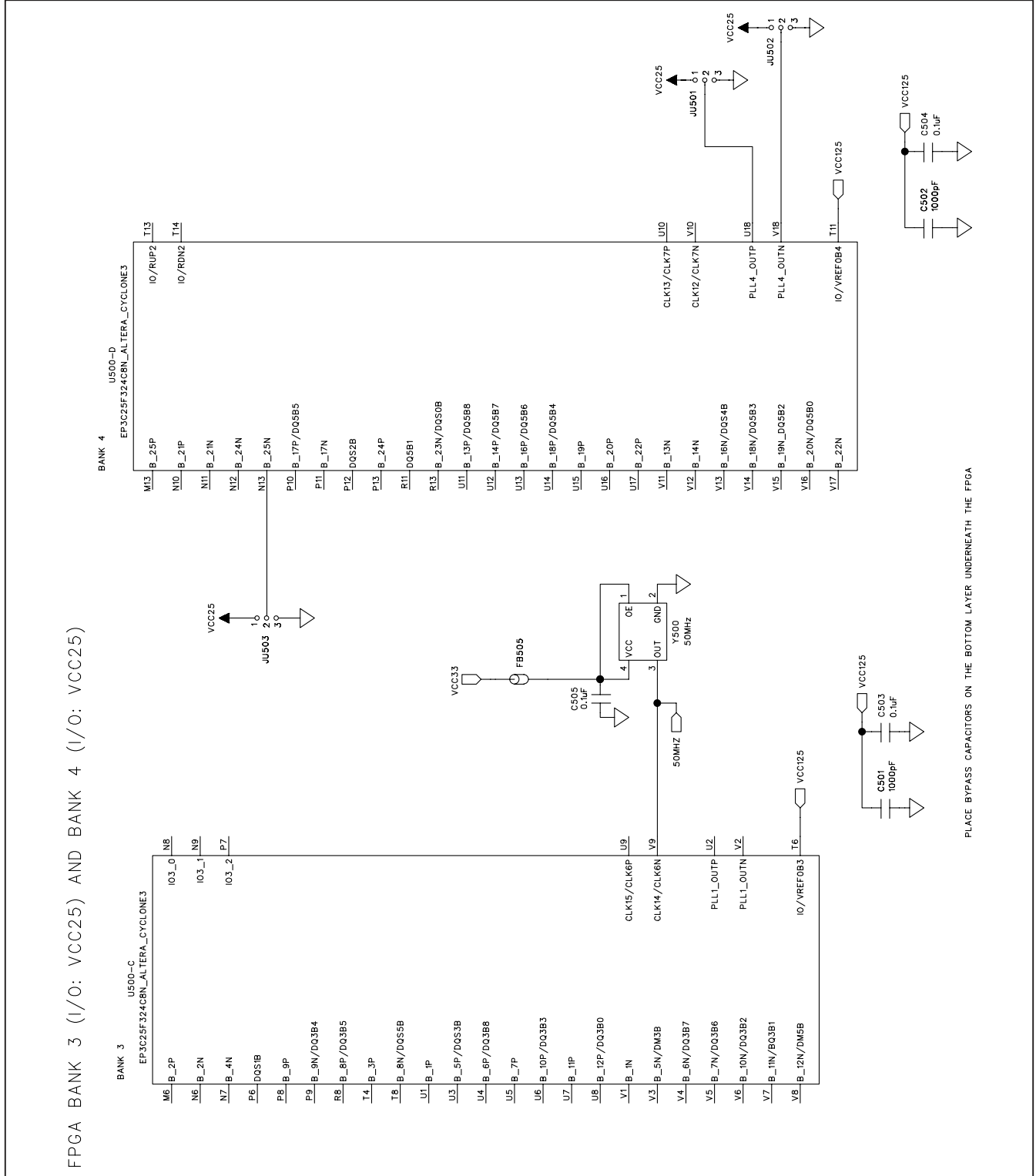

Figure 8e. MAX9249 EV Kit Schematic (Sheet 5 of 11)

MAX9249 Evaluation Kit

Evaluates: **MAX9249**

FPGA BANK 5 (I/O: VCC18) AND BANK 6 (I/O:VCC25)

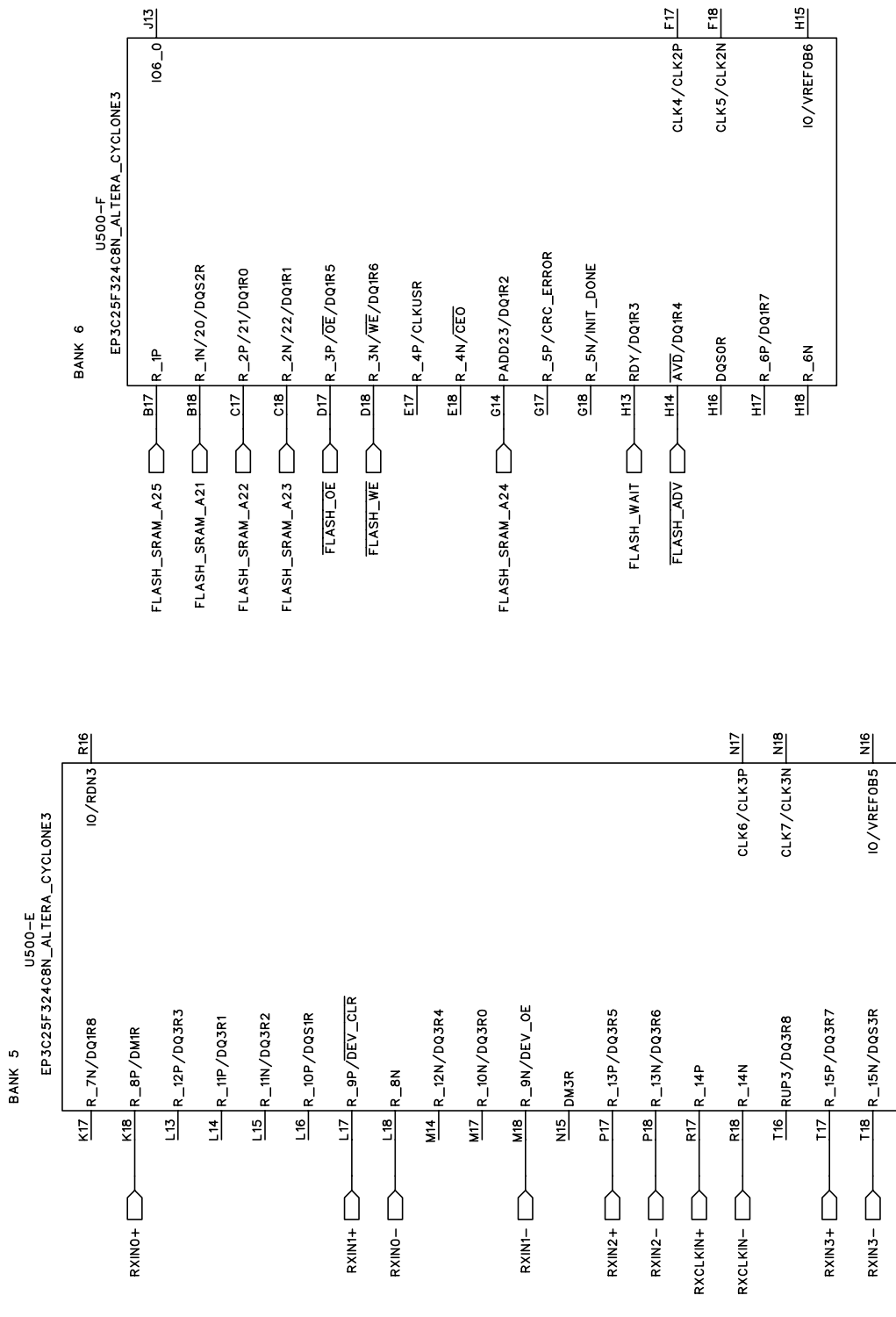

Figure 8f. MAX9249 EV Kit Schematic (Sheet 6 of 11)

Evaluates: MAX9249

MAX9249 Evaluation Kit

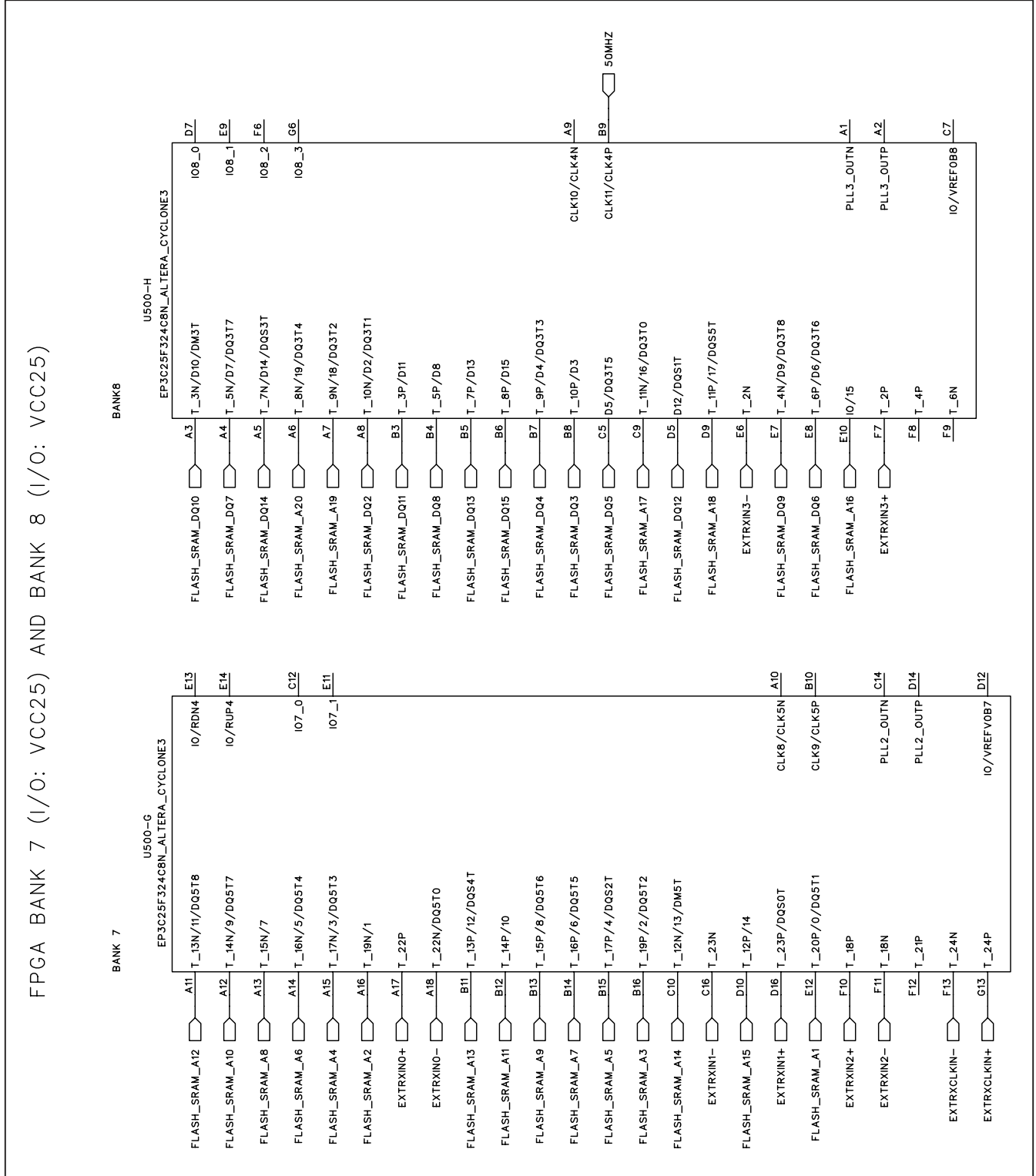
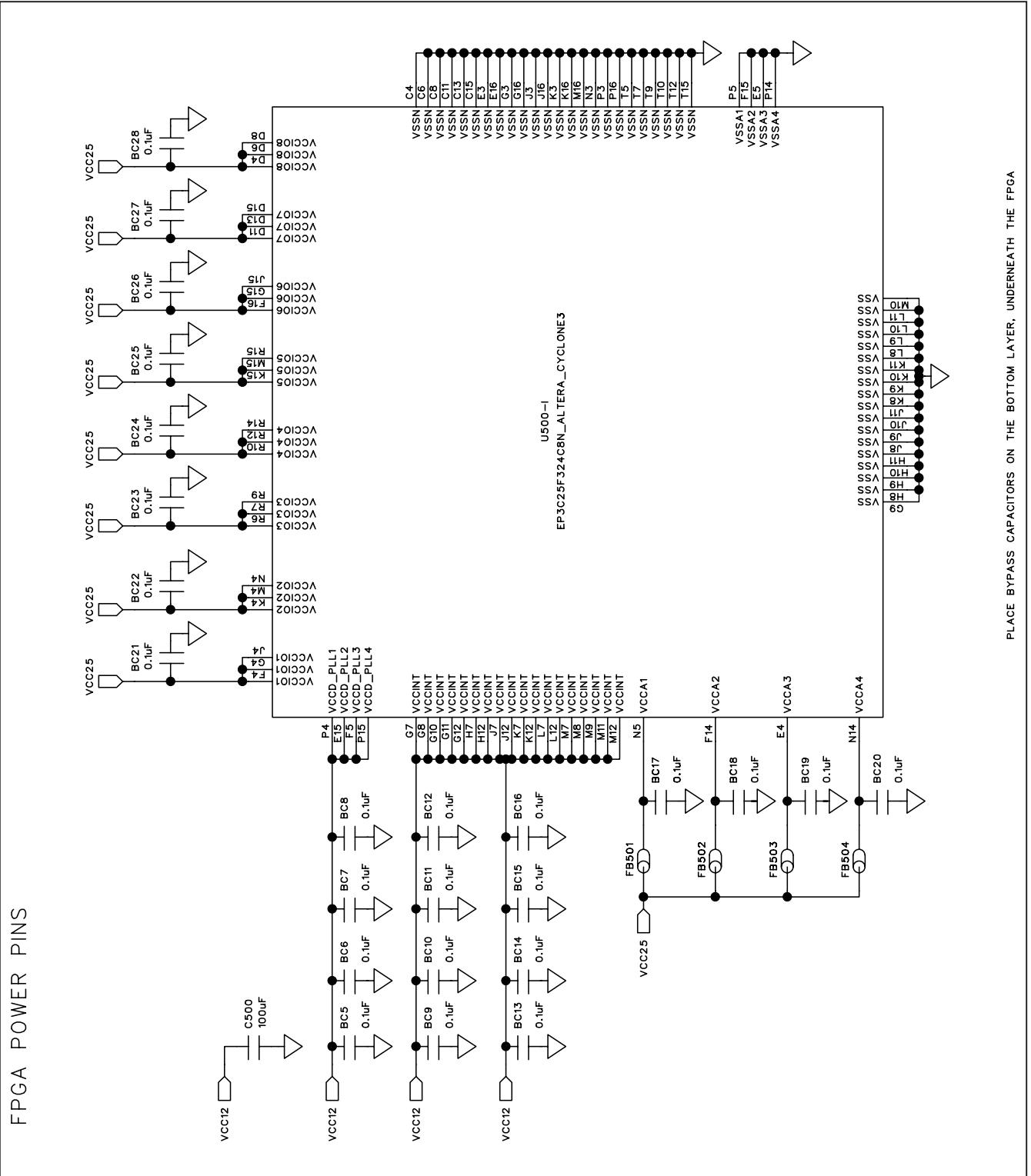

Figure 8g. MAX9249 EV Kit Schematic (Sheet 7 of 11)

MAX9249 Evaluation Kit



PLACE BYPASS CAPACITORS ON THE BOTTOM LAYER, UNDERNEATH THE FPGA

Evaluates: **MAX9249**

Figure 8h. MAX9249 EV Kit Schematic (Sheet 8 of 11)

MAX9249 Evaluation Kit

FPGA CONFIGURATION AND DEBUG

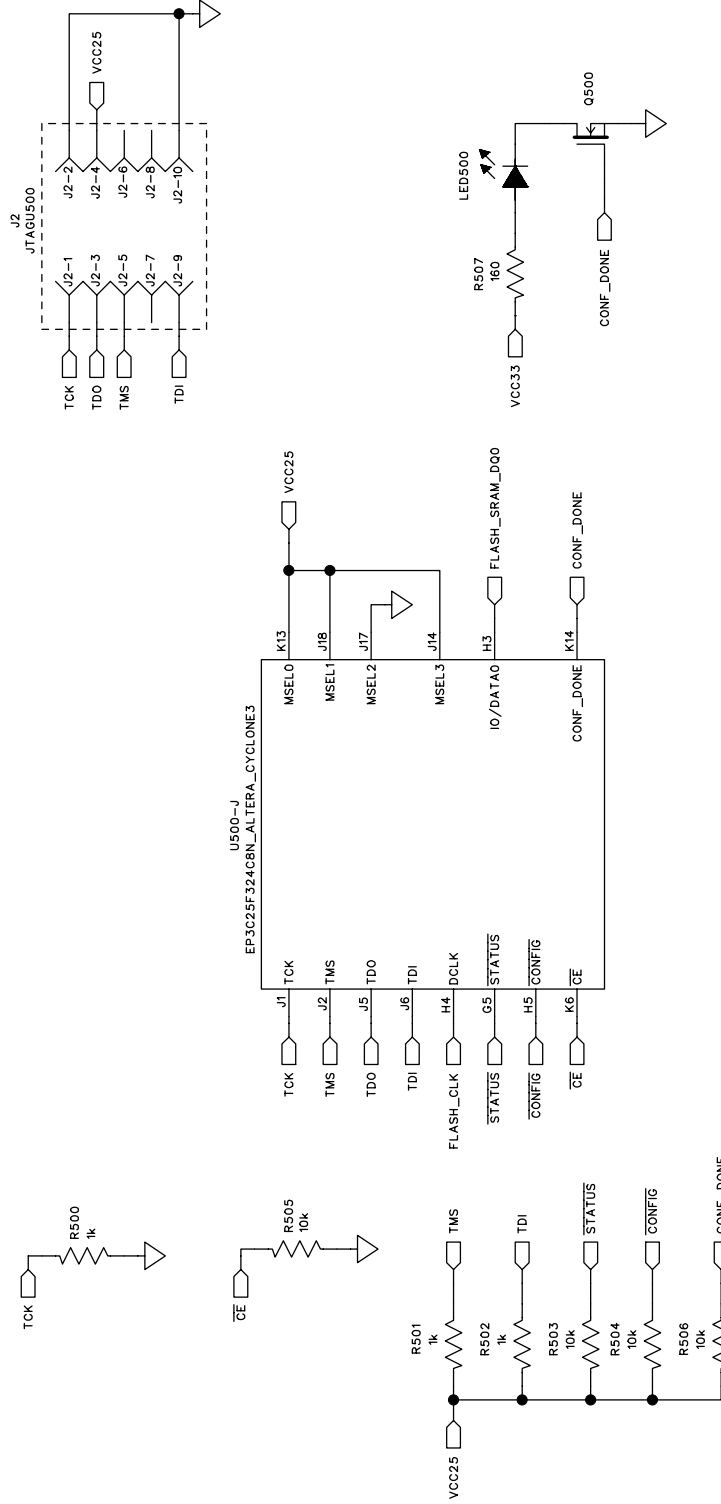

Figure 8i. MAX9249 EV Kit Schematic (Sheet 9 of 11)

MAX9249 Evaluation Kit

Evaluates: MAX9249

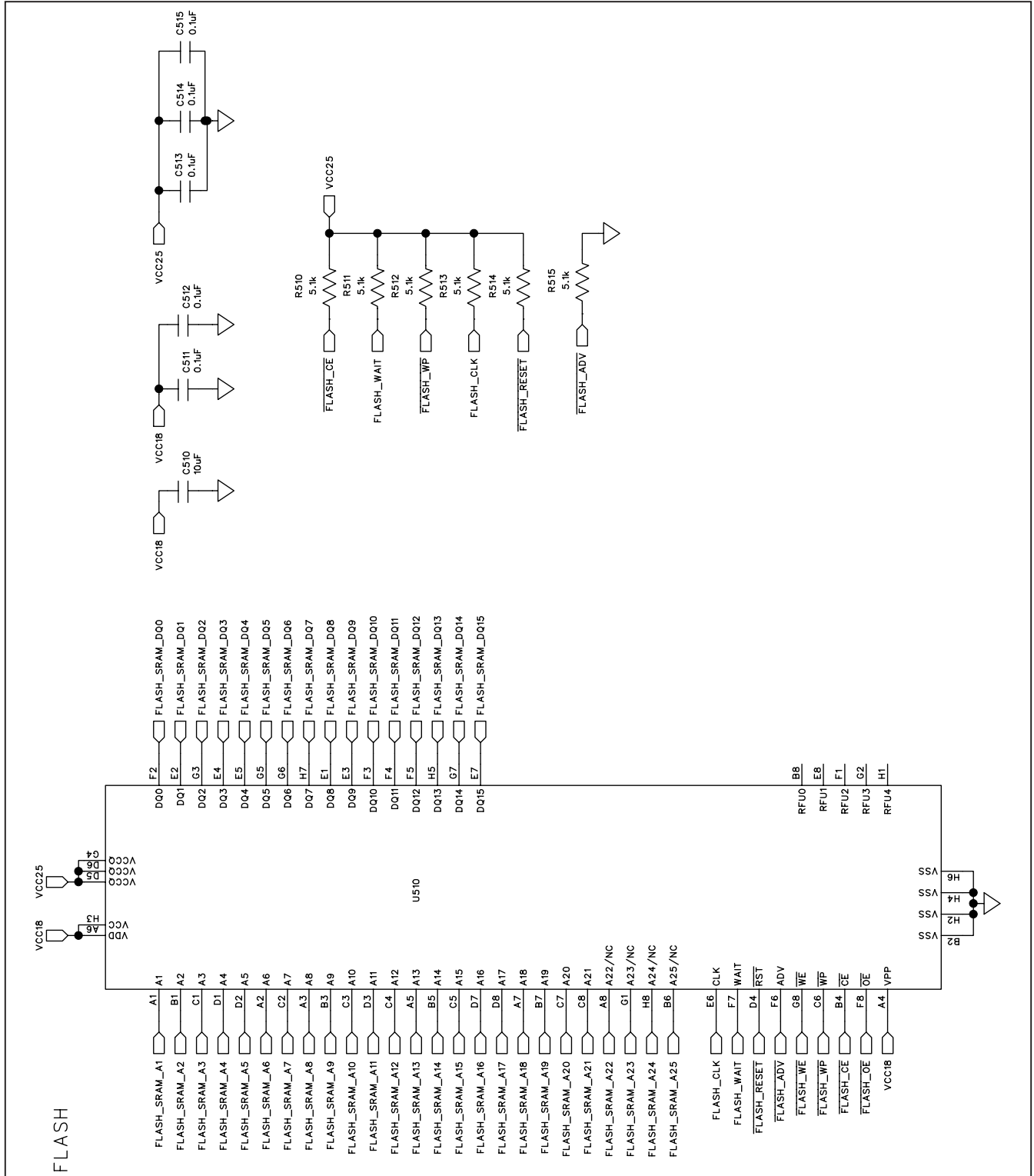

Figure 8j. MAX9249 EV Kit Schematic (Sheet 10 of 11)

MAX9249 Evaluation Kit

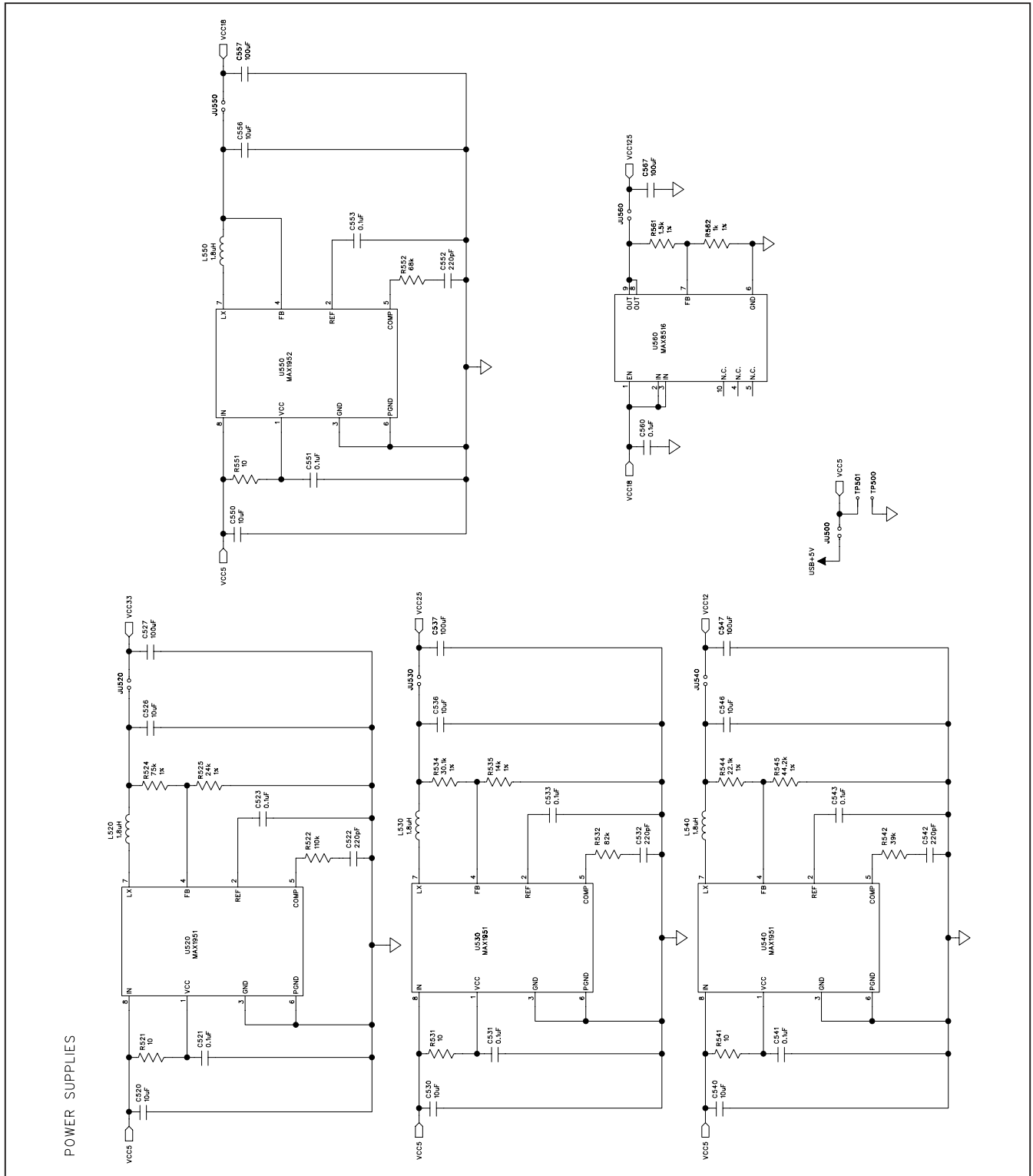

Figure 8k. MAX9249 EV Kit Schematic (Sheet 11 of 11)

MAX9249 Evaluation Kit

Evaluate: MAX9249

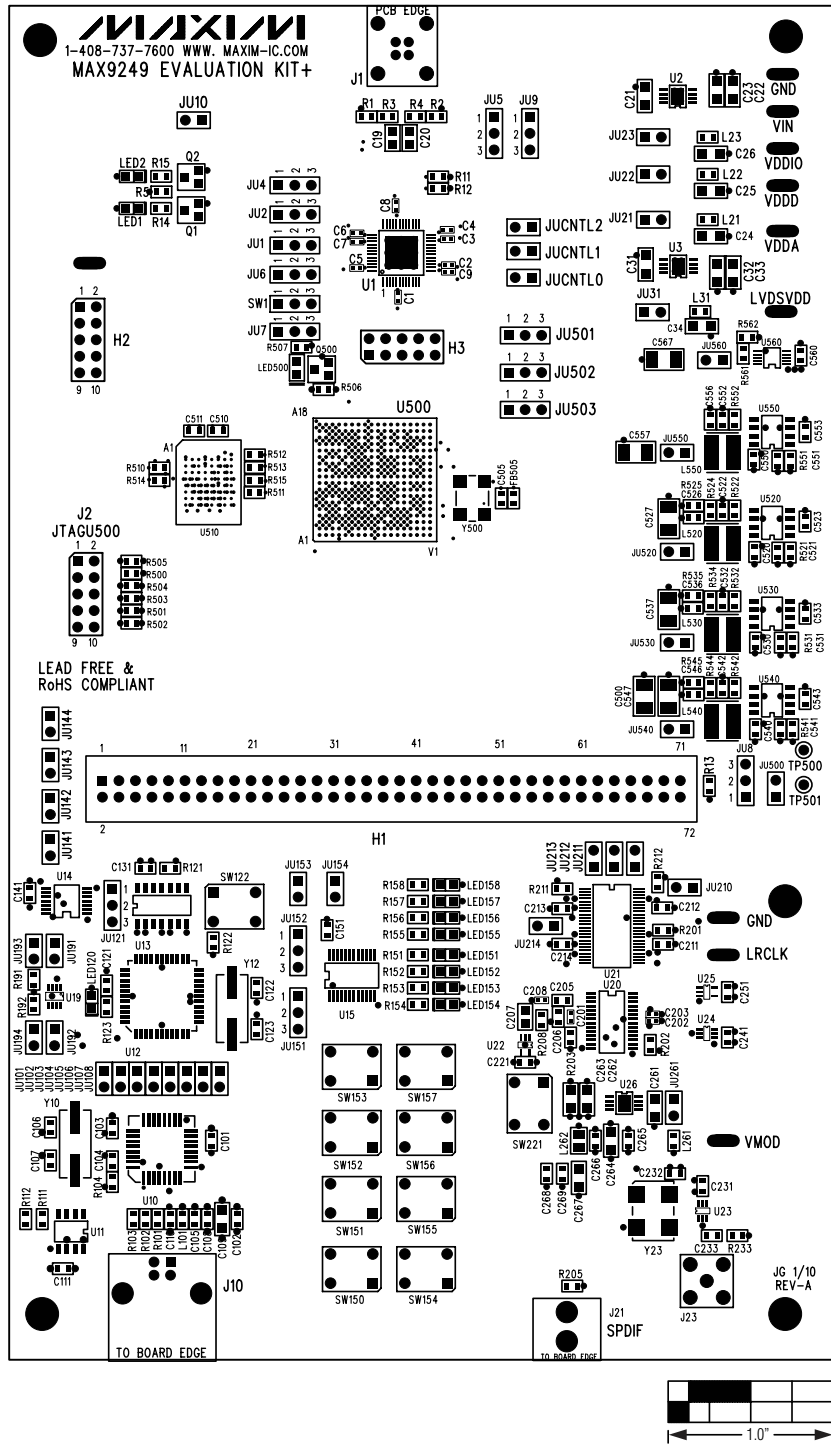

Figure 9. MAX9249 EV Kit Component Placement Guide—Component Side

MAX9249 Evaluation Kit

Evaluates: MAX9249

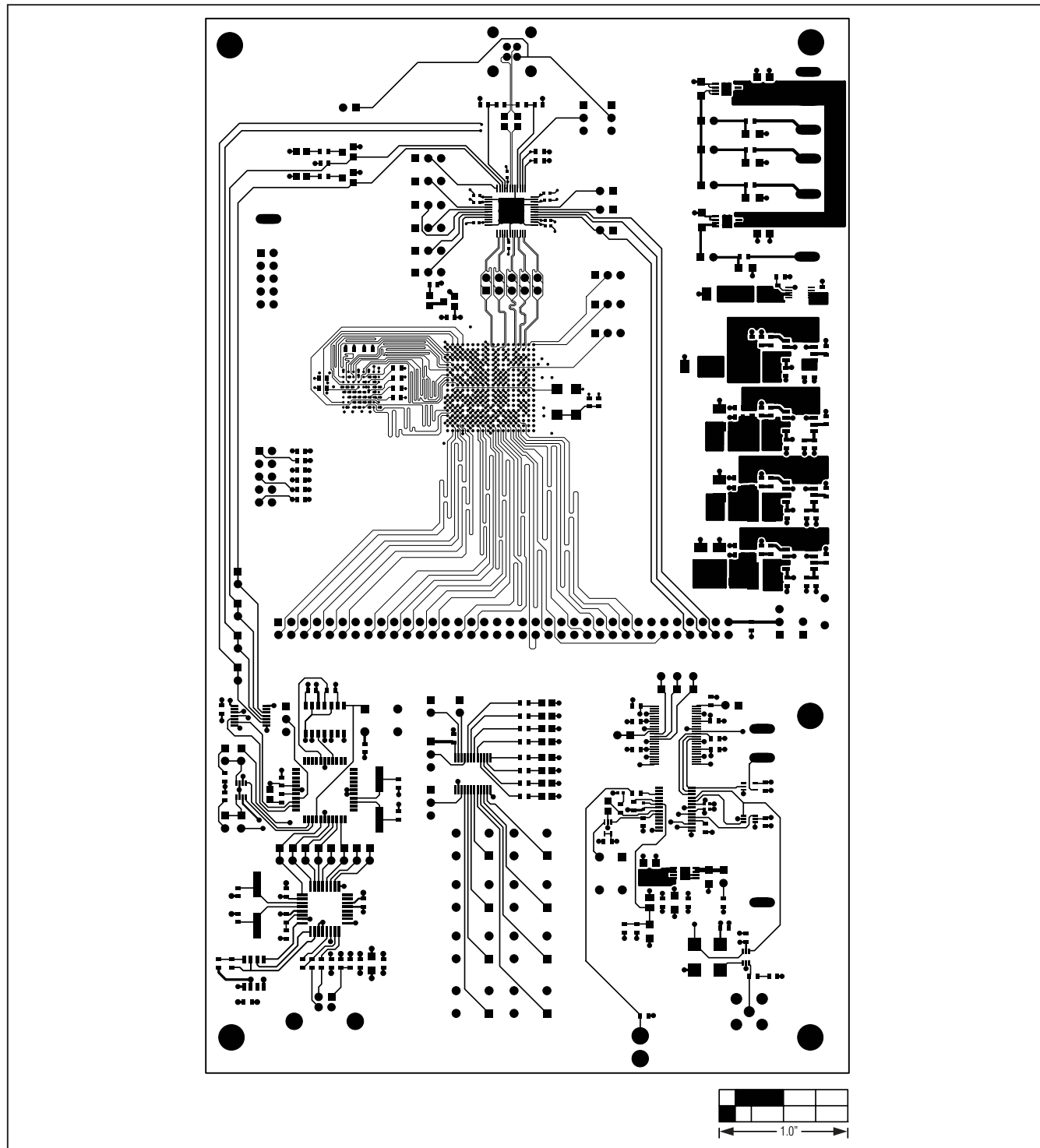

Figure 10. MAX9249 EV Kit PCB Layout—Component Side

MAX9249 Evaluation Kit

Evaluates: MAX9249

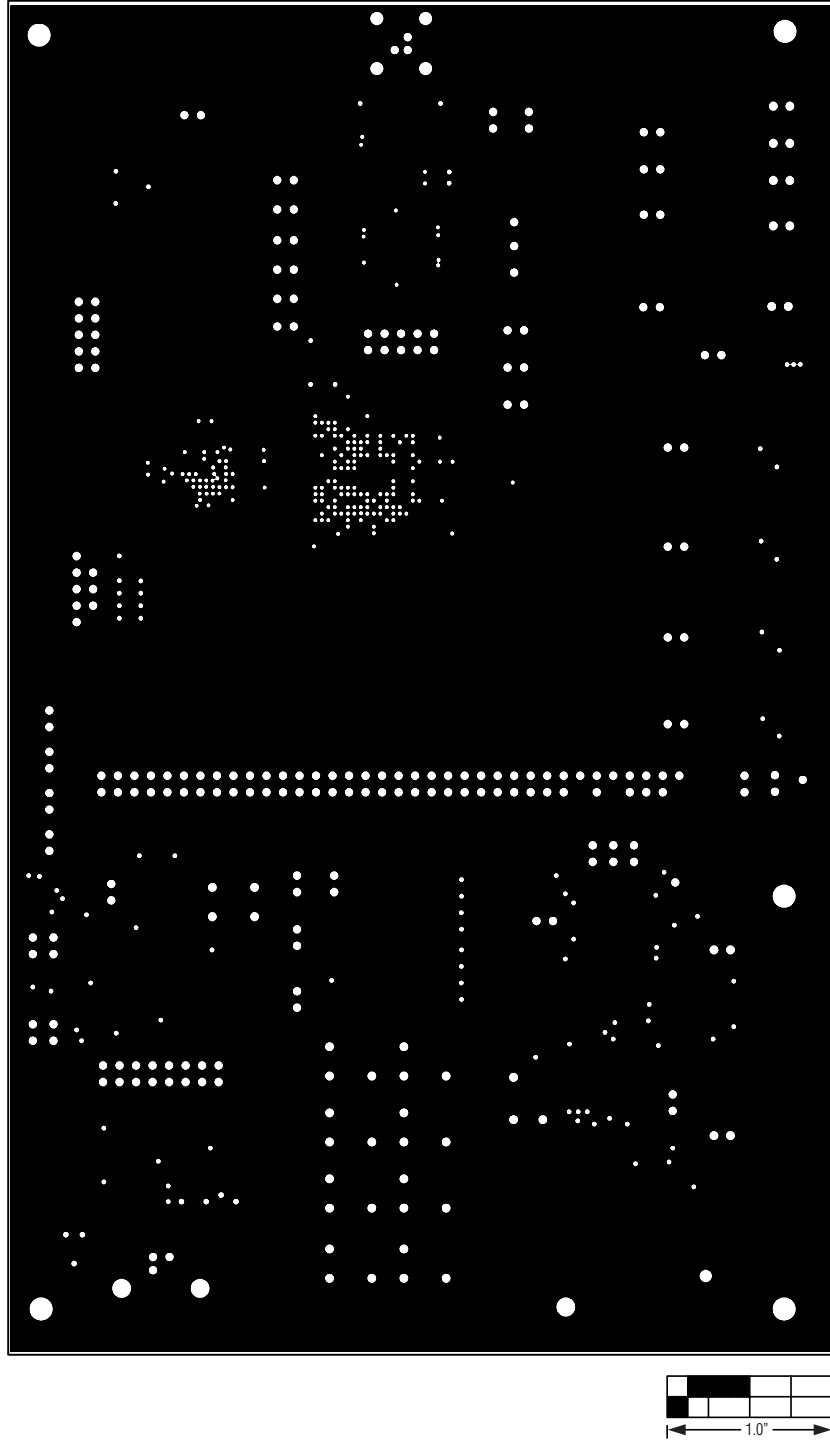

Figure 11. MAX9249 EV Kit PCB Layout—Ground Layer 2

MAX9249 Evaluation Kit

Evaluates: MAX9249

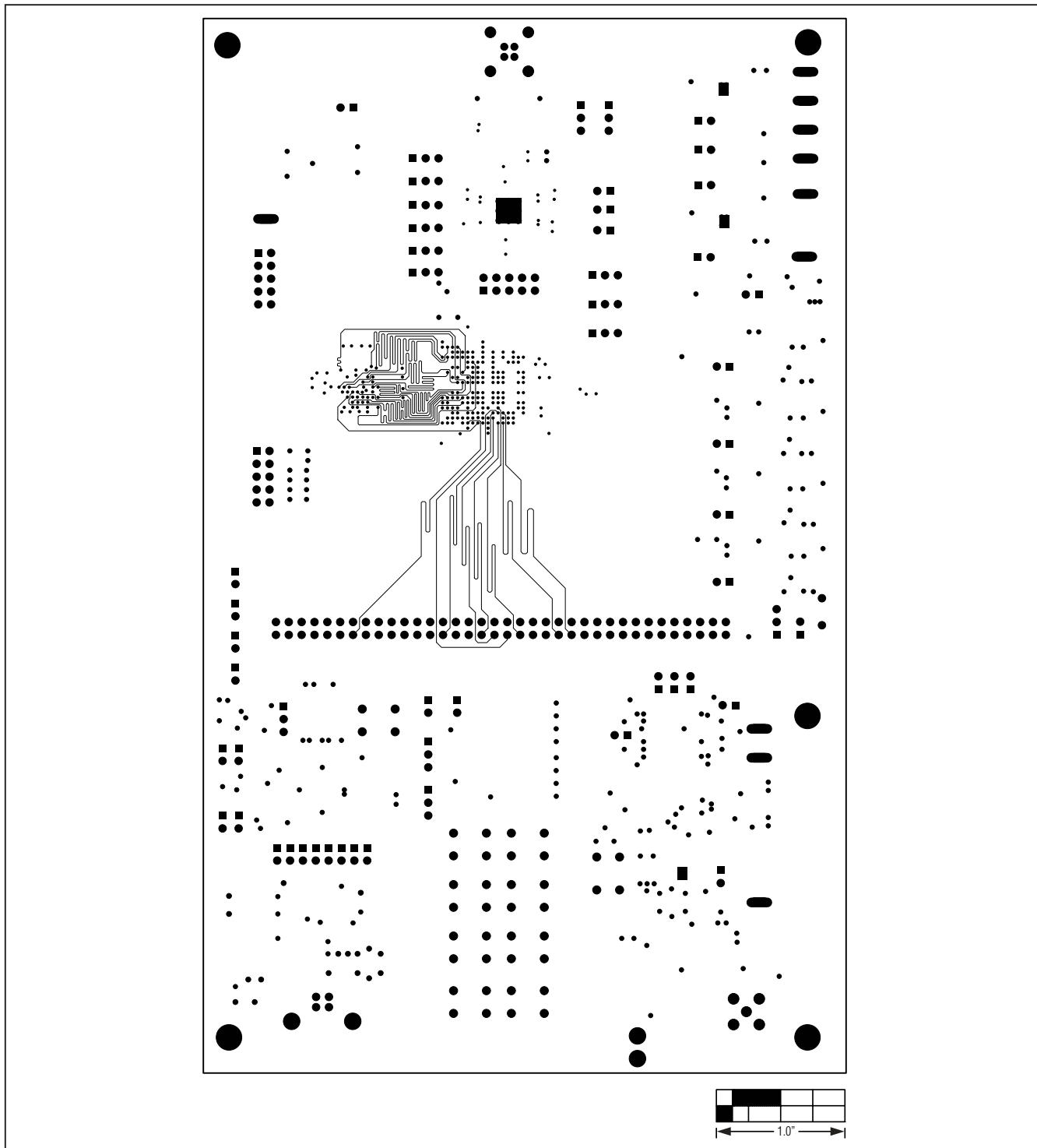

Figure 12. MAX9249 EV Kit PCB Layout—Signal Layer 3

MAX9249 Evaluation Kit

Evaluates: MAX9249

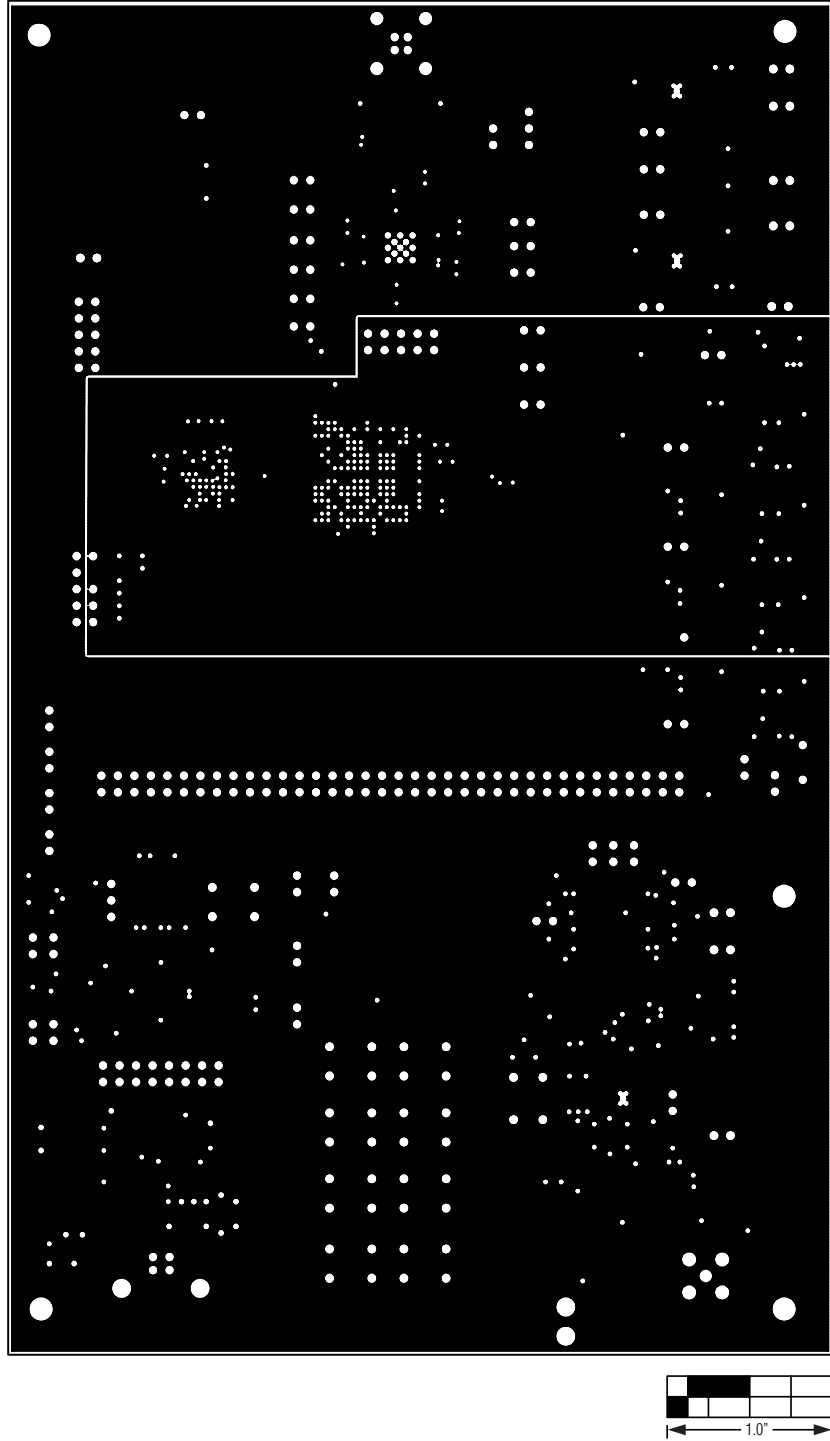

Figure 13. MAX9249 EV Kit PCB Layout—Power Layer 4

MAX9249 Evaluation Kit

Evaluates: MAX9249

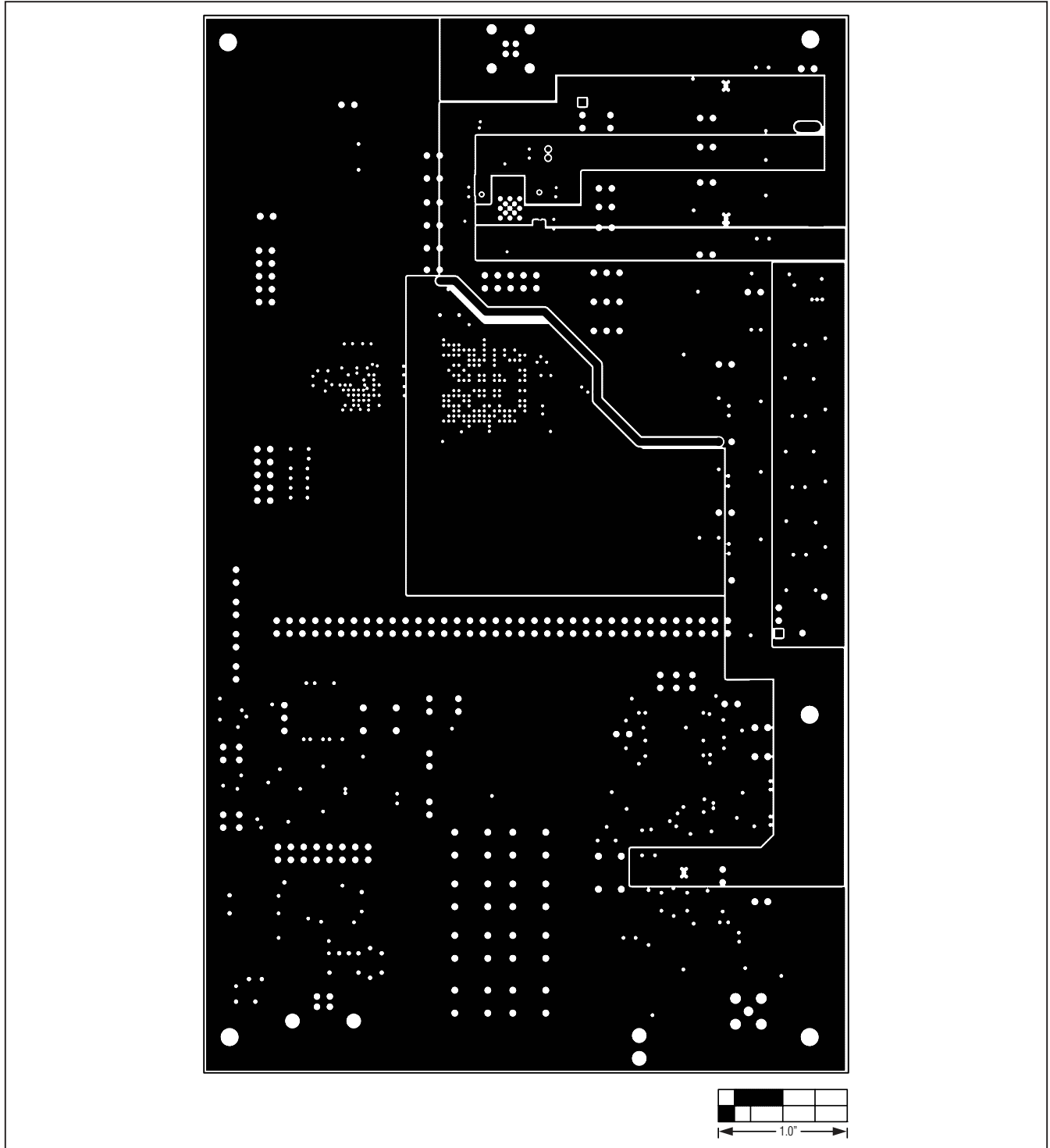

Figure 14. MAX9249 EV Kit PCB Layout—Power Layer 5

MAX9249 Evaluation Kit

Evaluates: MAX9249

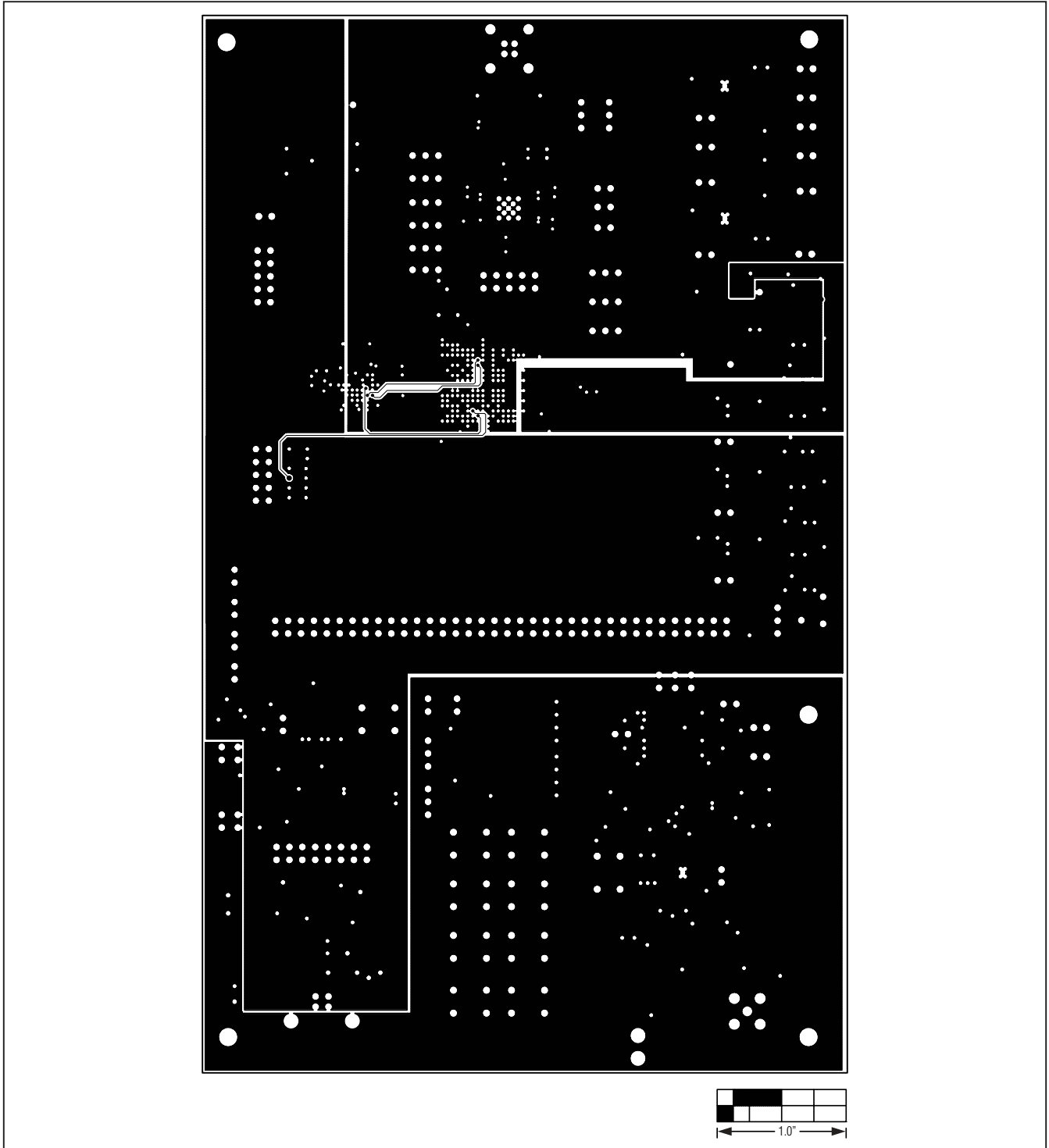

Figure 15. MAX9249 EV Kit PCB Layout—Power Layer 6

MAX9249 Evaluation Kit

Evaluates: MAX9249

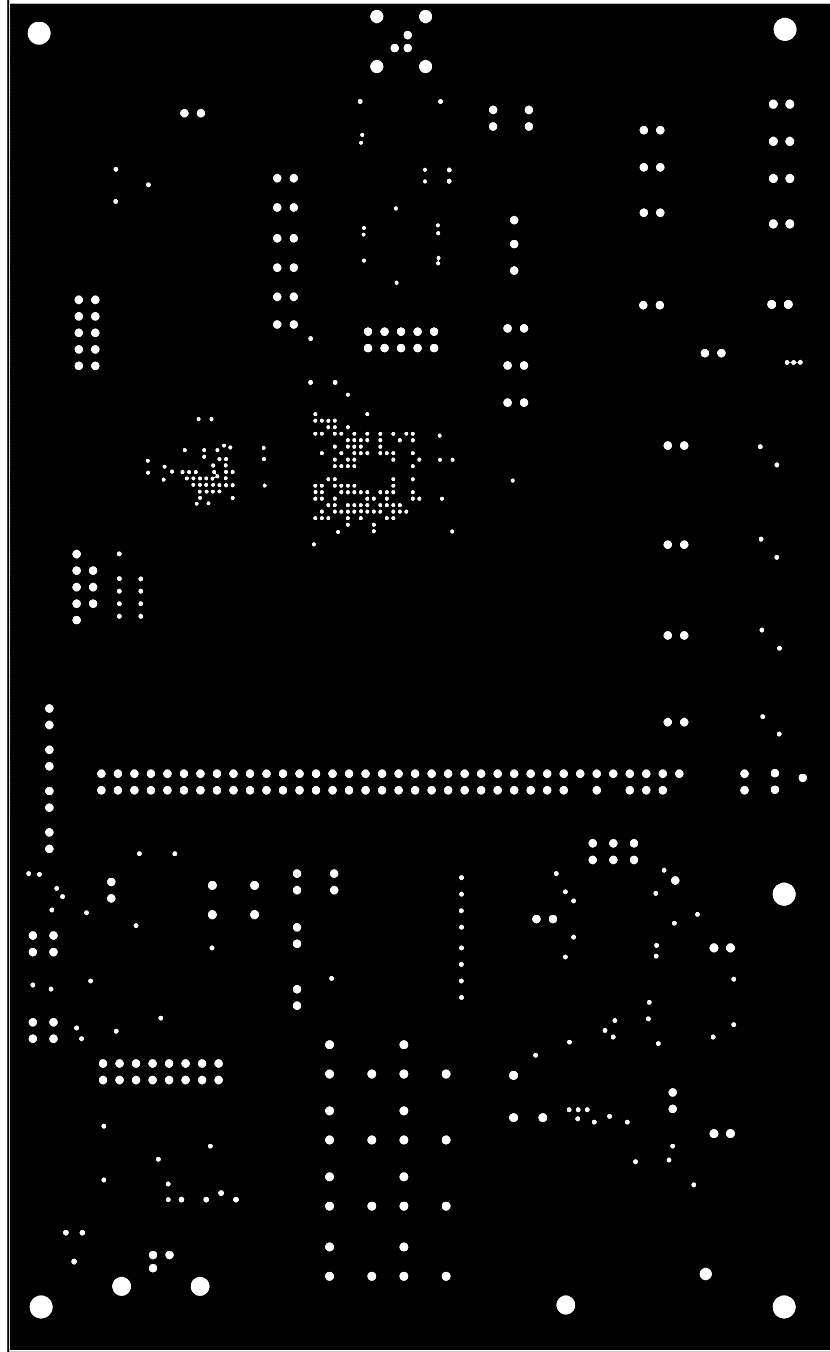

Figure 16. MAX9249 EV Kit PCB Layout—Ground Layer 7

MAX9249 Evaluation Kit

Evaluates: MAX9249

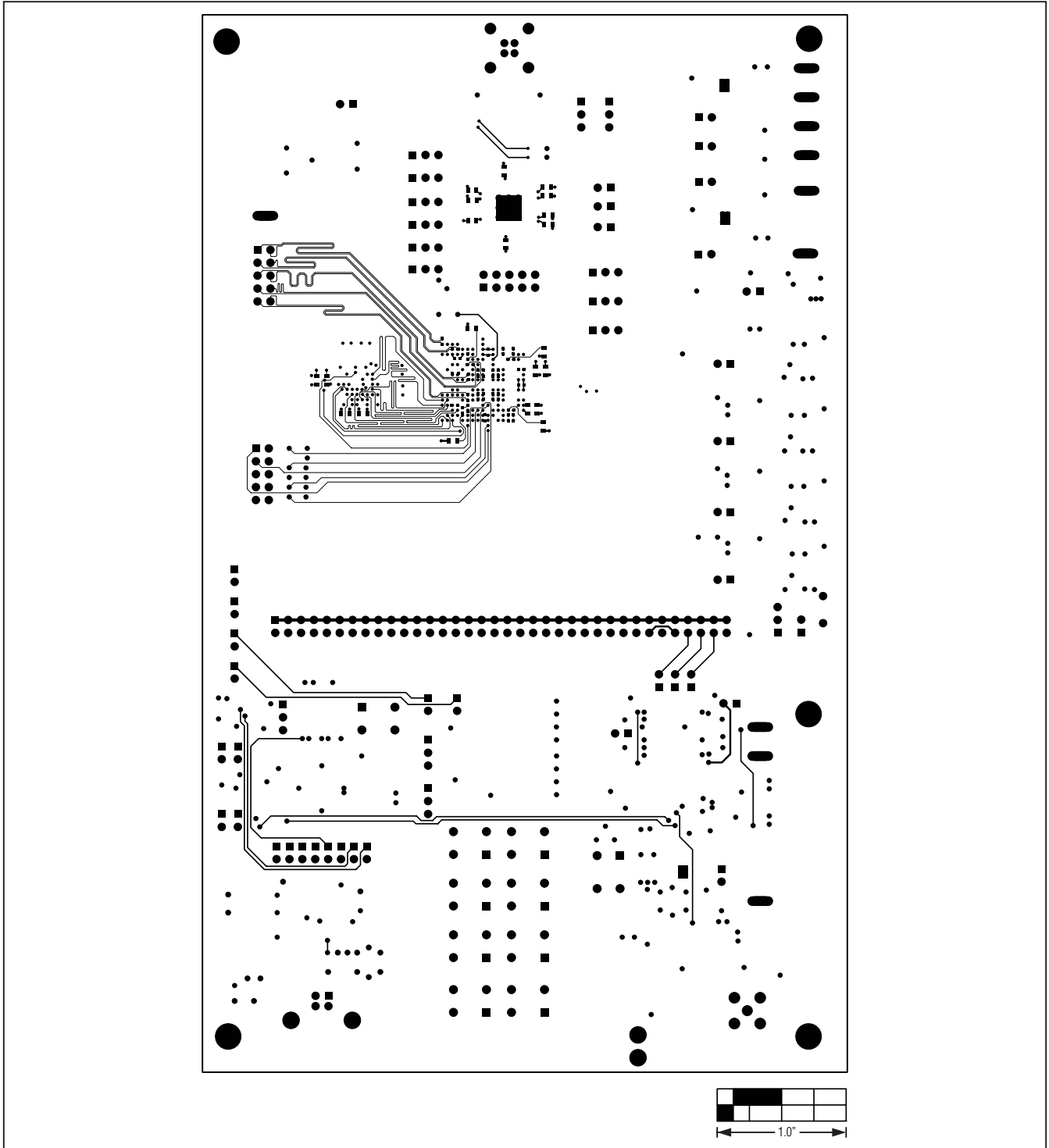

Figure 17. MAX9249 EV Kit PCB Layout—Solder Side

MAX9249 Evaluation Kit

Evaluates: MAX9249

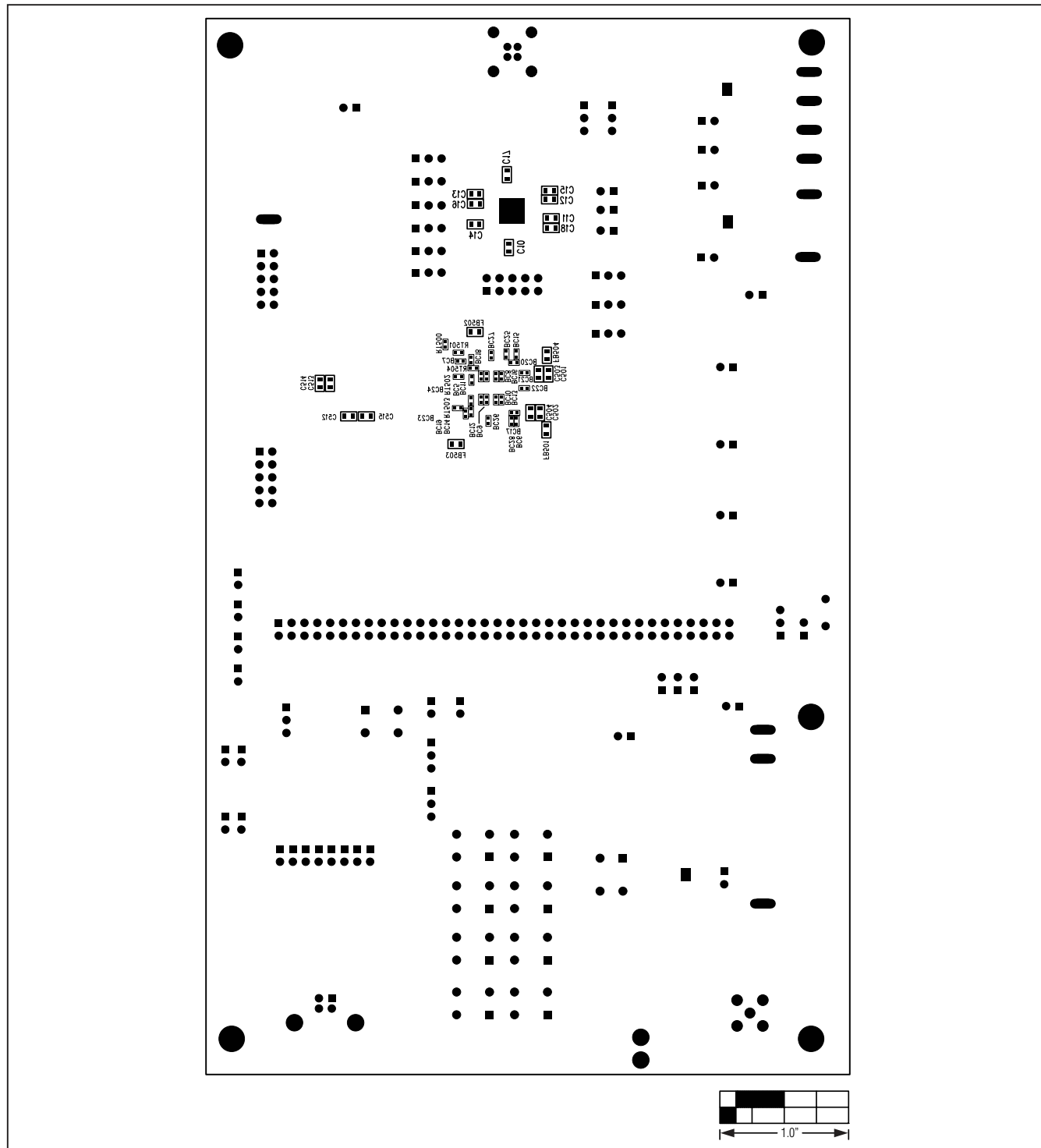

Figure 18. MAX9249 EV Kit Component Placement Guide—Solder Side

Maxim cannot assume responsibility for use of any circuitry other than circuitry entirely embodied in a Maxim product. No circuit patent licenses are implied. Maxim reserves the right to change the circuitry and specifications without notice at any time.

38 **Maxim Integrated Products, 120 San Gabriel Drive, Sunnyvale, CA 94086 408-737-7600**