

# Future Technology Devices International

## UMFT260EV1A Datasheet

### HID-class USB to UART/I<sup>2</sup>C Module

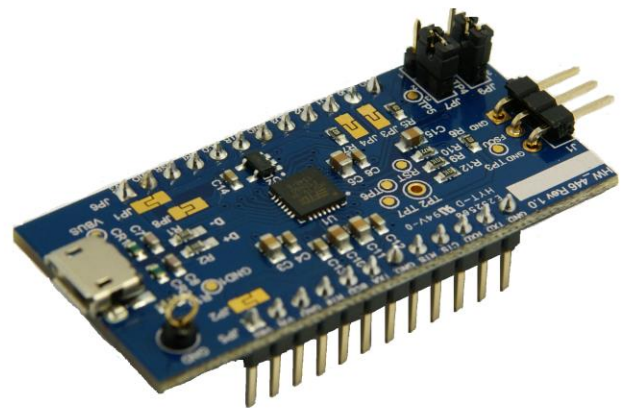

*UMFT260EV1A is an FT260 DIP development module.*

## 1 Introduction

The UMFT260EV1A is a development module for FTDI's FT260, HID-class USB to UART/I<sup>2</sup>C Bridge IC. The UMFT260EV1A is ideal for development purposes to quickly prove functionality of adding USB to a target design.

The UMFT260EV1A is a module which is designed to plug into a standard 0.8" wide 24 pin DIP socket. The USB connection to a host system is via a Micro USB-B connector.

All components used, including the FT260 are Pb-free (RoHS compliant).

### 1.1 Features

The UMFT260EV1A is built with a FT260; many of the features of the FT260 can be utilized with this module. For further details of FT260 features, please refer to the FT260 datasheet, DS\_FT260, is available at <http://www.ftdichip.com/FT260>.

In addition to the features listed in the FT260 datasheet, the UMFT260EV1A has the following features:

- PCB assembly module is designed to fit a standard 20.32mm (0.8") wide 24 pin DIP socket. Pins are on a 2.54mm (0.1") pitch.
- An on-board Micro USB-B type connector allows modules to be connected to a host system via a standard USB A to Micro B cable.
- On-board I<sup>2</sup>C 2kbits EEPROM (address:0x50) to contain FT260 configuration settings and vendor specific parameters (I<sup>2</sup>C pull-high circuit is implemented as default)
- Jumpers for selecting the FT260 HID interfaces configuration
- Solder jumpers for configuring the FT260Q to be in USB Bus powered or Self powered modes.

Neither the whole nor any part of the information contained in, or the product described in this manual, may be adapted or reproduced in any material or electronic form without the prior written consent of the copyright holder. This product and its documentation are supplied on an as-is basis and no warranty as to their suitability for any particular purpose is either made or implied. Future Technology Devices International Ltd will not accept any claim for damages howsoever arising as a result of use or failure of this product. Your statutory rights are not affected. This product or any variant of it is not intended for use in any medical appliance, device or system in which the failure of the product might reasonably be expected to result in personal injury. This document provides preliminary information that may be subject to change without notice. No freedom to use patents or other intellectual property rights is implied by the publication of this document. Future Technology Devices International Ltd, Unit 1, 2 Seaward Place, Centurion Business Park, Glasgow G41 1HH United Kingdom. Scotland Registered Company Number: SC136640

## **Table of Contents**

<b>1</b>	<b>Introduction .....</b>	<b>1</b>
1.1	Features .....	1
<b>2</b>	<b>Driver Support .....</b>	<b>3</b>
<b>3</b>	<b>Ordering Information .....</b>	<b>4</b>
<b>4</b>	<b>UMFT260EV1A Signals.....</b>	<b>5</b>
4.1	UMFT260EV1A Pin Out.....	5
4.2	JP1/JP5/JP6 Signal Descriptions .....	6
4.3	Jumper Descriptions .....	8
<b>5</b>	<b>Module Configurations .....</b>	<b>9</b>
5.1	<b>Power Configuration .....</b>	<b>9</b>
A.	Bus Powered Configuration .....	9
B.	Self Powered configuration .....	9
5.2	<b>I/O Voltage Level Configuration .....</b>	<b>10</b>
A.	Internal Regulator(3.3V) Configuration .....	10
B.	External Power Source Configuration .....	10
5.3	<b>I<sup>2</sup>C Bus Pull-up Configuration .....</b>	<b>11</b>
5.4	<b>On-board I<sup>2</sup>C EEPROM Configuration.....</b>	<b>11</b>
5.5	<b>Programming the FT260 On-Chip eFUSE.....</b>	<b>11</b>
5.6	Power consumption.....	12
<b>6</b>	<b>Module Dimensions.....</b>	<b>13</b>
<b>7</b>	<b>UMFT260EV1A Module Circuit Schematic.....</b>	<b>14</b>
<b>8</b>	<b>Contact Information.....</b>	<b>15</b>
	<b>Appendix A – References .....</b>	<b>14</b>
	Document References .....	14
	Acronyms and Abbreviations .....	14
	<b>Appendix B – List of Figures and Tables.....</b>	<b>15</b>
	List of Figures .....	15
	List of Tables .....	15
	<b>Appendix C – Revision History.....</b>	<b>16</b>

## 2 Driver Support

Standard Human Interface Device (HID) Driver support for the FT260 USB Device is available from the following OS:

- Windows 10 32,64-bit
- Windows 8.1 32,64-bit
- Windows 8 32,64-bit
- Windows 7 32,64-bit
- Windows Vista and Vista 64-bit
- Windows XP and XP 64-bit
- Windows Server 2008, 2003, 2000
- Windows Embedded Operating Systems
- Mac OS X
- Linux

### **3 Ordering Information**

<b>Module Code</b>	<b>Utilised IC Code</b>	<b>Description</b>
UMFT260EV1A	FT260Q	FT260Q Development module.

## 4 UMFT260EV1A Signals

### 4.1 UMFT260EV1A Pin Out

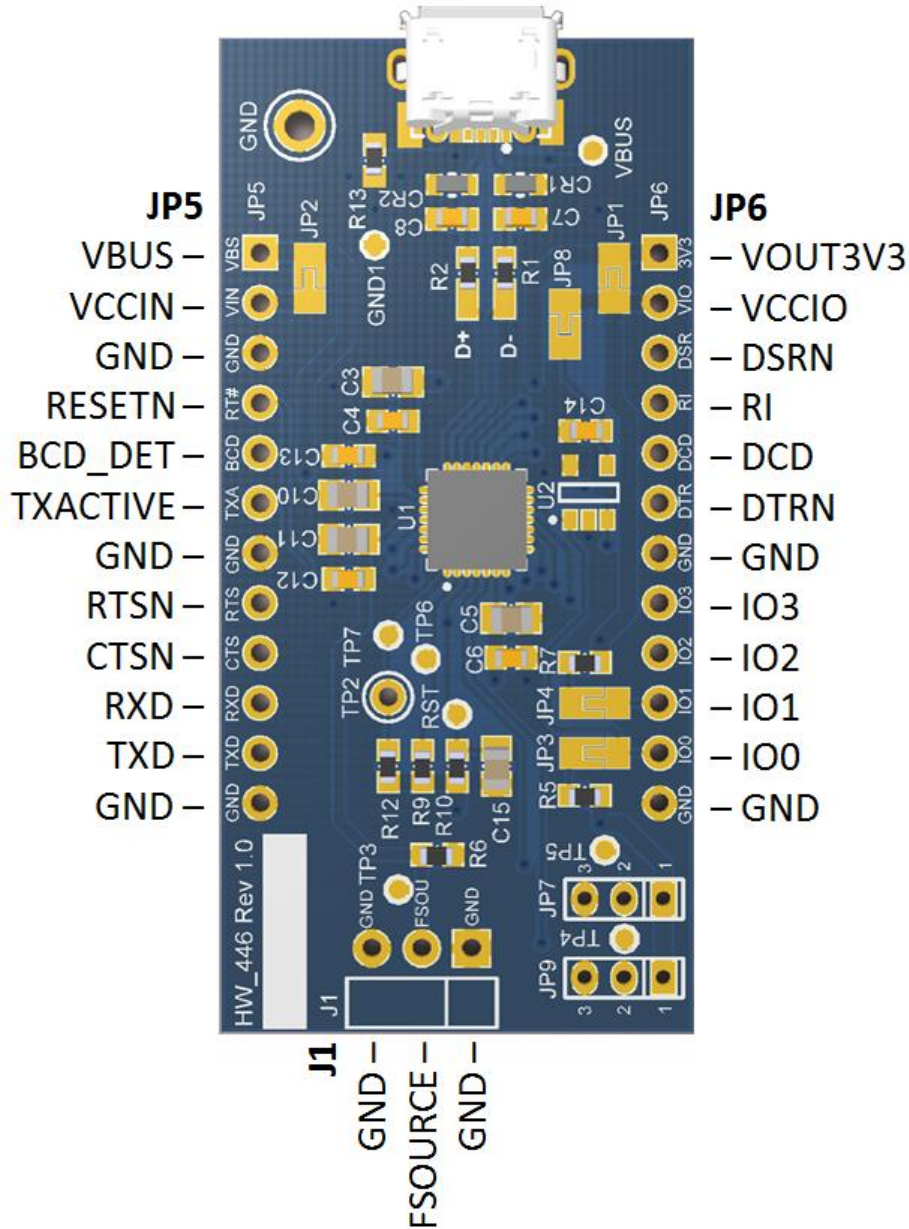

**Figure 4.1 Module Pin Out**

Figure 4.1 illustrates the signals available on the DIP pins. The information relating to the on-board jumpers will be described later in this chapter.

## 4.2 JP1/JP5/JP6 Signal Descriptions

Connector Pin	Name	Type	Description
J1-1	GND	Ground	Ground 0 volts.
J1-2	FSOURCE	Power	FT260 FSOURCE Pin (input).
J1-3	GND	Ground	Ground 0 volts.

**Table 4.1 JP1 Pin Out Description**

Connector Pin	Name	Type	Description
JP5-1	VBUS	Power	USB VBUS Power pin (output). The USB VBUS is connected to the FT260 VCCIN Pin through JP2 as default
JP5-2	VCCIN	Power	FT260 VCCIN Pin (input). The FT260 VCCIN is connected to the USB VBUS Pin through JP2 as default
JP5-3	GND	Ground	Ground 0 volts.
JP5-4	RESETN	Signal	FT260 RESETN Pin.
JP5-5	BCD_DET	Signal	FT260 DIO12 Pin.
JP5-6	TXACTIVE	Signal	FT260 DIO0 Pin.
JP5-7	GND	Ground	Ground 0 volts.
JP5-8	RTSN	Signal	FT260 DIO1 Pin.
JP5-9	CTSN	Signal	FT260 DIO2 Pin.
JP5-10	RXD	Signal	FT260 DIO3 Pin.
JP5-11	TXD	Signal	FT260 DIO4 Pin.
JP5-12	GND	Ground	Ground 0 volts.

**Table 4.2 JP5 Pin Out Description**

Connector Pin	Name	Type	Description
JP6-1	VOUT3V3	Power	FT260 VOUT3V3 Pin (output). The FT260 VOUT3V3 pin is connected to the FT260 VCCIO pin through JP1 as default
JP6-2	VCCIO	Power	FT260 VCCIO Pin (input). The FT260 VCCIO pin is connected to the FT260 VOUT3V3 Pin through JP1 as default
JP6-3	DSRN	Signal	FT260 DIO13 Pin.
JP6-4	RI	Signal	FT260 DIO11 Pin.
JP6-5	DCD	Signal	FT260 DIO10 Pin.
JP6-6	DTRN	Signal	FT260 DIO9 Pin.
JP6-7	GND	Ground	Ground 0 volts.
JP6-8	IO3	Signal	FT260 DIO8 Pin.
JP6-9	IO2	Signal	FT260 DIO7 Pin.
JP6-10	IO1	Signal	FT260 DIO6 Pin. The on-board I <sup>2</sup> C bus pull-up circuit is connected as default(JP4 shorted)
JP6-11	IO0	Signal	FT260 DIO5 Pin. The on-board I <sup>2</sup> C bus pull-up circuit is connected as default(JP3 shorted )
JP6-12	GND	Ground	Ground 0 volts.

**Table 4.3 JP6 Pin Out Description**

### 4.3 Jumper Descriptions

UMFT260EV1A provides two kinds of jumper: Solder jumper and Shunt jumper.

Jumper	Setting	Status	Description
JP1	Short	Default	VCCIO is connected to VOUT3V3. All I/O of the FT260 are working at 3.3V.
	Open	Non-Default	VCCIO is disconnected from VOUT3V3. The VCCIO should be connected to external power source, e.g. 1.8/2.5V/3.3V.
JP2	Short	Default	Bus-Powered mode. This setting creates a connection between VBUS and VCCIN.
	Open	Non-Default	Self-Powered mode. This setting removes the connection between VBUS and VCCIN. The VCCIN (JP5-2) should be connected to the external 5V source.
JP3	Short	Default	The on-board I <sup>2</sup> C bus pull-up circuit is connected to IO0 (JP6-11)
	Open	Non-Default	The on-board I <sup>2</sup> C bus pull-up circuit is removed from IO0 (JP6-11)
JP4	Short	Default	The on-board I <sup>2</sup> C bus pull-up circuit is connected to IO1 (JP6-10)
	Open	Non-Default	The on-board I <sup>2</sup> C bus pull-up circuit is removed from IO1 (JP6-10)
JP8	Short	Default	The on-board I <sup>2</sup> C EEPROM is enabled
	Open	Non-Default	The on-board I <sup>2</sup> C EEPROM is disabled

**Table 4.4 Solder Jumper Description**

Pin No.	Name	Type	Description
JP7-1	VCCIO	Power	Set DCNF0 High.
JP7-2	DCNF0	Signal	FT260 chip configuration selection bit 0. Refer to the <a href="#">FT260 datasheet</a>
JP7-3	GND	Ground	Set DCNF0 Low (Default).

**Table 4.5 JP7 Pin Description**

Pin No.	Name	Type	Description
JP9-1	VCCIO	Power	Set DCNF1 High.
JP9-2	DCNF1	Signal	FT260 chip configuration selection bit 1. Refer to <a href="#">the FT260 datasheet</a>
JP9-3	GND	Ground	Set DCNF1 Low (Default).

**Table 4.6 JP9 Pin Description**



## 5 Module Configurations

### 5.1 Power Configuration

#### A. Bus Powered Configuration

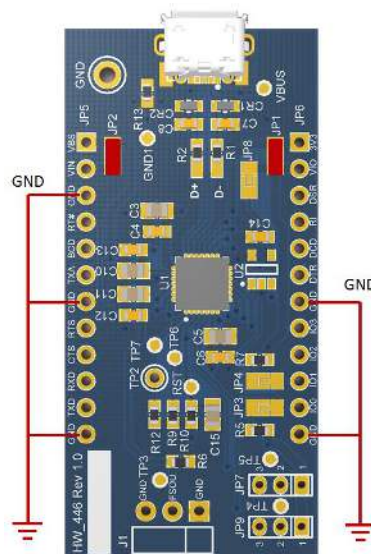

**Figure 5.1 Bus Powered Configuration: JP2 shorted**

Figure 5.1 illustrates the UMFT260EV1A module in a typical USB bus powered configuration. This is done by soldering the jumpers at JP1 and JP2. The UMFT260EV1A is shipped in this configuration as default.

#### B. Self Powered configuration

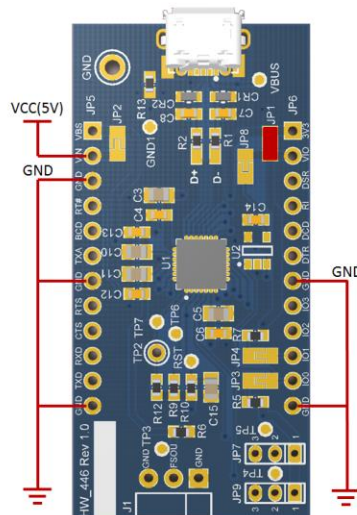

**Figure 5.2 Self Powered Configuration: JP1 shorted and JP2 opened**

Figure 5.2 illustrates the UMFT260EV1A module in a typical USB self powered configuration. In this case, the solder at jumpers JP2 is removed and the external VCC (5V) is connected to module JP5 Pin2 (VCCIN).

**Warning:** There should never be more than one power output supplying power to the same net at any one time. Shorting JP2 will cause a direct connection between two different power supplies, when a self-powered set-up is applied and the USB bus is connected resulting in the potential for damage to the module and other connected circuitry.

## 5.2 I/O Voltage Level Configuration

### A. Internal Regulator(3.3V) Configuration

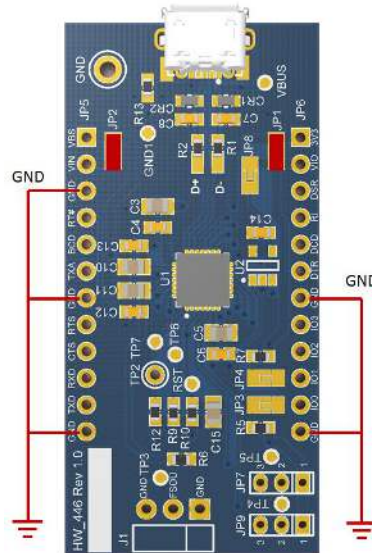

**Figure 5.3 I/O voltage level with internal regulator: JP1 shorted**

Figure 5.3 shows a configuration of USB bus powered and using the internal regulator for I/O voltage levels. The solder jumper JP1 allows the FT260 to use the internal 3.3V regulator. The FT260 VCCIO pin is connected to the FT260 VOUT3V3 pin through JP1.

### B. External Power Source Configuration

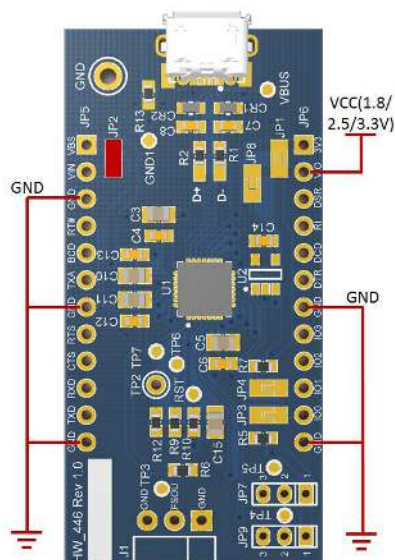

**Figure 5.4 I/O voltage level with external power source: JP1 opened**

Figure 5.4 shows a configuration of using an external power source for the FT260 IO supply voltage. After removing the solder at JP1 on the UMFT260EV1A module, the FT260 can apply the external power source to the FT260 VCCIO pin through JP6 Pin 1. FT260 VCCIO pin can accept 3.3V/2.5V/1.8V voltage levels for all the FT260 I/O pins.

### 5.3 I<sup>2</sup>C Bus Pull-up Configuration

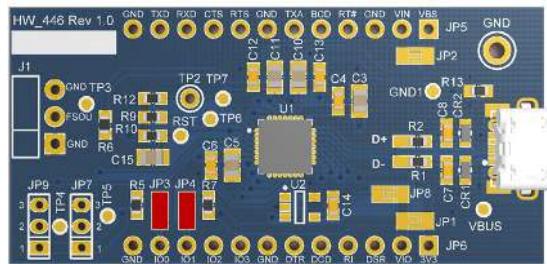

**Figure 5.5 Enable I<sup>2</sup>C interface pull high: JP3 shorted and JP4 shorted**

Figure 5.5 illustrates the location of JP3 and JP4 (marked in red) for I<sup>2</sup>C bus pull-up configuration. Since the default function of IO0 and IO1 is the I<sup>2</sup>C bus, the UMFT260EV1A connects the pull-up circuit to the I<sup>2</sup>C bus as default. If the IO0 and IO1 are configured as GPIO features, the user needs to remove the pull-up circuit by unsoldering JP3 and JP4.

### 5.4 On-board I<sup>2</sup>C EEPROM Configuration

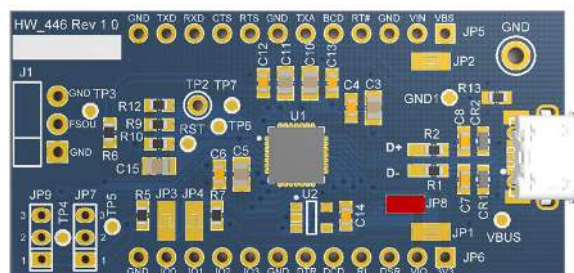
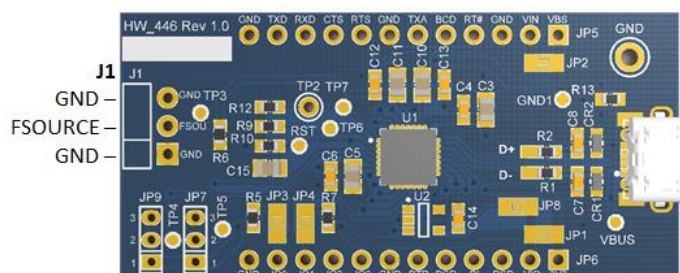

**Figure 5.6 Enable on-board I<sup>2</sup>C EEPROM: JP8 shorted**

Figure 5.6 illustrates the location of JP8 (marked in red) for I<sup>2</sup>C EEPROM configuration. The FT260 allows chip configuration settings and vendor specific parameters to be stored in an external EEPROM. The UMFT260EV1A populates the 2kbits EEPROM with address 0x50. If an on-board EEPROM is not required, de-solder JP8 to disable the EEPROM.

The EEPROM is programmed before shipping. Refer to the FT260 datasheet for default values.

### 5.5 Programming the FT260 On-Chip eFUSE



**Figure 5.7 Apply external voltage 3.8V to J1 Pin 2**

The FT260 On-Chip eFUSE can be programmed through the USB HID interface. For the UMFT260EV1A module, UMFTPD3A is required to program the FT260 eFUSE. UMFTPD3A will supply the 3.8V programming voltage to the FT260 FSOURCE pin through UMFT260EV1A module J1 Pin 2.

The datasheet of UMFTPD3A module is available at this link.

[http://www.ftdichip.com/Support/Documents/DataSheets/Modules/DS\\_UMFTPD3A.pdf](http://www.ftdichip.com/Support/Documents/DataSheets/Modules/DS_UMFTPD3A.pdf)

## 5.6 Power consumption

Parameter	Description	Mini.	Typical	Max.	Units	Conditions
$I_{VBUS1}$	VBUS Operating Current	-	24.2	-	mA	VBUS Powered, Function Mode
$I_{VBUS2}$	VBUS Operating Current	-	4.4	-	mA	VBUS Powered, IDLE Mode
$I_{VBUS3}$	VBUS Operating Current	-	400	-	$\mu$ A	VBUS Powered, Suspend Mode

**Table 5.1 Power Consumption**

## 6 Module Dimensions

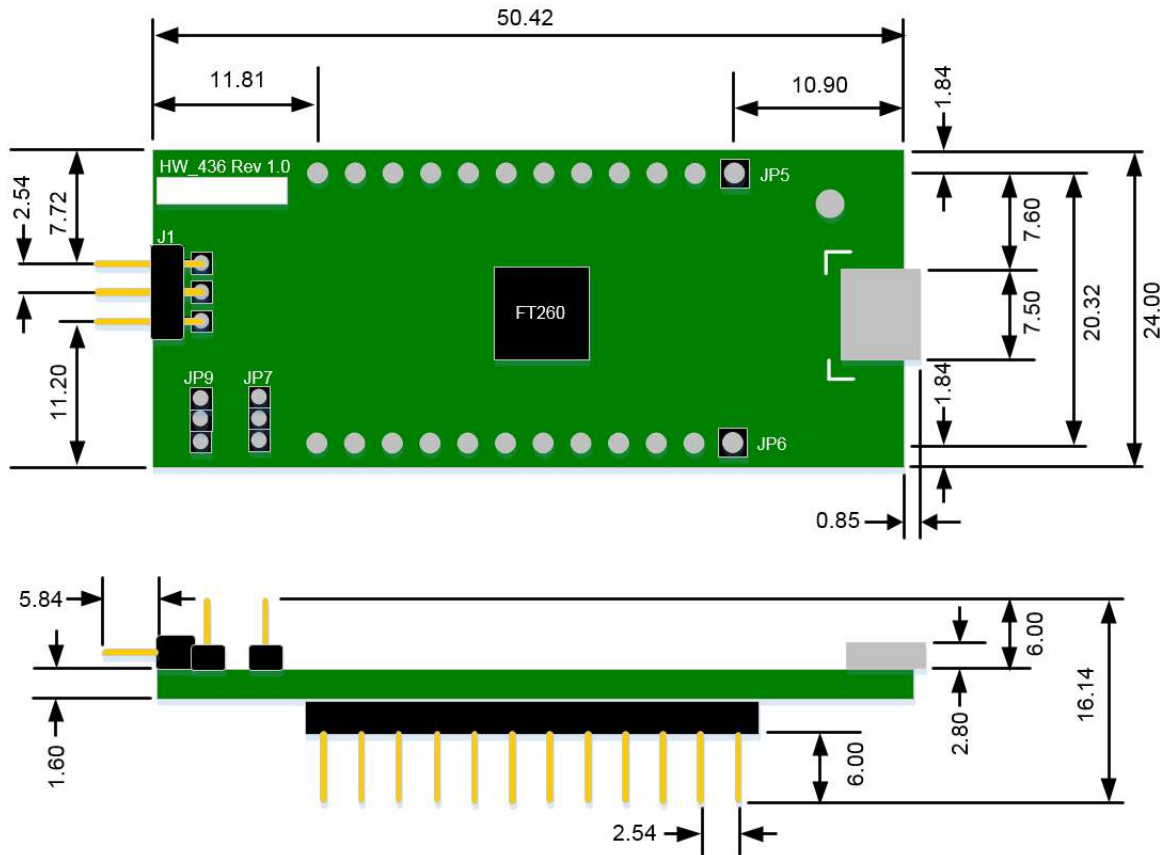

**Figure 6.1 UMFT260EV1A Module Dimensions**

All dimensions are given in millimetres.

The UMFT260EV1A module exclusively uses lead free components, and is fully compliant with European Union directive 2002/95/EC.

# 7 UMFT260EV1A Module Circuit Schematic

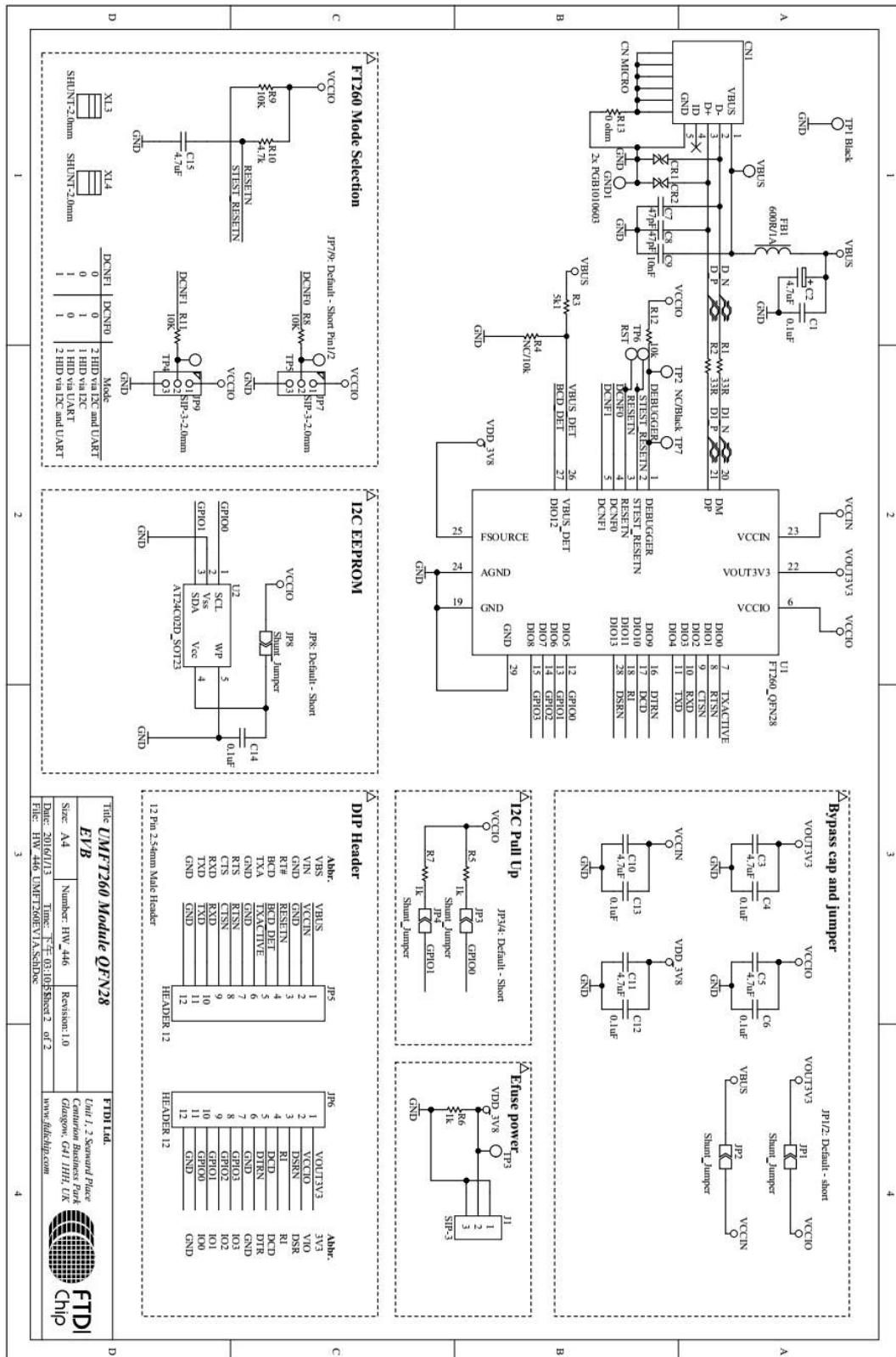

Figure 7.1 Module Circuit Schematic

## 8 Contact Information

### Head Office – Glasgow, UK

Unit 1, 2 Seaward Place, Centurion Business Park  
Glasgow G41 1HH  
United Kingdom  
Tel: +44 (0) 141 429 2777  
Fax: +44 (0) 141 429 2758

E-mail (Sales) [sales1@ftdichip.com](mailto:sales1@ftdichip.com)  
E-mail (Support) [support1@ftdichip.com](mailto:support1@ftdichip.com)  
E-mail (General Enquiries) [admin1@ftdichip.com](mailto:admin1@ftdichip.com)

### Branch Office – Tigard, Oregon, USA

7130 SW Fir Loop  
Tigard, OR 97223  
USA  
Tel: +1 (503) 547 0988  
Fax: +1 (503) 547 0987

E-Mail (Sales) [us.sales@ftdichip.com](mailto:us.sales@ftdichip.com)  
E-Mail (Support) [us.support@ftdichip.com](mailto:us.support@ftdichip.com)  
E-Mail (General Enquiries) [us.admin@ftdichip.com](mailto:us.admin@ftdichip.com)

### Branch Office – Taipei, Taiwan

2F, No. 516, Sec. 1, NeiHu Road  
Taipei 114  
Taiwan, R.O.C.  
Tel: +886 (0) 2 8797 1330  
Fax: +886 (0) 2 8751 9737

E-mail (Sales) [tw.sales1@ftdichip.com](mailto:tw.sales1@ftdichip.com)  
E-mail (Support) [tw.support1@ftdichip.com](mailto:tw.support1@ftdichip.com)  
E-mail (General Enquiries) [tw.admin1@ftdichip.com](mailto:tw.admin1@ftdichip.com)

### Branch Office – Shanghai, China

Room 1103, No. 666 West Huaihai Road,  
Shanghai, 200052  
China  
Tel: +86 (0)21 6235 1596  
Fax: +86 (0)21 6235 1595

E-mail (Sales) [cn.sales@ftdichip.com](mailto:cn.sales@ftdichip.com)  
E-mail (Support) [cn.support@ftdichip.com](mailto:cn.support@ftdichip.com)  
E-mail (General Enquiries) [cn.admin@ftdichip.com](mailto:cn.admin@ftdichip.com)

### Web Site

<http://ftdichip.com>

### Distributor and Sales Representatives

Please visit the Sales Network page of the [FTDI Web site](#) for the contact details of our distributor(s) and sales representative(s) in your country.

System and equipment manufacturers and designers are responsible to ensure that their systems, and any Future Technology Devices International Ltd (FTDI) devices incorporated in their systems, meet all applicable safety, regulatory and system-level performance requirements. All application-related information in this document (including application descriptions, suggested FTDI devices and other materials) is provided for reference only. While FTDI has taken care to assure it is accurate, this information is subject to customer confirmation, and FTDI disclaims all liability for system designs and for any applications assistance provided by FTDI. Use of FTDI devices in life support and/or safety applications is entirely at the user's risk, and the user agrees to defend, indemnify and hold harmless FTDI from any and all damages, claims, suits or expense resulting from such use. This document is subject to change without notice. No freedom to use patents or other intellectual property rights is implied by the publication of this document. Neither the whole nor any part of the information contained in, or the product described in this document, may be adapted or reproduced in any material or electronic form without the prior written consent of the copyright holder. Future Technology Devices International Ltd, Unit 1, 2 Seaward Place, Centurion Business Park, Glasgow G41 1HH, United Kingdom. Scotland Registered Company Number: SC136640

## Appendix A – References

### Document References

#### Application Notes

[AN\\_394 User Guide for FT260](#)

[AN\\_395 User Guide for LibFT260](#)

[AN\\_124 User Guide for FTDI FT\\_Prog Utility](#)

[AN\\_184 FTDI Device Input Output Pin States](#)

[AN\\_175 Battery Charger Detection Over USB with FT-X Devices](#)

#### Technical Notes

[TN\\_100 USB Vendor ID/Product ID Guidelines](#)

[TN\\_111 What is UART](#)

#### Datasheets

[DS\\_FT260](#)

[UMFTPD3A Program Module Datasheet](#)

#### FT\_PROG Utility

[http://www.ftdichip.com/Support/Utilities.htm#FT\\_Prog](http://www.ftdichip.com/Support/Utilities.htm#FT_Prog)

#### Related Document or Specification

<http://i2c2p.twibright.com/spec/i2c.pdf>

[https://msdn.microsoft.com/en-us/library/windows/hardware/dn642101\(v=vs.85\).aspx](https://msdn.microsoft.com/en-us/library/windows/hardware/dn642101(v=vs.85).aspx)

[https://msdn.microsoft.com/en-US/library/jj131705\(v=vs.85\).aspx](https://msdn.microsoft.com/en-US/library/jj131705(v=vs.85).aspx)

### Acronyms and Abbreviations

Terms	Description
eFUSE	Electrical poly fuse
GPIO	General purpose I/O
HID	Human interface device
I <sup>2</sup> C	Inter integrated Circuit
UART	Universal Asynchronous Receiver/Transmitter
USB	Universal Serial Bus



## Appendix B – List of Figures and Tables

### List of Figures

Figure 4.1 Module Pin Out .....	5
Figure 5.1 Bus Powered Configuration: JP2 shorted.....	9
Figure 5.2 Self Powered Configuration: JP1 shorted and JP2 opened .....	9
Figure 5.3 I/O voltage level with internal regulator: JP1 shorted .....	10
Figure 5.4 I/O voltage level with external power source: JP1 opened .....	10
Figure 5.5 Enable I <sup>2</sup> C interface pull high: JP3 shorted and JP4 shorted .....	11
Figure 5.6 Enable on-board I <sup>2</sup> C EEPROM: JP8 shorted .....	11
Figure 5.7 Apply external voltage 3.8V to J1 Pin 2 .....	11
Figure 6.1 UMFT260EV1A Module Dimensions .....	13
Figure 7.1 Module Circuit Schematic.....	14

### List of Tables

Table 4.1 JP1 Pin Out Description .....	6
Table 4.2 JP5 Pin Out Description .....	6
Table 4.3 JP6 Pin Out Description .....	7
Table 4.4 Solder Jumper Description.....	8
Table 4.5 JP7 Pin Description.....	8
Table 4.6 JP9 Pin Description.....	8
Table 5.1 Power Consumption .....	12

## Appendix C – Revision History

Document Title: UMFT260EV1A Datasheet  
Document Reference No.: FT\_001277  
Clearance No.: FTDI# 499  
Product Page: <http://www.ftdichip.com>  
Document Feedback: [Send Feedback](#)

<b>Revision</b>	<b>Changes</b>	<b>Date</b>
Version 1.0	Initial Release	2016-04-27