

Gigabit 4x4 CROSSPOINT SWITCH

FEATURES

- Up to 4.25 Gbps Operation
- Non-blocking Architecture Allows Each Output to be Connected to Any Input
- 30 ps of Deterministic Jitter
- Selectable Transmit Pre-Emphasis Per Lane
- Selectable Receive Equalization
- Available Packaging 48 Pin QFN
- Propagation Delay Times: 500 ps Typical
- Inputs Electrically Compatible With CML Signal Levels
- Operates From a Single 3.3-V Supply
- Ability to 3-STATE outputs
- Low Power: 560 mW
- Integrated Termination Resistors

APPLICATIONS

- Clock Buffering/Clock MUXing
- Wireless Base Stations
- High-Speed Network Routing
- Telecom/Datacom
- XAUI 802.3ae Protocol Backplane Redundancy

DESCRIPTION

The SN65LVCP404 is a 4x4 non-blocking crosspoint switch in a flow-through pin-out allowing for ease in PCB layout. VML signaling is used to achieve a high-speed data throughput while using low power. Each of the output drivers includes a 4:1 multiplexer to allow any input to be routed to any output. Internal signal paths are fully differential to achieve the high signaling speeds while maintaining low signal skews. The SN65LVCP404 incorporates 100-Ω termination resistors for those applications where board space is a premium. Built-in transmit pre-emphasis and receive equalization for superior signal integrity performance.

The SN65LVCP404 is characterized for operation from -40°C to 85°C.

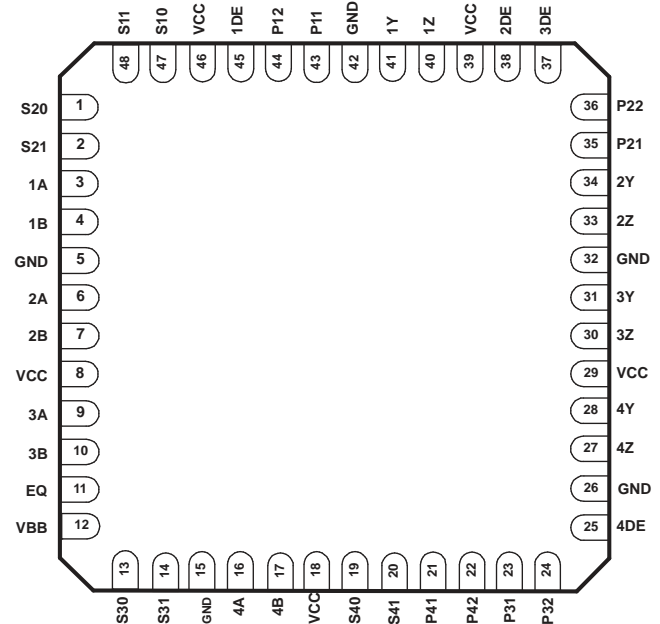

Please be aware that an important notice concerning availability, standard warranty, and use in critical applications of Texas Instruments semiconductor products and disclaimers thereto appears at the end of this data sheet.



These devices have limited built-in ESD protection. The leads should be shorted together or the device placed in conductive foam during storage or handling to prevent electrostatic damage to the MOS gates.

LOGIC DIAGRAM

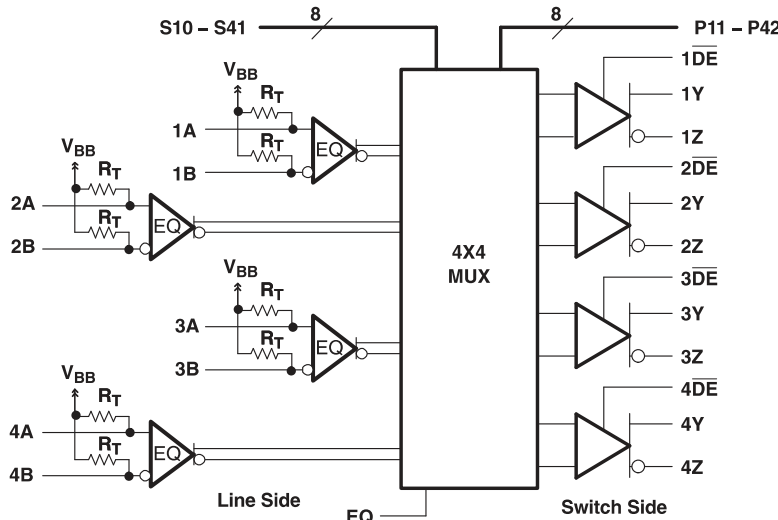

Note:

V_{BB}: Receiver input internal biasing voltage (allows ac coupling)

EQ: Input Equalizer (compensates for frequency dependent transmission line loss of backplanes)

R_T: Internal 50-Ohm receiver termination (100-Ohm differential)

Preemphasis: Output precompensation for transmission line losses

TERMINAL FUNCTIONS

| TERMINAL | | TYPE | DESCRIPTION |
|------------------------|----------------------------------|---|--|
| NAME | NO. | | |
| High Speed I/O | | | |
| xA xB | 3, 6, 9, 16 4, 7, 10, 17 | Differential Inputs (with 50-Ω termination to V _{bb}) xA=P; xB=N | Line Side Differential Inputs CML compatible |
| xY xZ | 41, 34, 31, 28 40, 33, 30, 27 | Differential Output xY=P; xZ=N | Switch Side Differential Outputs. VML |
| Control Signals | | | |
| x \overline{DE} | 45, 38, 37, 25 | Input | Data Enable; Active Low; LVTTTL; When not enabled the output is in 3-STATE mode for power savings |
| S10 - S41 | 1, 2, 13, 14, 19, 20, 47, 48 | Input; S1x = Channel 1 bit one | Switching Selection; LVTTTL |
| P11-P42 | 43, 44, 35, 36, 23, 24, 21, 22 | Input; P1x- Channel 1 bit one | Output Preemphasis Control; LVTTTL |
| EQ | 11 | Input; Selection for receive equalization setting | EQ = 1 (default) is for the 5 dB setting, EQ = 0 is for the 12 dB setting |
| Power Supply | | | |
| VCC | 8, 18, 29, 39, 46 | Power | Power Supply 3.3v ±5% |
| GND | 5, 15, 26, 32, 42 | | |
| Thermal Pad | | | The ground center pad of the package must be connected to GND plane. |
| V _{BB} | 12 | Input | Receiver input biasing voltage. For ac coupling, V _{BB} should be left floating for optimal bias value. For dc coupling, V _{BB} can be driven to change the common mode. V _{BB} should not be tied to ground. |

EQUIVALENT INPUT AND OUTPUT SCHEMATIC DIAGRAMS

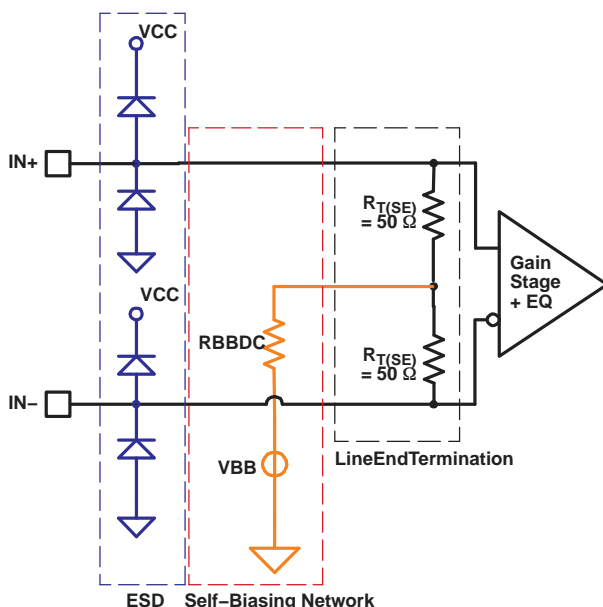

Figure 1. Equivalent Input Circuit Design

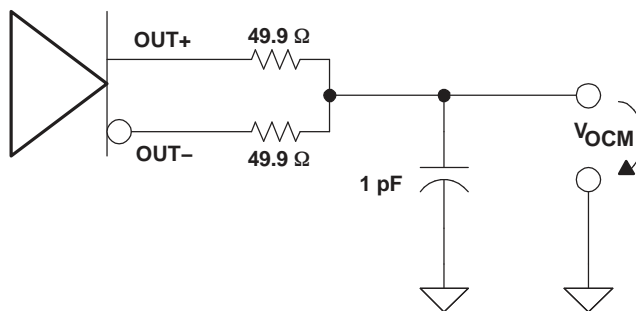

Figure 2. Common-Mode Output Voltage Test Circuit

Table 1. CROSSPOINT LOGIC TABLES

| OUTPUT CHANNEL 1 | | | OUTPUT CHANNEL 2 | | | OUTPUT CHANNEL 3 | | | OUTPUT CHANNEL 4 | | |
|------------------|-----|----------------|------------------|-----|----------------|------------------|-----|----------------|------------------|-----|----------------|
| CONTROL PINS | | INPUT SELECTED | CONTROL PINS | | INPUT SELECTED | CONTROL PINS | | INPUT SELECTED | CONTROL PINS | | INPUT SELECTED |
| S10 | S11 | 1Y/1Z | S20 | S21 | 2Y/2Z | S30 | S31 | 3Y/3Z | S40 | S41 | 4Y/4Z |
| 0 | 0 | 1A/1B | 0 | 0 | 1A/1B | 0 | 0 | 1A/1B | 0 | 0 | 1A/1B |
| 0 | 1 | 2A/2B | 0 | 1 | 2A/2B | 0 | 1 | 2A/2B | 0 | 1 | 2A/2B |
| 1 | 0 | 3A/3B | 1 | 0 | 3A/3B | 1 | 0 | 3A/3B | 1 | 0 | 3A/3B |
| 1 | 1 | 4A/4B | 1 | 1 | 4A/4B | 1 | 1 | 4A/4B | 1 | 1 | 4A/4B |

AVAILABLE OPTIONS

| T _A | DESCRIPTION | PACKAGED DEVICE ⁽¹⁾ |
|----------------|--------------------|--------------------------------|
| | | RGZ (48 pin) |
| -40°C to 85°C | Serial multiplexer | SN65LVCP404 |

(1) The package is available taped and reeled. Add an R suffix to device types (e.g., SN65LVCP404RGZR).

PACKAGE THERMAL CHARACTERISTICS

| PACKAGE THERMAL CHARACTERISTICS ⁽¹⁾ | | NOM | UNIT |
|--|---|------|------|
| θ_{JA} (junction-to-ambient) | 4-layer JEDEC Board (JESD51-7) using eight GND-vias $\theta=0.2$ on the center pad as shown in the section: <i>Recommended PCB footprint</i> with boundary and environment conditions of JEDEC Board (JESD51-2) | 33 | °C/W |
| θ_{JB} (junction-to-board) | | 20 | °C/W |
| θ_{JC} (junction-to-case) | | 23.6 | °C/W |
| PSI-jt (junction-to-top pseudo) | | 0.6 | °C/W |
| PSI-jb (junction-to-board pseudo) | | 19.4 | °C/W |
| θ_{JP} (junction-to-pad) | | 5.4 | °C/W |

(1) See application note [SPRA953](http://www-s.ti.com/sc/psheets/spra953/spra953.pdf) for a detailed explanation of thermal parameters (<http://www-s.ti.com/sc/psheets/spra953/spra953.pdf>).

ABSOLUTE MAXIMUM RATINGS

over operating free-air temperature range (unless otherwise noted)⁽¹⁾

| | | UNIT |
|---------------|---|---|
| V_{CC} | Supply voltage range ⁽²⁾ | –0.5 V to 6 V |
| Voltage range | Control inputs, all outputs | –0.5 V to ($V_{CC} + 0.5$ V) |
| | Receiver inputs | –0.5 V to 4 V |
| ESD | Human Body Model ⁽³⁾ | All pins 3 kV |
| | Charged-Device Model ⁽⁴⁾ | All pins 500 V |
| T_J | Maximum junction temperature | See Package Thermal Characteristics Table |
| | Moisture sensitivity level | 2 |
| | Reflow temperature package soldering, 4 seconds | 260°C |

(1) Stresses beyond those listed under absolute maximum ratings may cause permanent damage to the device. These are stress ratings only and functional operation of the device at these or any other conditions beyond those indicated under recommended operating conditions is not implied. Exposure to absolute-maximum-rated conditions for extended periods may affect device reliability.

(2) All voltage values, except differential I/O bus voltages, are with respect to network ground terminal.

(3) Tested in accordance with JEDEC Standard 22, Test Method A114-A.

(4) Tested in accordance with JEDEC Standard 22, Test Method C101.

RECOMMENDED OPERATING CONDITIONS

| | | MIN | NOM | MAX | UNIT | |
|-----------------------------|---|---|-----|-----------------------|--|------------------|
| dR | Operating data rate | | | 4.25 | Gbps | |
| V _{CC} | Supply voltage | 3.135 | 3.3 | 3.465 | V | |
| V _{CC(N)} | Supply voltage noise amplitude | 10 Hz to 2.125 GHz | | 20 | mV | |
| T _J | Junction temperature | | | 125 | °C | |
| T _A | Operating free-air temperature ⁽¹⁾ | -40 | | 85 | °C | |
| DIFFERENTIAL INPUTS | | | | | | |
| V _{ID} | Receiver peak-to-peak differential input voltage ⁽²⁾ | dR _(in) ≤ 4.25 Gbps | | 100 | 1750 | mV _{PP} |
| | | 1.25 Gbps < dR _(in) ≤ 4.25 Gbps | | 100 | 1560 | mV _{PP} |
| | | dR _(in) > 4.25 Gbps | | 100 | 1000 | mV _{PP} |
| V _{ICM} | Receiver common-mode input voltage | Note: for best jitter performance ac coupling is recommended. | | 1.5 | 1.6 V _{CC} - $\frac{ V_{ID} }{2}$ | V |
| CONTROL INPUTS | | | | | | |
| V _{IH} | High-level input voltage | 2 | | V _{CC} + 0.3 | V | |
| V _{IL} | Low-level input voltage | -0.3 | | 0.8 | V | |
| DIFFERENTIAL OUTPUTS | | | | | | |
| R _L | Differential load resistance | 80 | 100 | 120 | Ω | |

(1) Maximum free-air temperature operation is allowed as long as the device maximum junction temperature is not exceeded.

(2) Differential input voltage V_{ID} is defined as |IN₊ - IN₋|.

ELECTRICAL CHARACTERISTICS

over operating free-air temperature range (unless otherwise noted)

| PARAMETER | TEST CONDITIONS | MIN | TYP ⁽¹⁾ | MAX | UNIT |
|-----------------------------|--|---|--------------------|------|------------------|
| DIFFERENTIAL INPUTS | | | | | |
| V _{IT+} | Positive going differential input high threshold | | | 50 | mV |
| V _{IT-} | Negative going differential input low threshold | -50 | | | mV |
| A _(EQ) | Equalizer gain | at 1.875 GHz (EQ=0) | | 12 | dB |
| R _{T(D)} | Termination resistance, differential | 80 | 100 | 120 | Ω |
| V _{BB} | Open-circuit input voltage (input self-bias voltage) | AC-coupled inputs | | 1.6 | V |
| R _(BBDC) | Biassing network dc impedance | | 30 | | kΩ |
| R _(BBAC) | Biassing network ac impedance | 375 MHz | 42 | | Ω |
| | | 2.125 GHz | 8.4 | | |
| DIFFERENTIAL OUTPUTS | | | | | |
| V _{ODH} | High-level output voltage | R _L = 100 Ω ±1%, P _{X_2} = P _{X_1} = 0; 4 Gbps alternating 1010-pattern; Figure 3 | | 650 | mV _{PP} |
| V _{ODL} | Low-level output voltage | | | -650 | mV _{PP} |
| V _{ODB(PP)} | Output differential voltage without preemphasis ⁽²⁾ | | | 1000 | 1300 |
| V _{OCM} | Output common mode voltage | | 1.65 | | V |
| ΔV _{OC(SS)} | Change in steady-state common-mode output voltage between logic states | See Figure 2 | | 1 | mV |

(1) All typical values are at T_A = 25°C and V_{CC} = 3.3 V supply unless otherwise noted. They are for reference purposes and are not production tested.

(2) Differential output voltage V_(ODB) is defined as |OUT₊ - OUT₋|.

ELECTRICAL CHARACTERISTICS (continued)

over operating free-air temperature range (unless otherwise noted)

| PARAMETER | | TEST CONDITIONS | | MIN | TYP ⁽¹⁾ | MAX | UNIT |
|--------------------------|---|--|-------------------------------------|------|--------------------|-----|------------|
| $V_{(PE)}$ | Output preemphasis voltage ratio, $\frac{V_{ODB(PP)}}{V_{ODPE(PP)}}$ | $R_L = 100 \Omega \pm 1\%$; $x = L$ or S ; See Figure 3 | $Px_2:Px_1 = 00$ | | 0 | | dB |
| | | | $Px_2:Px_1 = 01$ | | 3 | | |
| | | | $Px_2:Px_1 = 10$ | | 6 | | |
| | | | $Px_2:Px_1 = 11$ | | 9 | | |
| $t_{(PRE)}$ | Preemphasis duration measurement | Output preemphasis is set to 9 dB during test $Px_x = 1$; Measured with a 100-MHz clock signal; $R_L = 100 \Omega \pm 1\%$, See Figure 4 | | | 175 | | ps |
| r_o | Output resistance | Differential on-chip termination between OUT+ and OUT– | | | 100 | | Ω |
| CONTROL INPUTS | | | | | | | |
| I_{IH} | High-level Input current | $V_{IN} = V_{CC}$ | | | | 5 | μA |
| I_{IL} | Low-level Input current | $V_{IN} = GND$ | | -125 | -90 | | μA |
| $R_{(PU)}$ | Pullup resistance | | | | 35 | | k Ω |
| POWER CONSUMPTION | | | | | | | |
| P_D | Device power dissipation | All outputs terminated 100 Ω | | | 560 | 750 | mW |
| P_Z | Device power dissipation in 3-State | All outputs in 3-state | | | | 600 | mW |
| I_{CC} | Device current consumption | All outputs terminated 100 Ω | PRBS 2^{7-1} pattern at 4.25 Gbps | | | 220 | mA |

SWITCHING CHARACTERISTICS

over operating free-air temperature range (unless otherwise noted)

| PARAMETER | | TEST CONDITIONS | | MIN | TYP ⁽¹⁾ | MAX | UNIT |
|-----------------------------|---|--|--|-----|--------------------|-----|--------|
| MULTIPLEXER | | | | | | | |
| $t_{(SM)}$ | Multiplexer switch time | Multiplexer to valid output | | | 3 | 6 | ns |
| DIFFERENTIAL OUTPUTS | | | | | | | |
| t_{PLH} | Low-to-high propagation delay | Propagation delay input to output See Figure 6 | | | 0.5 | 0.7 | ns |
| t_{PHL} | High-to-low propagation delay | | | | 0.5 | 0.7 | ns |
| t_r | Rise time | 20% to 80% of $V_{O(DB)}$; Test Pattern: 100-MHz clock signal; See Figure 5 and Figure 8 | | | 80 | | ps |
| t_f | Fall time | | | | 80 | | ps |
| $t_{sk(p)}$ | Pulse skew, $ t_{PHL} - t_{PLH} ^{(2)}$ | | | | | 20 | ps |
| $t_{sk(o)}$ | Output skew ⁽³⁾ | All outputs terminated with 100 Ω | | | 25 | 100 | ps |
| $t_{sk(pp)}$ | Part-to-part skew ⁽⁴⁾ | | | | | 300 | ps |
| t_{zd} | 3-State switch time to Disable | Assumes 50 Ω to V_{cm} and 150 pF load on each output | | | | 20 | ns |
| t_{ze} | 3-State switch time to Enable | Assumes 50 Ω to V_{cm} and 150 pF load on each output | | | | 10 | ns |
| RJ | Device random jitter, rms | See Figure 8 for test circuit. BERT setting 10^{-15} Alternating 10-pattern. | | | 0.8 | 2 | ps-rms |

(1) All typical values are at 25°C and with 3.3 V supply unless otherwise noted.

(2) $t_{sk(p)}$ is the magnitude of the time difference between the t_{PLH} and t_{PHL} of any output of a single device.(3) $t_{sk(o)}$ is the magnitude of the time difference between the t_{PLH} and t_{PHL} of any two outputs of a single device.(4) $t_{sk(pp)}$ is the magnitude of the difference in propagation delay times between any specified terminals of two devices when both devices operate with the same supply voltages, at the same temperature, and have identical packages and test circuits.

SWITCHING CHARACTERISTICS (continued)

over operating free-air temperature range (unless otherwise noted)

| PARAMETER | | TEST CONDITIONS | | | MIN | TYP ⁽¹⁾ | MAX | UNIT |
|-----------|--|---|-------------------------------|--|-----|--------------------|-----|------|
| DJ | Intrinsic deterministic device jitter ⁽⁵⁾⁽⁶⁾ , peak-to-peak | 0 dB preemphasis (PRE _x = 0); See Figure 8 for the test circuit. | PRBS 2 ⁷⁻¹ pattern | 4.25 Gbps | | | 30 | ps |
| | Absolute deterministic output jitter ⁽⁷⁾ , peak-to-peak | 0 dB preemphasis (PRE _x = 0); See Figure 8 for the test circuit. | PRBS 2 ⁷⁻¹ pattern | 1.25Gbps; EQ=1 Over 25-inch FR4 trace 4.25 Gbps; EQ=0 Over FR4 trace 2-inch to 43 inches long | | 7 | | ps |
| | | | | | | 20 | | |

- (5) Intrinsic deterministic device jitter is a measurement of the deterministic jitter contribution from the device. It is derived by the equation $(DJ_{(OUT)} - DJ_{(IN)})$, where $DJ_{(OUT)}$ is the total peak-to-peak deterministic jitter measured at the output of the device in PSPP. $DJ_{(IN)}$ is the peak-to-peak deterministic jitter of the pattern generator driving the device.
- (6) The SN65LVCP404 built-in passive input equalizer compensates for ISI. For a 25-inch FR4 transmission line with 8-mil trace width, the LVCP404 typically reduces jitter by 60 ps from the device input to the device output.
- (7) Absolute deterministic output jitter reflects the deterministic jitter measured at the SN65LVCP404 output. The value is a real measured value with a Bit error tester as described in [Figure 8](#). The absolute DJ reflects the sum of all deterministic jitter components accumulated over the link: $DJ_{(absolute)} = DJ_{(Signal\ generator)} + DJ_{(transmission\ line)} + DJ_{(intrinsic(LVCP404))}$.

Table 2. Preemphasis Controls PL_2, PL_1, PS_2, and PS_1

| Px_2 ⁽¹⁾ | Px_1 ⁽¹⁾ | OUTPUT PREEMPHASIS LEVEL IN dB | OUTPUT LEVEL IN mVpp | | TYPICAL FR4 TRACE LENGTH |
|---------------------|---------------------|--------------------------------|----------------------|----------------|--------------------------|
| | | | DE-EMPHASIZED | PRE-EMPHASIZED | |
| 0 | 0 | 0 dB | 1200 | 1200 | 10 inches of FR4 trace |
| 0 | 1 | 3 dB | 850 | 1200 | 20 inches of FR4 trace |
| 1 | 0 | 6 dB | 600 | 1200 | 30 inches of FR4 trace |
| 1 | 1 | 9 dB | 425 | 1200 | 40 inches of FR4 trace |

(1) x = L or S

Table 3. Receive Equalization Settings

| EQ | EQUALIZATION | TYPICAL TRACE |
|----|--------------|------------------|
| 1 | 5 dB | 25 inches of FR4 |
| 0 | 12 dB | 43 inches of FR4 |

PARAMETER MEASUREMENT INFORMATION

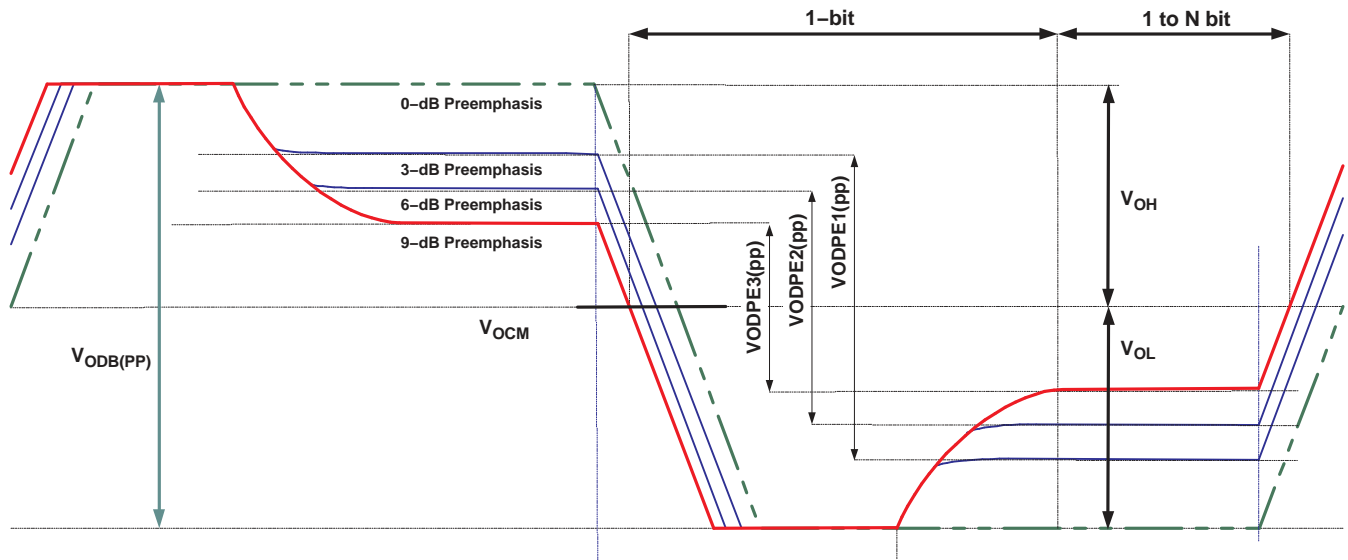

Figure 3. Preemphasis and Output Voltage Waveforms and Definitions

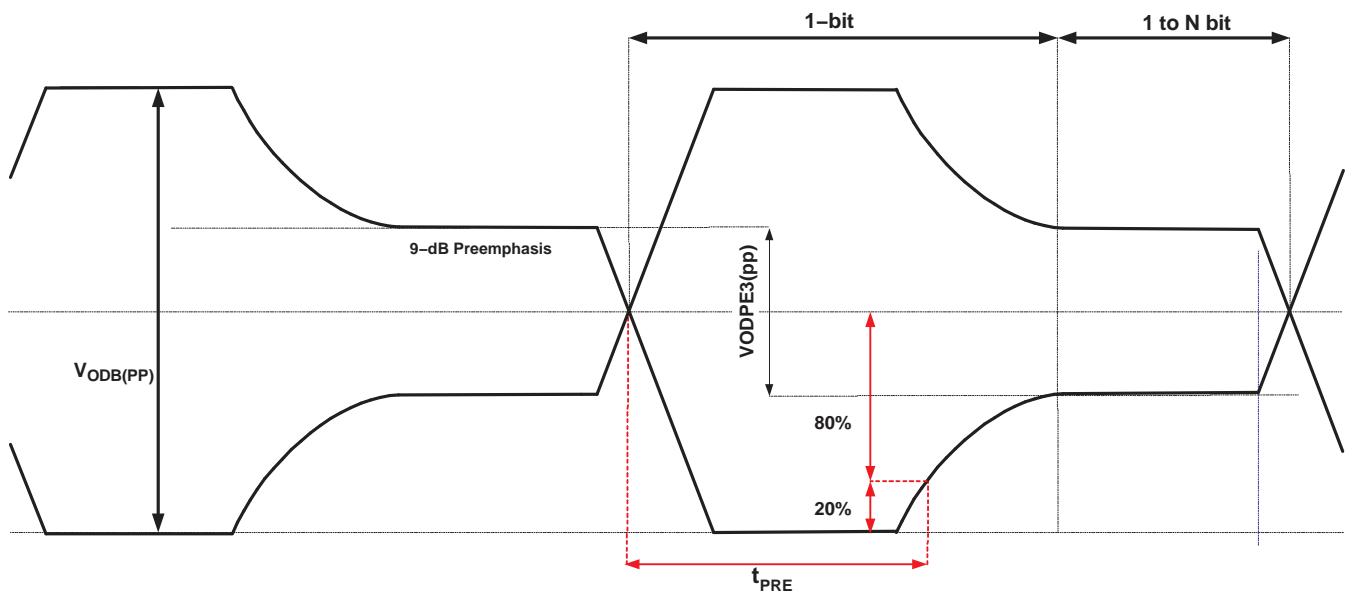

Figure 4. t_{PRE} Preemphasis Duration Measurement

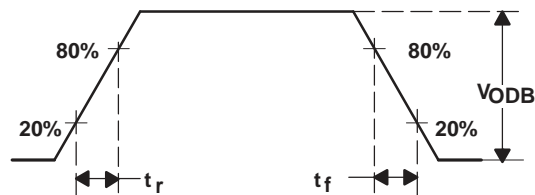

Figure 5. Driver Output Transition Time

PARAMETER MEASUREMENT INFORMATION (continued)

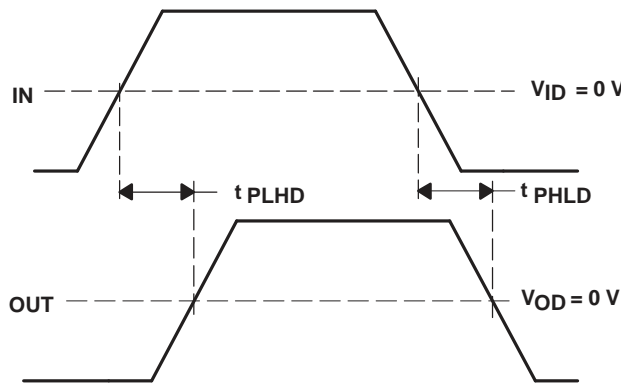
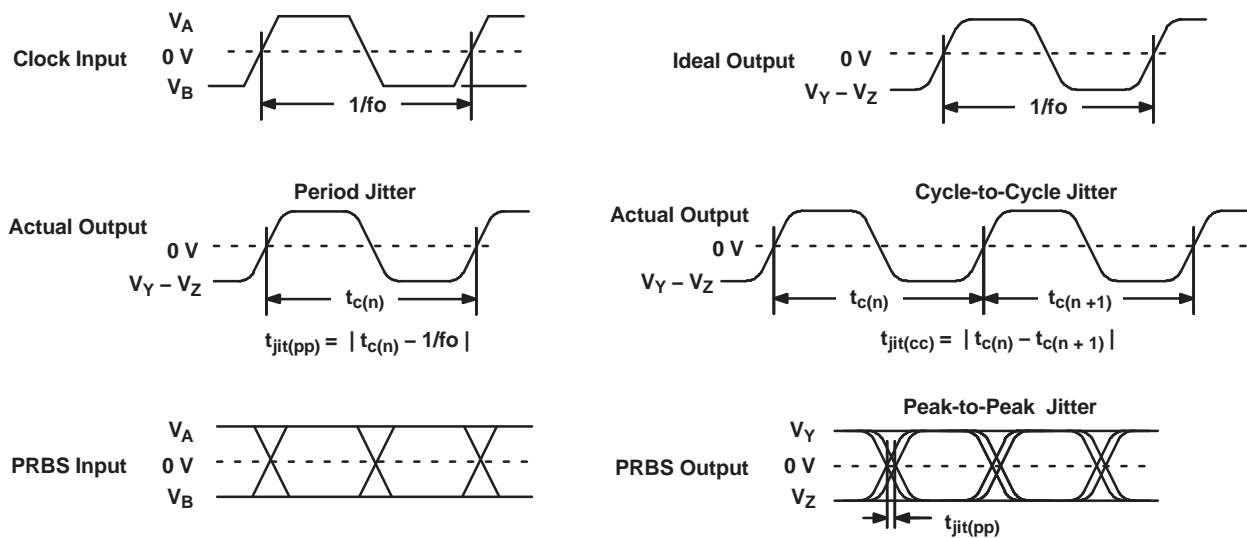

Figure 6. Propagation Delay Input to Output



- A. All input pulses are supplied by an Agilent 81250 Stimulus System.
- B. The measurement is made with the AgilentParBert measurement software.

Figure 7. Driver Jitter Measurement Waveforms

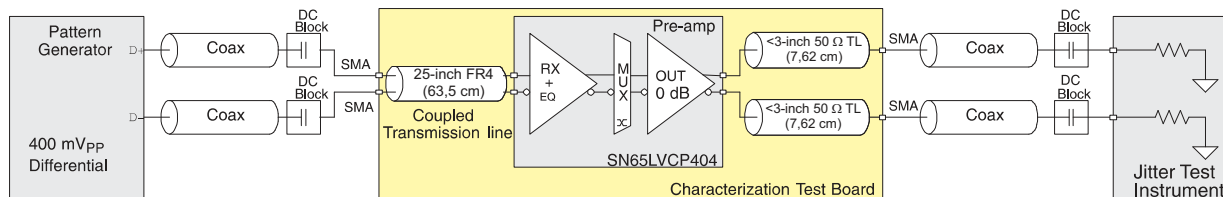
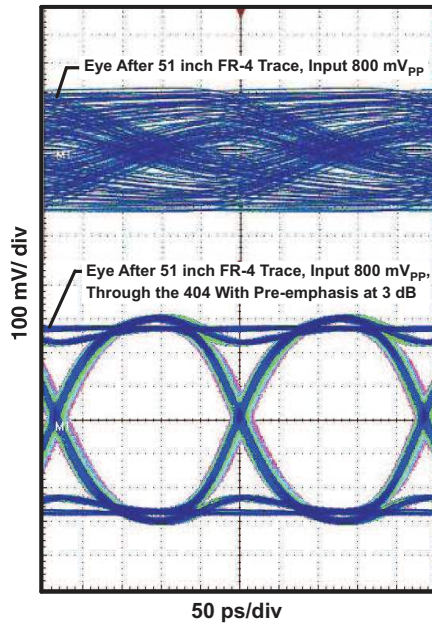

Figure 8. AC Test Circuit — Jitter and Output Rise Time Test Circuit

The SN65LVCP404 input equalizer provides 5-dB frequency gain to compensate for frequency loss of a shorter backplane transmission line. For characterization purposes, a 25-inch (63,5 cm) FR-4 coupled transmission line is used in place of the backplane trace. The 25-inch trace provides roughly 5 dB of attenuation between 375 MHz and 2.125 GHz, representing closely the characteristics of a short backplane trace. The loss tangent of the FR4 in the test board is 0.018 with an effective $\epsilon(r)$ of 4.1.

TYPICAL DEVICE BEHAVIOR



NOTE: 51 Inches (129.54 cm) Input Trace, dR = 4.25 Gbps; 2^{7-1} PRBS
 Figure 9. Data Input and Output Pattern

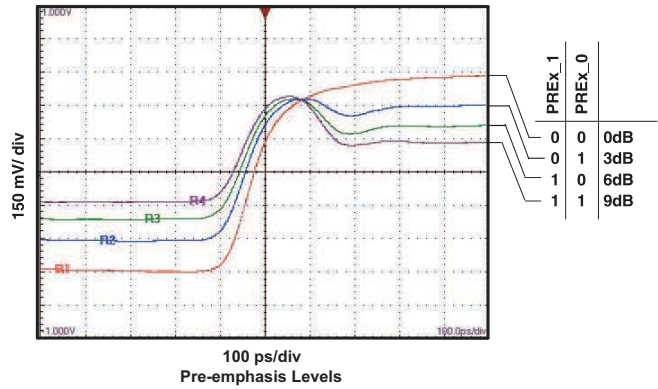

Figure 10. Preemphasis Signal Shape

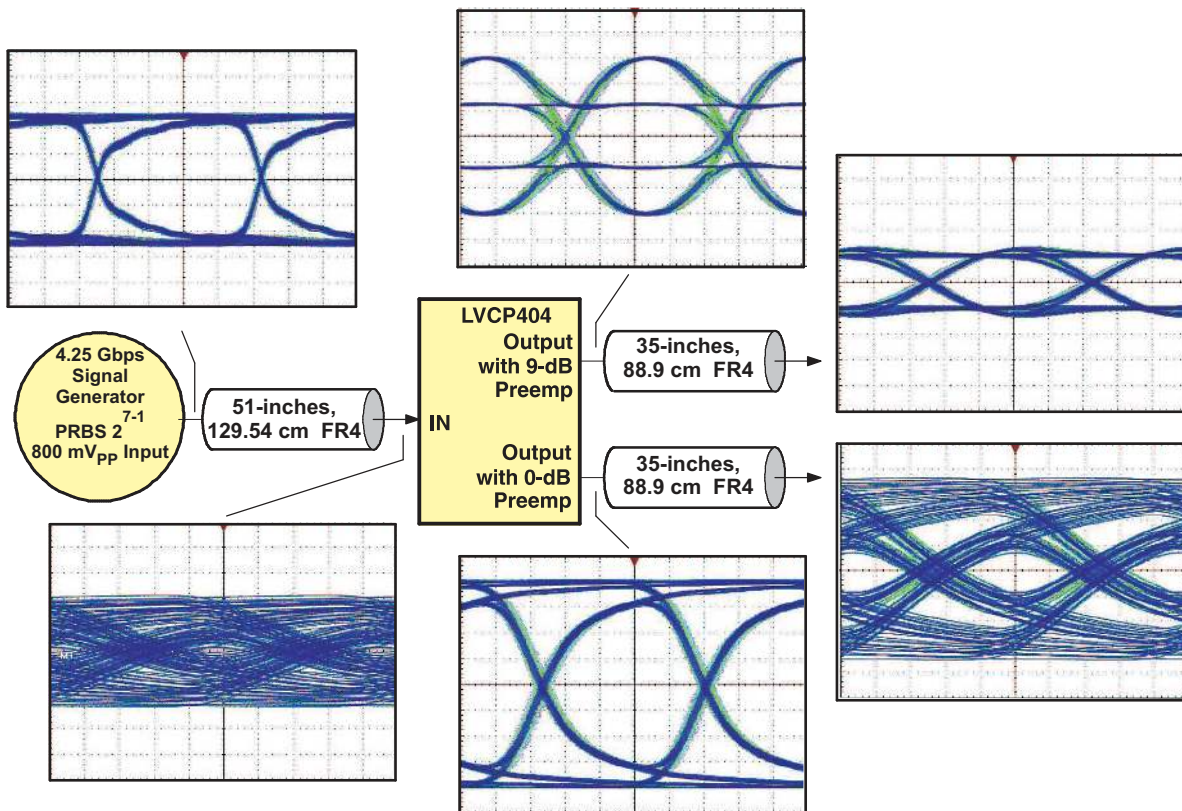

Figure 11. Data Output Pattern

TYPICAL CHARACTERISTICS

DETERMINISTIC OUTPUT JITTER vs DATA RATE

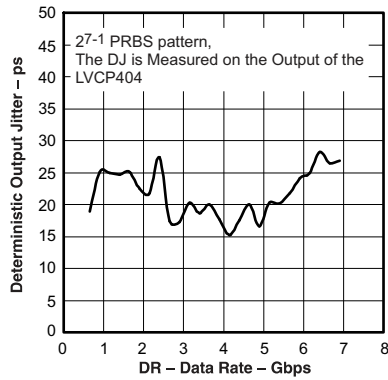

Figure 12.

DETERMINISTIC OUTPUT JITTER vs DIFFERENTIAL INPUT AMPLITUDE

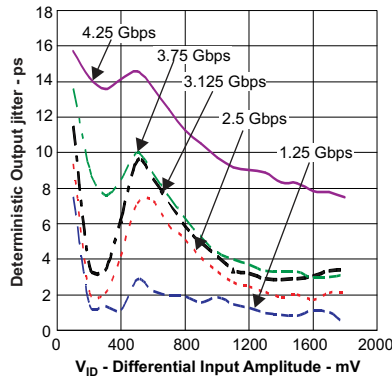

Figure 13.

DIFFERENTIAL OUTPUT VOLTAGE vs DATA RATE

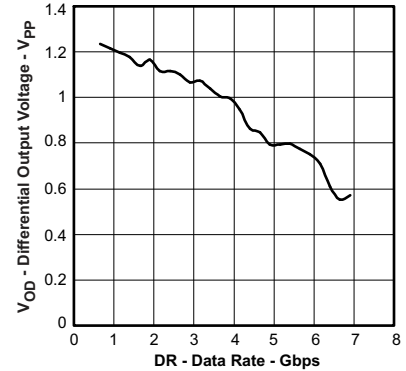

Figure 14.

SUPPLY NOISE vs DETERMINISTIC JITTER vs DATA RATE

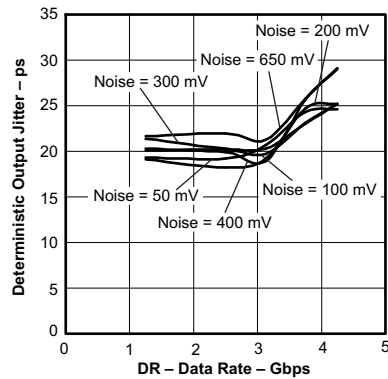

Figure 15.

DETERMINISTIC OUTPUT JITTER vs COMMON-MODE INPUT VOLTAGE

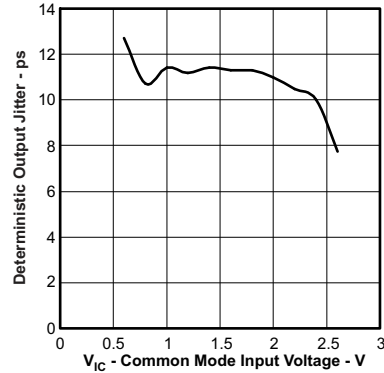

Figure 16.

APPLICATION INFORMATION

CONFIGURATION EXAMPLES

| S10 | S11 | S20 | S21 |
|-----|-----|-----|-----|
| 0 | 0 | 0 | 1 |
| S30 | S31 | S40 | S41 |
| 1 | 0 | 1 | 1 |

| S10 | S11 | S20 | S21 |
|-----|-----|-----|-----|
| 0 | 0 | 0 | 0 |
| S30 | S31 | S40 | S41 |
| 0 | 0 | 0 | 0 |

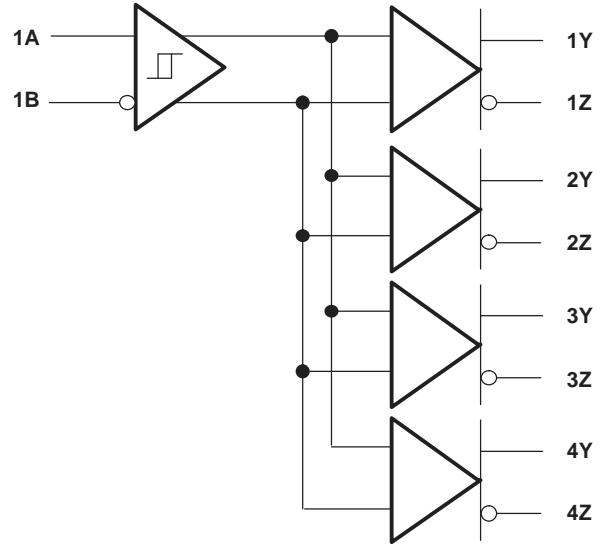
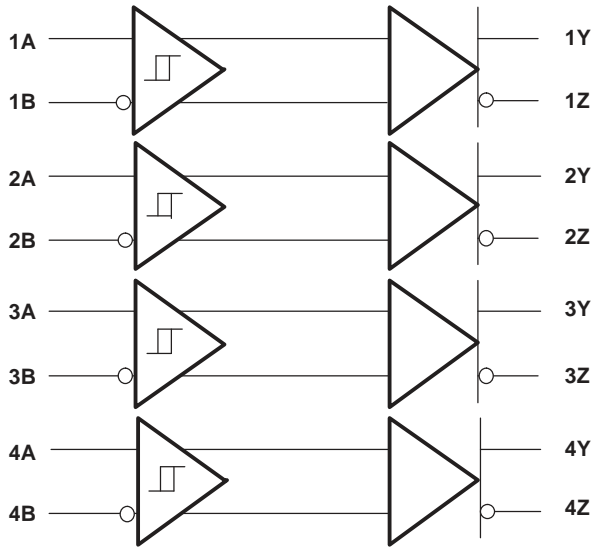

| S10 | S11 | S20 | S21 |
|-----|-----|-----|-----|
| 0 | 0 | 0 | 0 |
| S30 | S31 | S40 | S41 |
| 1 | 0 | 1 | 0 |

| S10 | S11 | S20 | S21 |
|-----|-----|-----|-----|
| 1 | 1 | 1 | 1 |
| S30 | S31 | S40 | S41 |
| 0 | 0 | 0 | 0 |

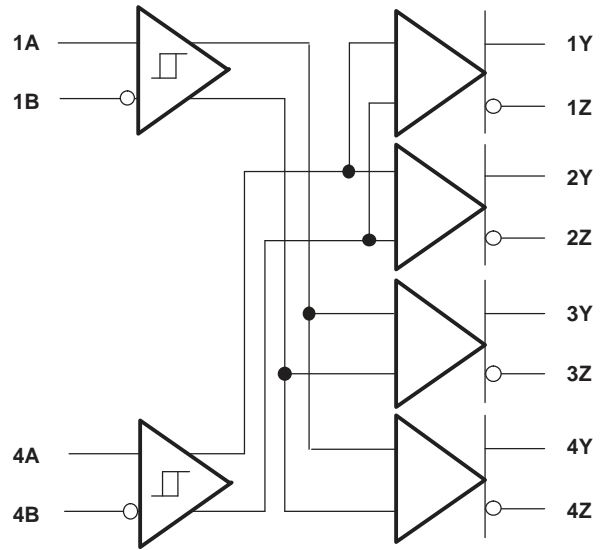
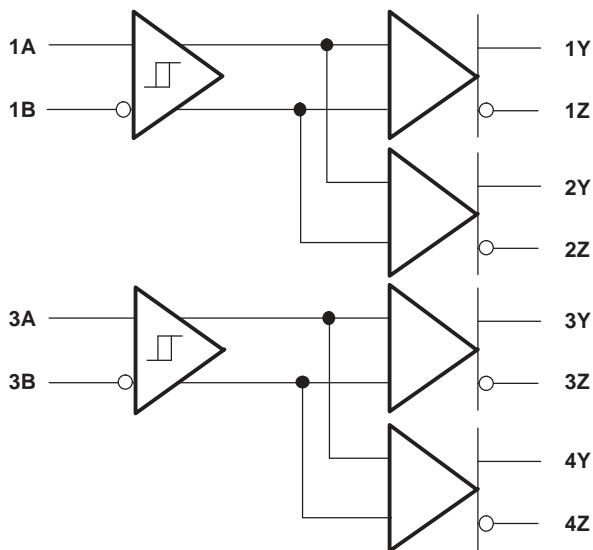

BANDWIDTH REQUIREMENTS

Error free transmission of data over a transmission line has specific bandwidth demands. It is helpful to analyze the frequency spectrum of the transmit data first. For an 8B10B coded data stream at 3.75 Gbps of random data, the highest bit transition density occurs with a 1010 pattern (1.875 GHz). The least transition density in 8B10B allows for five consecutive ones or zeros. Hence, the lowest frequency of interest is $1.875 \text{ GHz}/5 = 375 \text{ MHz}$. Real data signals consist of higher frequency components than sine waves due to the fast rise time. The faster the rise time, the more bandwidth becomes required. For 80-ps rise time, the highest important frequency component is at least $0.6/(\pi \times 80 \text{ ps}) = 2.4 \text{ GHz}$. Figure 17 shows the Fourier transformation of the 375-MHz and 1.875-GHz trapezoidal signal.

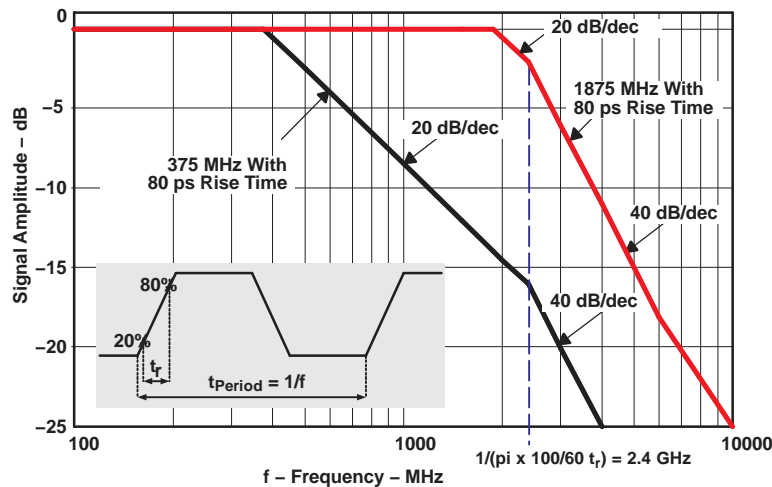

Figure 17. Approximate Frequency Spectrum of the Transmit Output Signal With 80 ps Rise Time

The spectrum analysis of the data signal suggests building a backplane with little frequency attenuation up to 2 GHz. Practically, this is achievable only with expensive, specialized PCB material. To support material like FR4, a compensation technique is necessary to compensate for backplane imperfections.

EXPLANATION OF EQUALIZATION

Backplane designs differ widely in size, layer stack-up, and connector placement. In addition, the performance is impacted by trace architecture (trace width, coupling method) and isolation from adjacent signals. Common to most commercial backplanes is the use of FR4 as board material and its related high-frequency signal attenuation. Within a backplane, the shortest to longest trace lengths differ substantially – often ranging from 8 inches up to 40 inches. Increased loss is associated with longer signal traces. In addition, the backplane connector often contributes a good amount of signal attenuation. As a result, the frequency signal attenuation for a 300-MHz signal might range from 1 dB to 4 dB while the corresponding attenuation for a 2-GHz signal might span 6 dB to 24 dB. This frequency dependent loss causes distortion jitter on the transmitted signal. Each LVCP404 receiver input incorporates an equalizer and compensates for such frequency loss. The SN65LVCP404 equalizer provides 5 dB of frequency gain between 375 MHz and 1.875 GHz, compensating roughly for 20 inches of FR4 material with 8-mil trace width. Distortion jitter improvement is substantial, often providing more than 30-ps jitter reduction. The 5-dB compensation is sufficient for most short backplane traces. For longer trace lengths, it is recommended to enable transmit preemphasis in addition.

SETTING THE PREAMPHASIS LEVEL

The receive equalization compensates for ISI. This reduces jitter and opens the data eye. In order to find the best preemphasis setting for each link, calibration of every link is recommended. Assuming each link consists of a transmitter (with adjustable pre-emphasis such as LVCP404) and the LVCP404 receiver, the following steps are necessary:

1. Set the transmitter and receiver to 0-dB preemphasis; record the data eye on the LVCP404 receiver output.
2. Increase the transmitter preemphasis until the data eye on the LVCP404 receiver output looks the cleanest.

PACKAGING INFORMATION

| Orderable Device | Status (1) | Package Type | Package Drawing | Pins | Package Qty | Eco Plan (2) | Lead finish/ Ball material (6) | MSL Peak Temp (3) | Op Temp (°C) | Device Marking (4/5) | Samples |
|------------------|---------------|--------------|-----------------|------|-------------|-----------------|--------------------------------------|----------------------|--------------|-------------------------|-------------------------|
| SN65LVCP404RGZR | ACTIVE | VQFN | RGZ | 48 | 2500 | RoHS & Green | NIPDAU | Level-3-260C-168 HR | -40 to 85 | LVCP404 | Samples |
| SN65LVCP404RGZT | ACTIVE | VQFN | RGZ | 48 | 250 | RoHS & Green | NIPDAU | Level-3-260C-168 HR | -40 to 85 | LVCP404 | Samples |

(1) The marketing status values are defined as follows:

ACTIVE: Product device recommended for new designs.

LIFEBUY: TI has announced that the device will be discontinued, and a lifetime-buy period is in effect.

NRND: Not recommended for new designs. Device is in production to support existing customers, but TI does not recommend using this part in a new design.

PREVIEW: Device has been announced but is not in production. Samples may or may not be available.

OBSOLETE: TI has discontinued the production of the device.

(2) **RoHS:** TI defines "RoHS" to mean semiconductor products that are compliant with the current EU RoHS requirements for all 10 RoHS substances, including the requirement that RoHS substance do not exceed 0.1% by weight in homogeneous materials. Where designed to be soldered at high temperatures, "RoHS" products are suitable for use in specified lead-free processes. TI may reference these types of products as "Pb-Free".

RoHS Exempt: TI defines "RoHS Exempt" to mean products that contain lead but are compliant with EU RoHS pursuant to a specific EU RoHS exemption.

Green: TI defines "Green" to mean the content of Chlorine (Cl) and Bromine (Br) based flame retardants meet JS709B low halogen requirements of <=1000ppm threshold. Antimony trioxide based flame retardants must also meet the <=1000ppm threshold requirement.

(3) MSL, Peak Temp. - The Moisture Sensitivity Level rating according to the JEDEC industry standard classifications, and peak solder temperature.

(4) There may be additional marking, which relates to the logo, the lot trace code information, or the environmental category on the device.

(5) Multiple Device Markings will be inside parentheses. Only one Device Marking contained in parentheses and separated by a "~" will appear on a device. If a line is indented then it is a continuation of the previous line and the two combined represent the entire Device Marking for that device.

(6) Lead finish/Ball material - Orderable Devices may have multiple material finish options. Finish options are separated by a vertical ruled line. Lead finish/Ball material values may wrap to two lines if the finish value exceeds the maximum column width.

Important Information and Disclaimer:The information provided on this page represents TI's knowledge and belief as of the date that it is provided. TI bases its knowledge and belief on information provided by third parties, and makes no representation or warranty as to the accuracy of such information. Efforts are underway to better integrate information from third parties. TI has taken and continues to take reasonable steps to provide representative and accurate information but may not have conducted destructive testing or chemical analysis on incoming materials and chemicals. TI and TI suppliers consider certain information to be proprietary, and thus CAS numbers and other limited information may not be available for release.

In no event shall TI's liability arising out of such information exceed the total purchase price of the TI part(s) at issue in this document sold by TI to Customer on an annual basis.

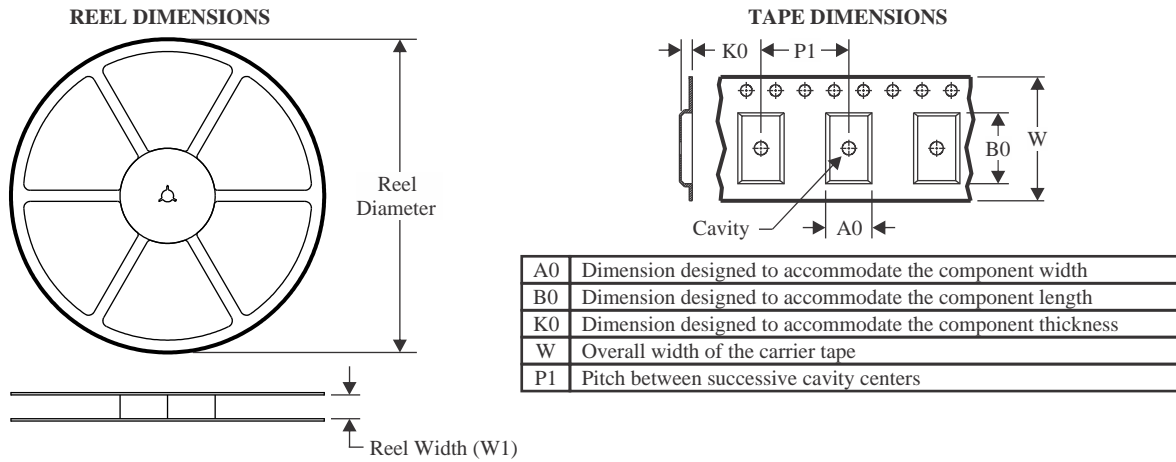
TAPE AND REEL INFORMATION

QUADRANT ASSIGNMENTS FOR PIN 1 ORIENTATION IN TAPE

*All dimensions are nominal

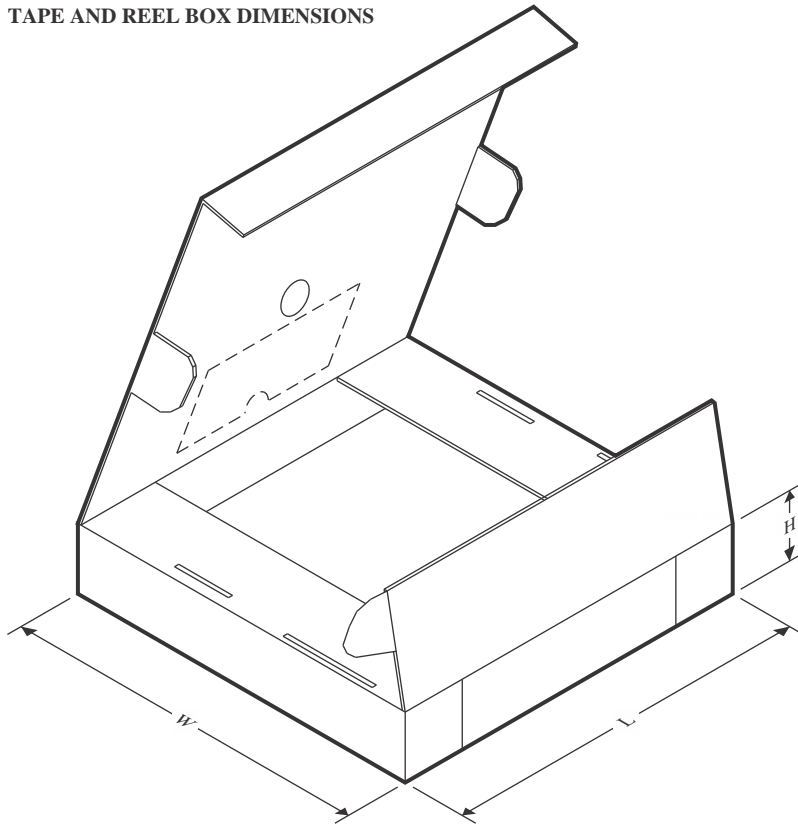
| Device | Package Type | Package Drawing | Pins | SPQ | Reel Diameter (mm) | Reel Width W1 (mm) | A0 (mm) | B0 (mm) | K0 (mm) | P1 (mm) | W (mm) | Pin1 Quadrant |
|-----------------|--------------|-----------------|------|------|--------------------|--------------------|---------|---------|---------|---------|--------|---------------|
| SN65LVCP404RGZR | VQFN | RGZ | 48 | 2500 | 330.0 | 16.4 | 7.3 | 7.3 | 1.5 | 12.0 | 16.0 | Q2 |
| SN65LVCP404RGZT | VQFN | RGZ | 48 | 250 | 180.0 | 16.4 | 7.3 | 7.3 | 1.5 | 12.0 | 16.0 | Q2 |

TAPE AND REEL BOX DIMENSIONS

*All dimensions are nominal

| Device | Package Type | Package Drawing | Pins | SPQ | Length (mm) | Width (mm) | Height (mm) |
|-----------------|--------------|-----------------|------|------|-------------|------------|-------------|
| SN65LVCP404RGZR | VQFN | RGZ | 48 | 2500 | 356.0 | 356.0 | 35.0 |
| SN65LVCP404RGZT | VQFN | RGZ | 48 | 250 | 210.0 | 185.0 | 35.0 |

GENERIC PACKAGE VIEW

RGZ 48

VQFN - 1 mm max height

7 x 7, 0.5 mm pitch

PLASTIC QUADFLAT PACK- NO LEAD

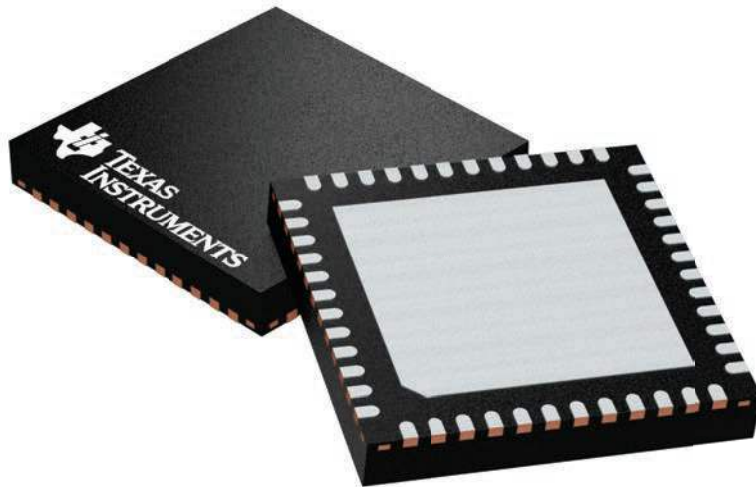

Images above are just a representation of the package family, actual package may vary.
Refer to the product data sheet for package details.

4224671/A

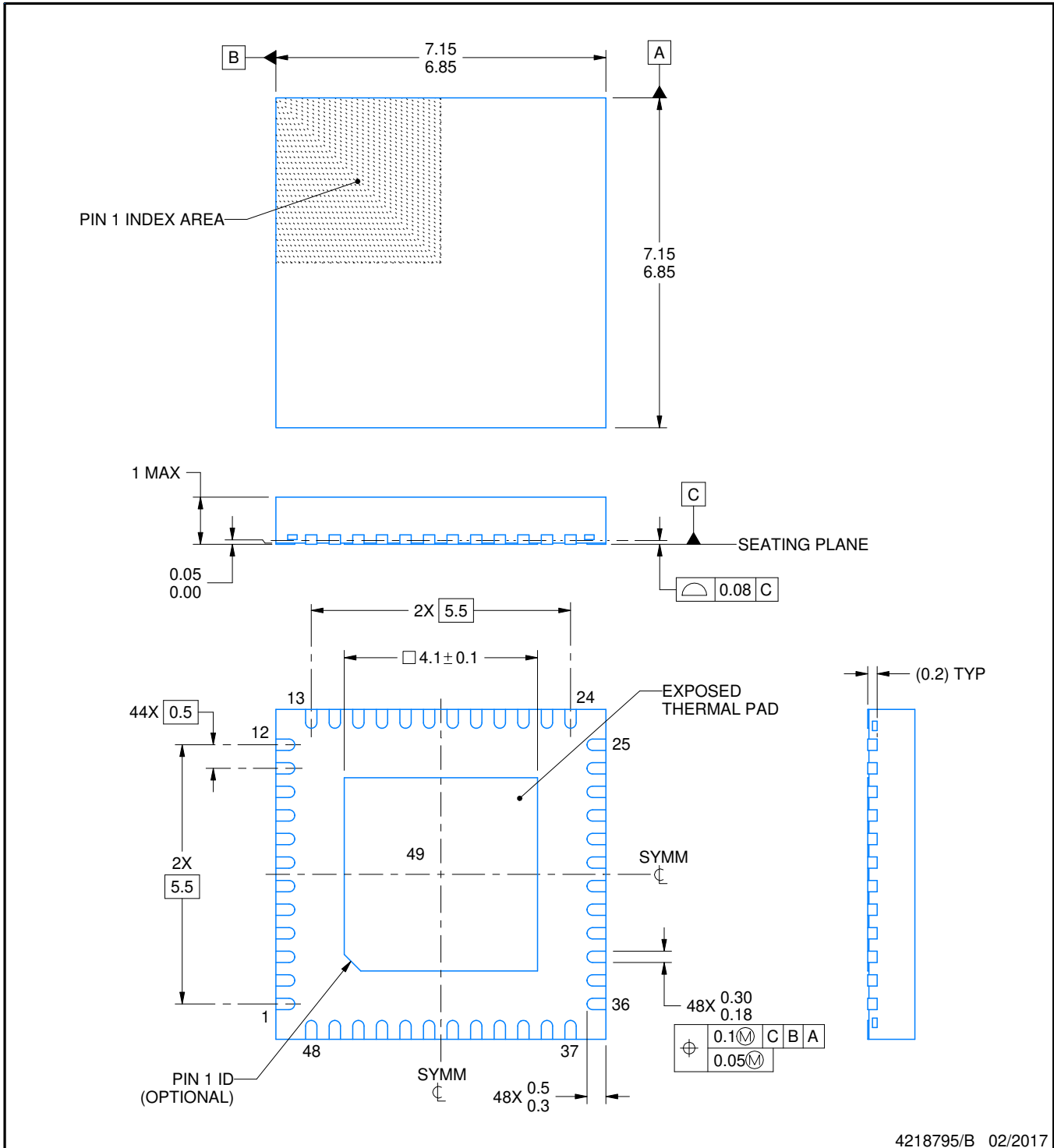
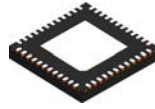

4218795/B 02/2017

NOTES:

1. All linear dimensions are in millimeters. Any dimensions in parenthesis are for reference only. Dimensioning and tolerancing per ASME Y14.5M.
2. This drawing is subject to change without notice.
3. The package thermal pad must be soldered to the printed circuit board for thermal and mechanical performance.

EXAMPLE BOARD LAYOUT

RGZ0048B

VQFN - 1 mm max height

PLASTIC QUAD FLATPACK - NO LEAD

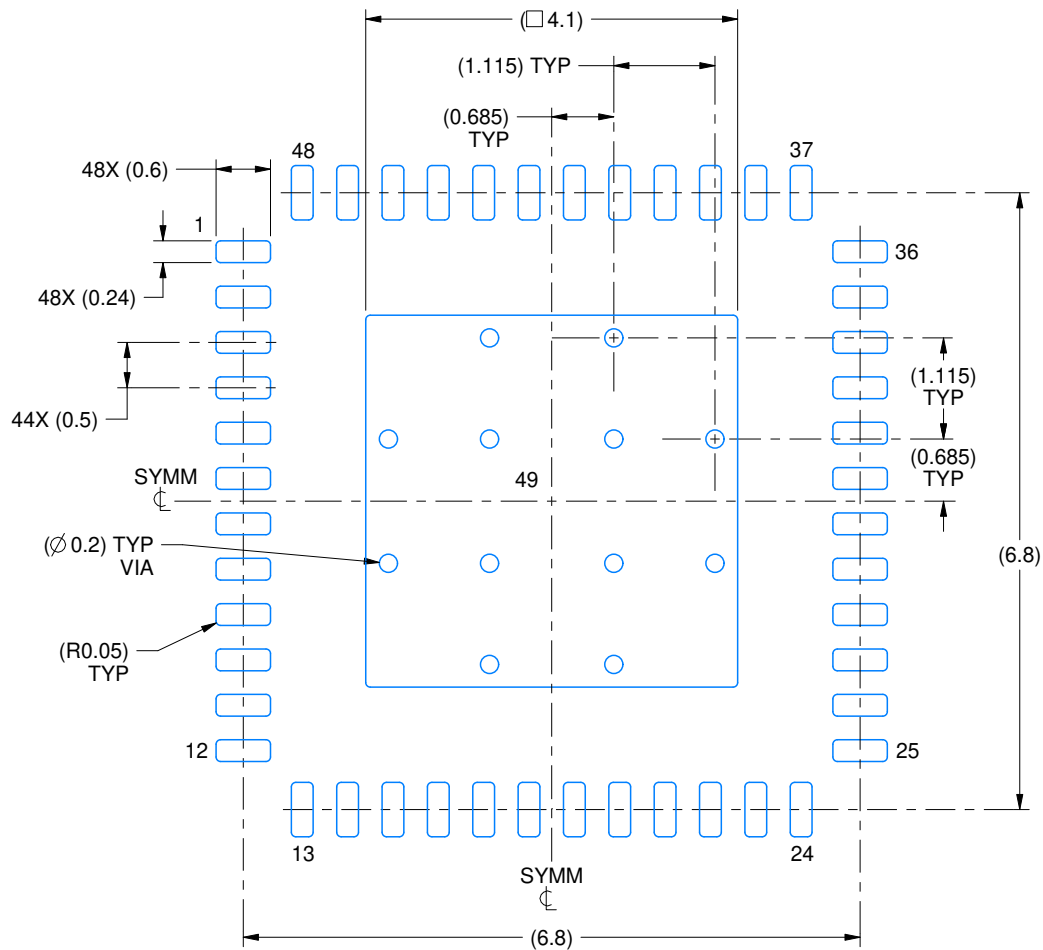

LAND PATTERN EXAMPLE
EXPOSED METAL SHOWN
SCALE:12X

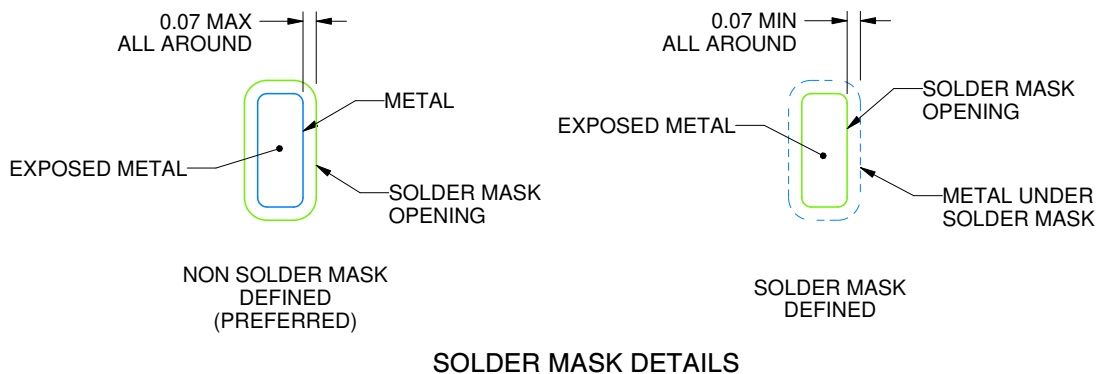

SOLDER MASK DETAILS

4218795/B 02/2017

NOTES: (continued)

4. This package is designed to be soldered to a thermal pad on the board. For more information, see Texas Instruments literature number SLUA271 (www.ti.com/lit/slua271).
5. Vias are optional depending on application, refer to device data sheet. If any vias are implemented, refer to their locations shown on this view. It is recommended that vias under paste be filled, plugged or tented.

EXAMPLE STENCIL DESIGN

RGZ0048B

VQFN - 1 mm max height

PLASTIC QUAD FLATPACK - NO LEAD

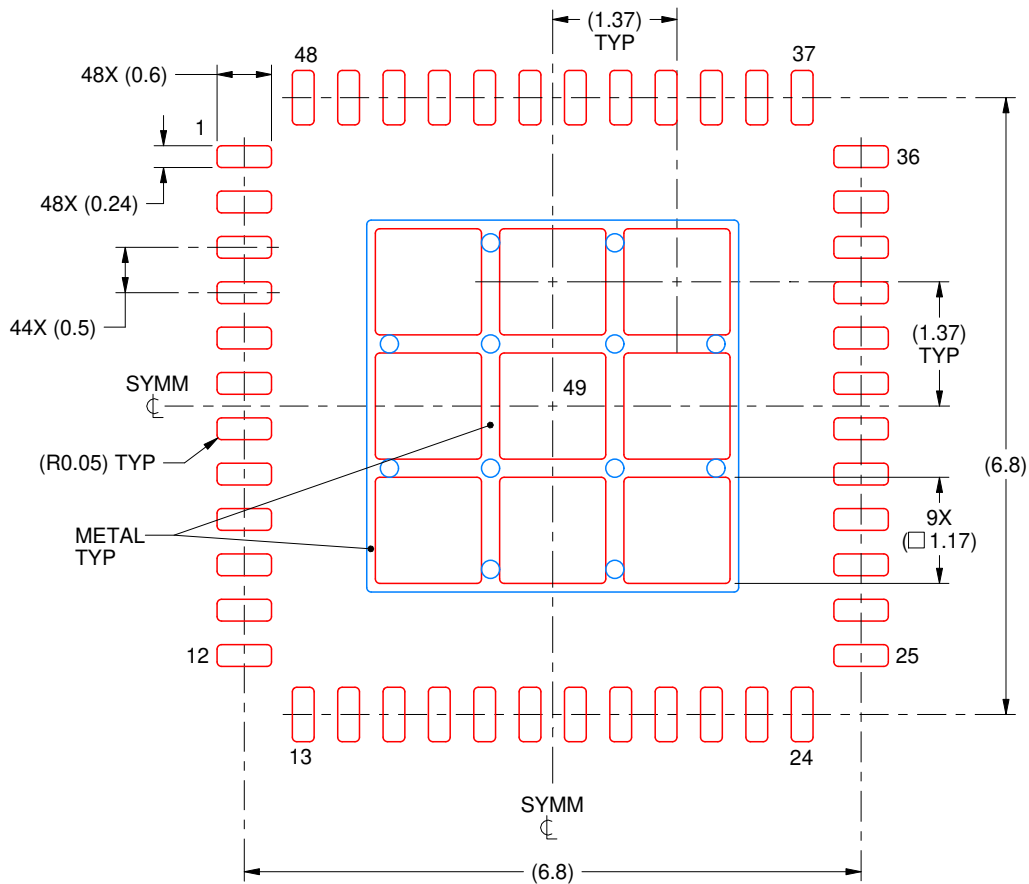

SOLDER PASTE EXAMPLE
 BASED ON 0.125 mm THICK STENCIL

EXPOSED PAD 49
 73% PRINTED SOLDER COVERAGE BY AREA UNDER PACKAGE
 SCALE:12X

4218795/B 02/2017

NOTES: (continued)

- 6. Laser cutting apertures with trapezoidal walls and rounded corners may offer better paste release. IPC-7525 may have alternate design recommendations.

IMPORTANT NOTICE AND DISCLAIMER

TI PROVIDES TECHNICAL AND RELIABILITY DATA (INCLUDING DATA SHEETS), DESIGN RESOURCES (INCLUDING REFERENCE DESIGNS), APPLICATION OR OTHER DESIGN ADVICE, WEB TOOLS, SAFETY INFORMATION, AND OTHER RESOURCES "AS IS" AND WITH ALL FAULTS, AND DISCLAIMS ALL WARRANTIES, EXPRESS AND IMPLIED, INCLUDING WITHOUT LIMITATION ANY IMPLIED WARRANTIES OF MERCHANTABILITY, FITNESS FOR A PARTICULAR PURPOSE OR NON-INFRINGEMENT OF THIRD PARTY INTELLECTUAL PROPERTY RIGHTS.

These resources are intended for skilled developers designing with TI products. You are solely responsible for (1) selecting the appropriate TI products for your application, (2) designing, validating and testing your application, and (3) ensuring your application meets applicable standards, and any other safety, security, regulatory or other requirements.

These resources are subject to change without notice. TI grants you permission to use these resources only for development of an application that uses the TI products described in the resource. Other reproduction and display of these resources is prohibited. No license is granted to any other TI intellectual property right or to any third party intellectual property right. TI disclaims responsibility for, and you will fully indemnify TI and its representatives against, any claims, damages, costs, losses, and liabilities arising out of your use of these resources.

TI's products are provided subject to [TI's Terms of Sale](#) or other applicable terms available either on ti.com or provided in conjunction with such TI products. TI's provision of these resources does not expand or otherwise alter TI's applicable warranties or warranty disclaimers for TI products.

TI objects to and rejects any additional or different terms you may have proposed.

Mailing Address: Texas Instruments, Post Office Box 655303, Dallas, Texas 75265
Copyright © 2022, Texas Instruments Incorporated