

NOTE: (B4)

SUITABLE FOR RT360 SERIES 1403 AND 1604 LAYOUT CONNECTOR

REVISIONS					
REV	ECO	DESCRIPTION	DATE	BY	APPR
B1	-	RELEASED DRAWING	JUN-17-2014	BEN	TOMMY
B2	-	DESIGN CHANGE	JUL-18-2017	FLAN	TOMMY
B3	-	Add the note	Sep-14-21	Flan	Tommy

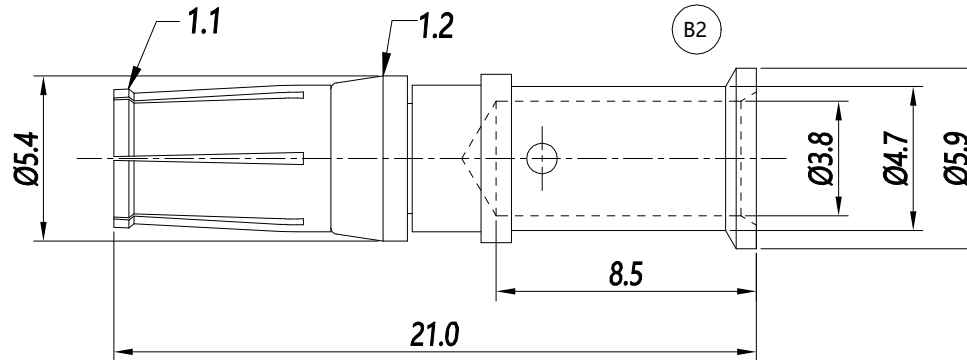

NOTES: (UNLESS OTHERWISE SPECIFIED)

- MATERIAL:
 - CONTACT BODY: COPPER ALLOY.
 - POSITIONING CLIP: COPPER ALLOY.
- SPECIFICATIONS:
 - CURRENT RATING: 45A(MAX).
 - TERMINATION TYPE: CRIMPING.
 - WIRE RANGE: 10~12AWG.
- SUITABLE CONTACT: MP10A23xx .
- RoHS COMPLIANT.
- ALL DIMENSIONS ARE FOR REFERENCE USE ONLY.

P/N	CONTACT PLATING(MATING AREA)
MS10A23T	TIN PLATING OVER NICKEL.
MS10A23S	SILVER PLATING OVER NICKEL.
MS10A23F	GOLD FLASH PLATING OVER NICKEL.
MS10A23G5	5μ"GOLD PLATING OVER NICKEL.
MS10A23G10	10μ"GOLD PLATING OVER NICKEL.
MS10A23G15	15μ"GOLD PLATING OVER NICKEL.
MS10A23G30	30μ"GOLD PLATING OVER NICKEL.

QUANTITY	PART NUMBER	DESCRIPTION	ITEM
MATERIALS LIST			
UNLESS OTHERWISE SPECIFIED 1) All dimensions are in metric(mm). 2) Tolerances are as follows: 1 PL DEC ±0.30 2 PL DEC ±0.15 3 PL DEC ±0.08 Fractions ±1/64 Angles ±1° 3) Note reference =		SIGNATURES DATE DRAWN: Flan Sep-14-21 CHECKED: Orion Sep-15-21 ENGINEER: APPROVAL: Tommy Sep-15-21 CUSTOMER:	 Sine Systems - www.amphenol-sine.com 44724 Morley Drive Clinton Township, MI 48036
MATERIAL SPECIFICATIONS:		EcoMate RM, SOCKET CONTACT, MACHINE, FEMALE CONTACT, 3.6mm	
PROCESS SPECIFICATIONS:		THIS DRAWING IS SUPPLIED FOR INFORMATION ONLY. DESIGN FEATURES, SPECIFICATIONS AND PERFORMANCE DATA SHOWN HEREON ARE THE PROPERTY OF THE AMPHENOL CORPORATION. NO RIGHTS OF REPRODUCTION ARE IMPLIED. ALL DIMENSIONS ARE SUBJECT TO NORMAL MANUFACTURING VARIATIONS.	
NEXT ASSY:	SCALE: NONE	SIZE: B TYPE: C- DWG NO: MS10A23xx REVISION: B3 SHEET 1 OF 1	

TITLE: EcoMate RM, SOCKET CONTACT, MACHINE CONTACT, 3.6mm
 DWG NO: MS10A23xx
 REV: B3
 SH: 1
 OF: 1