

Evaluating the **ADM1293** and **ADM1294** Digital Power Monitors

FEATURES

Full featured evaluation kits for **ADM1293** and **ADM1294**
 I²C/PMBus interface supports all product-related software
 Supports bidirectional current emulation
 Multiboard cascade support

EVALUATION KIT CONTENTS

8-way, 150 mm Micromatch ribbon cable
 For **EVAL-ADM1294EBZ** only:
EVAL-ADM3260MEBZ
 10-way, 150 mm Micromatch ribbon cable

ADDITIONAL EQUIPMENT NEEDED

USB-to-I²C dongle **USB-SDP-CABLEZ**
 Power supply
 Electronic load (optional)

RELATED DOCUMENTS

ADM1293 and **ADM1294** data sheets
EVAL-ADM3260MEBZ user guide

SOFTWARE NEEDED

Hot swap and power monitoring evaluation software
 available on the **ADM1293** and **ADM1294** product pages

GENERAL DESCRIPTION

This user guide describes how to use the **ADM1293** and **ADM1294** evaluation kits. The kits provide all of the support circuitry required to operate the **ADM1293** and **ADM1294** (in their various modes and configurations, including multiple board setups). The **ADM1293** and **ADM1294** data sheets, available at www.analog.com, provide additional information, and should be consulted when using the evaluation board. All documents and software tools are available at www.analog.com/power-management.

Note that **USB-SDP-CABLEZ** is not included in the evaluation kit and should be ordered separately. Only one dongle is required in multiboard cascade setup. One device socket is included in each kit.

EVALUATION BOARD PHOTOGRAPHS

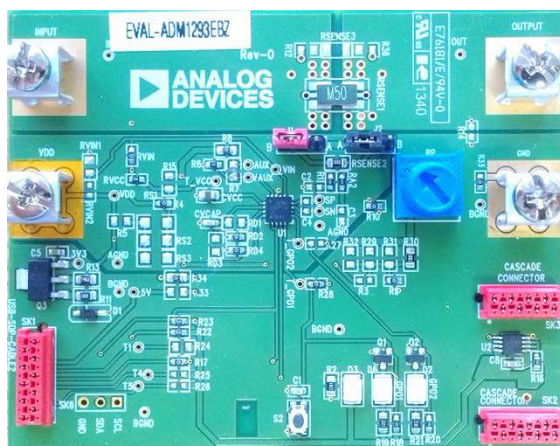

Figure 1. **ADM1293** Evaluation Board

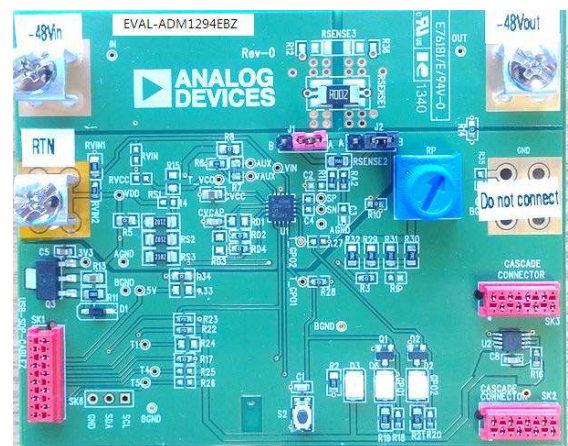

Figure 2. **ADM1294** Evaluation Board

TABLE OF CONTENTS

Features	1	Power Supply and Load Connection	3
Evaluation Kit Contents.....	1	Current Emulation	4
Additional Equipment Needed	1	I ² C/PMBus Interface.....	4
Related Documents	1	Multiple Board Setup	5
Software Needed	1	Add Isolation to the Communicaiton Interface.....	5
General Description	1	Switch and LED Functions.....	5
Evaluation Board Photographs	1	Evaluation Board Schematics and Artwork.....	6
Revision History	2	Ordering Information.....	8
Evaluation Board Hardware.....	3	Bill of Materials.....	8

REVISION HISTORY

9/14—Revision 0: Initial Version

EVALUATION BOARD HARDWARE

The EVAL-ADM1293EBZ and EVAL-ADM1294EBZ boards are designed for user evaluation of ADM1293 and ADM1294 digital power monitor ICs.

Both evaluation kits are based on the same PCB design with different component and configurations. The board is simple to use, easy to probe, allows flexible wiring, and offers multiple board cascadability.

POWER SUPPLY AND LOAD CONNECTION

The recommended power supply and load connection for the evaluation boards is illustrated in Figure 3 and Figure 4.

The ADM1293 power monitor is designed to operate with supply from 2.95 V to 20 V and can monitor supplies from 0 V to 20 V. The common-mode voltage of the monitoring supply needs to be equal or less than the chip supply VCC. The user can choose to unpopulate RVCC and use the VAUX terminal for IC supply biasing to monitor a supply rail lower than 2.95 V. The evaluation board uses a simple regulator to generate 3.3 V to power a few on-board components. It is recommended to

keep the ADM1293 evaluation board supply above 5 V to keep the devices such as on-board EEPROM powered. The on-board EEPROM is used to store evaluation board information such as board type, sense resistor, and divider values. The 0.5 mΩ sense resistor allows maximum current sensing range around ±50 A with 25 mV sense voltage range selected. Higher current sensing range is possible by selecting higher sense voltage range, but the user needs to be aware of the power dissipated in the sense resistor.

The ADM1294 is designed for low side monitoring and with its integrated shunt resistor it can be powered from high voltage supplies with a wide voltage range. The ADM1294 evaluation board is designed to be powered from a 48 V (or -48 V depending on the referencing point) rail and monitors its power. The 2 mΩ sense resistor allows maximum current sensing range around ±12.5 A with 25 mV sense voltage range selected.

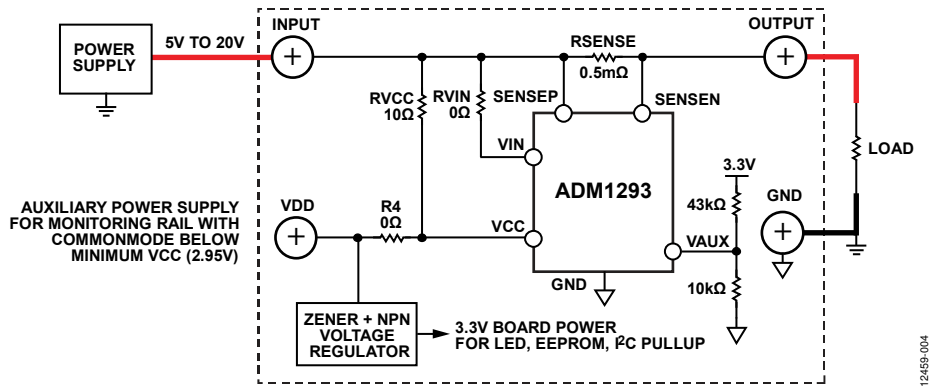

Figure 3. Power Supply And Load Connection For ADM1293 Evaluation Board

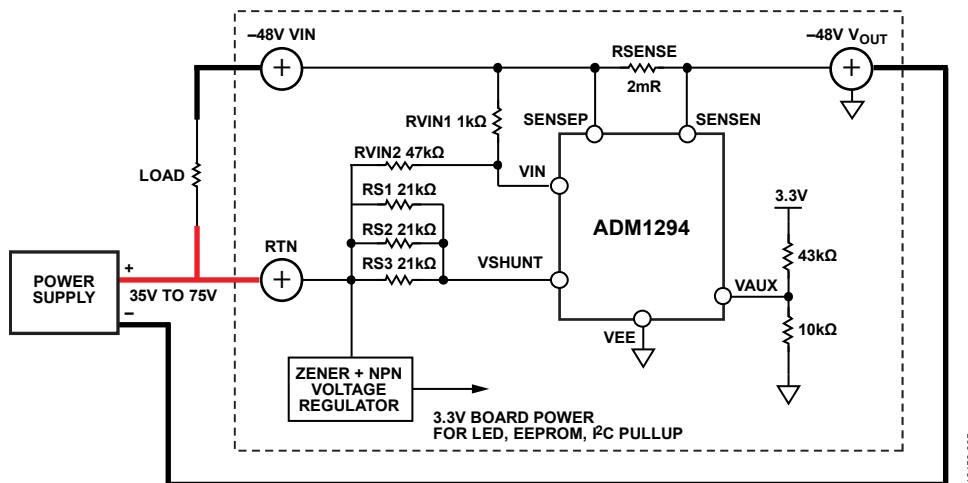

Figure 4. Power Supply And Load Connection For ADM1294 Evaluation Board

CURRENT EMULATION

A simple current emulation circuit is building to the evaluation board to allow use to emulate the current readback without the need of connecting load to the board.

The circuit injects current from the board supply to a dummy sense resistor sitting across the IC sense pins, generating voltage drop across the sense pins, which emulates a current reading.

The user can adjust the level of emulated current by tweaking the knob of the potentiometer in series. A pair of jumpers allows the user to configure the emulation circuit into positive current emulation, negative current emulation, and disable mode.

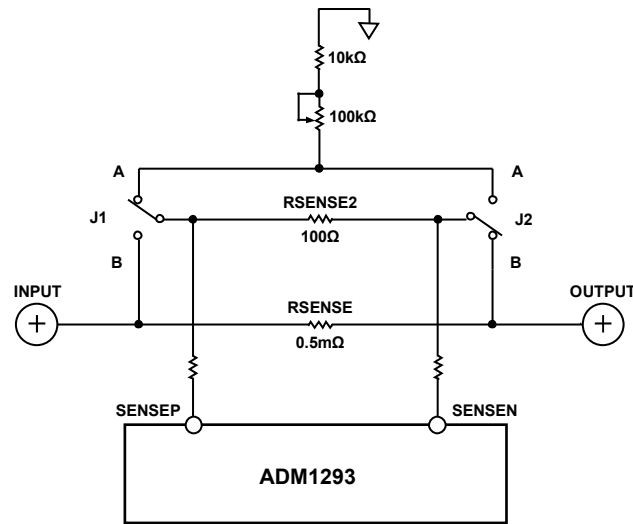

Figure 5. ADM1293 Evaluation Board Current Emulation Circuit

Table 1. Current Emulation Circuit Jumper Configuration for ADM1293 Evaluation Board

J1	J2	Description
B	B	Current emulation disabled, the ADM1293 senses current flow from the INPUT terminal to the OUTPUT terminal ¹
A	B	Negative current emulation mode
B	A	Positive current emulation mode
A	A	Not used

¹ In this mode, the primary sense resistor is in parallel with the dummy sense resistor, because the resistance value of the dummy resistor is much larger than the primary one, the resulted resistance is very close to the primary sense resistor value.

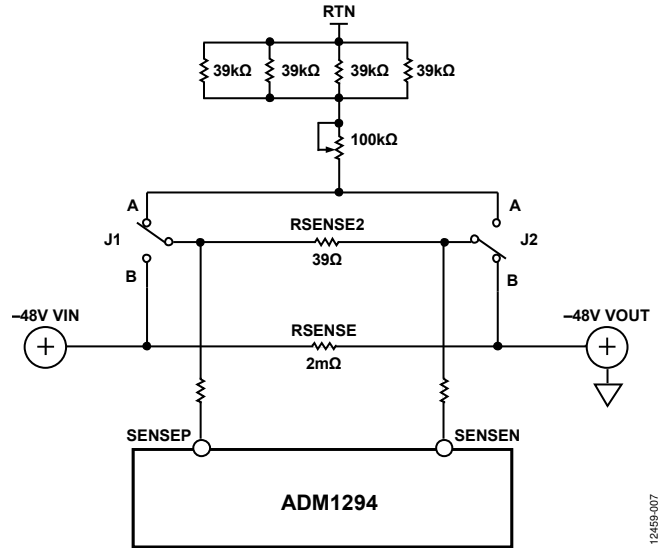

Figure 6. ADM1294 Evaluation Board Current Emulation Circuit

Table 2. Current Emulation Circuit Jumper Configuration for ADM1294 Evaluation Board

J1	J2	Description
B	B	Current emulation disabled, the ADM1294 senses current flow from -48V VIN terminal to -48V VOUT terminal
A	B	Positive current emulation mode
B	A	Negative current emulation mode
A	A	Not used

I²C/PMBUS INTERFACE

The evaluation boards support an I²C interface. The user can connect from the PC USB port to the board using the [USB-SDP-CABLEZ](#) dongle from Analog Devices, Inc. The dongle has internal pull-ups for the SDA and SCL bus. Users can use their own I²C cable. The evaluation board can provide on-board 3.3 V voltage pull-up by populating corresponding pull-up resistors.

Though not included in the evaluation kit, the [USB-SDP-CABLEZ](#) USB-to-serial-I/O interface is required to connect evaluation boards to a PC to allow control and monitoring by the evaluation software.

The board is compatible with hot-swap and power monitoring evaluation software from Analog Devices.



Figure 7. USB-SDP-CABLEZ USB-to-Serial-I/O Interface

MULTIPLE BOARD SETUP

Connector SK2 and Connector SK3, along with the eight-way ribbon cable, allow multiple EVAL-ADM1293EBZ and EVAL-ADM1294EBZ boards to be connected together for evaluating multirail monitoring setup.

The connection cable carries I²C communication signals across every board that is connected. The user only needs to connect the I²C cable to one board. Due to the fact all of the evaluation boards are configured with the same I²C address, the user needs to change the address pin configuration for ADM1293 or ADM1294 to differentiate them on the bus.

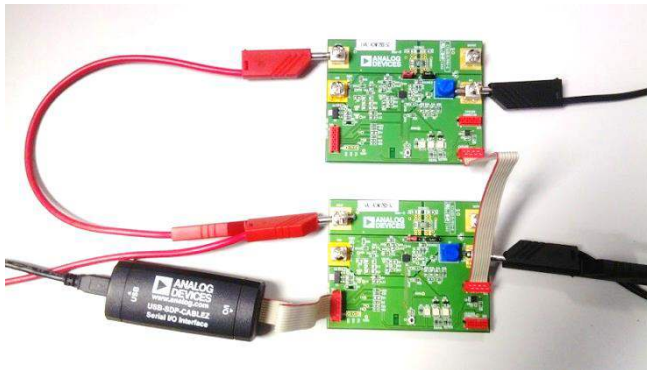

Figure 8. Multiple Boards Connection

ADD ISOLATION TO THE COMMUNICAITON INTERFACE

With the low side sensing and integrated shunt regulator, the ADM1294 is an ideal candidate for high voltage rail monitoring. The EVAL-ADM1294EBZ kit is designed to monitor -48 V rail to demonstrate the IC’s capability. The user can easily evaluate the setup by powering the board using a +48 V supply. In the case where users want to connect the board to their actual system to monitor the true -48 V rail input, take caution to isolate the communication lines between the board and the PC/user for functional and safety reasons.

To help users achieve this isolation, Analog Devices has designed a simple isolation board with the ADM3260 digital signal and power isolator IC. The EVAL-ADM3260MEBZ board can be easily inserted between the USB-SDP-CABLEZ dongle and the ADM1293 or ADM1294 evaluation board to provide 2.5 kV isolation between the two.

The EVAL-ADM3260MEBZ and the additional connector comes with each EVAL-ADM1294EBZ kit by default. For more information about the EVAL-ADM3260MEBZ kit, refer to EVAL-ADM3260MEBZ user guide.

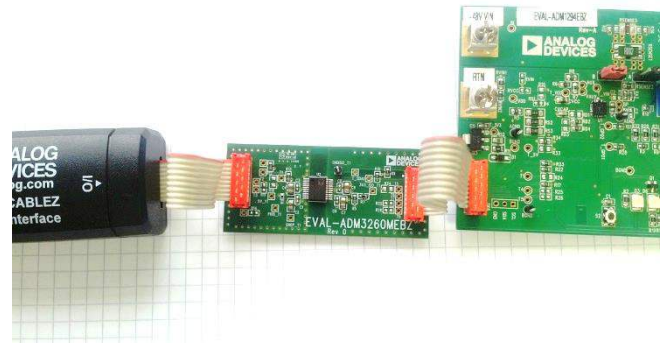

Figure 9. EVAL-ADM3260MEBZ Connection



Figure 10. EVAL-ADM3260MEBZ Connection Block Diagram

SWITCH AND LED FUNCTIONS

Table 3. Switch Functions

Switch	Description
S2	Push button switch connected to GPO1/ALERT1/CONV pin of the device. With the pin configured to CONV mode, this switch can be used to generate a signal to control when a power monitor ADC sampling cycle begins.

Table 4. LED Functions

LED	Description
D3	Power indication LED. On indicates power is present on-board.
D6	GPO1 pin indication LED. Indicates the logic level on GPO1 pin.
D2	GPO2 pin indication LED. Indicates the logic level on GPO2 pin.

EVALUATION BOARD SCHEMATICS AND ARTWORK

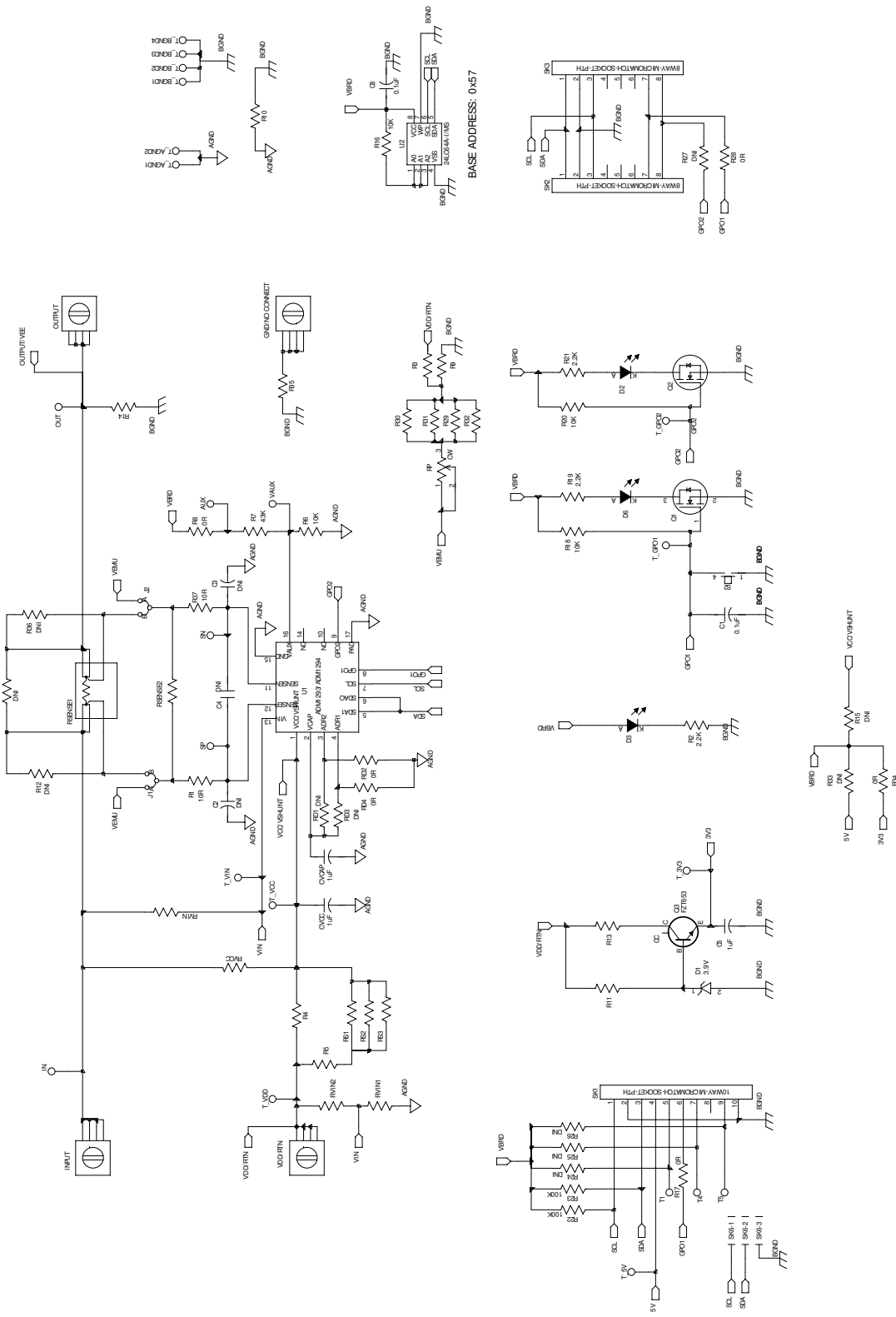

Figure 11. Board Schematic 1

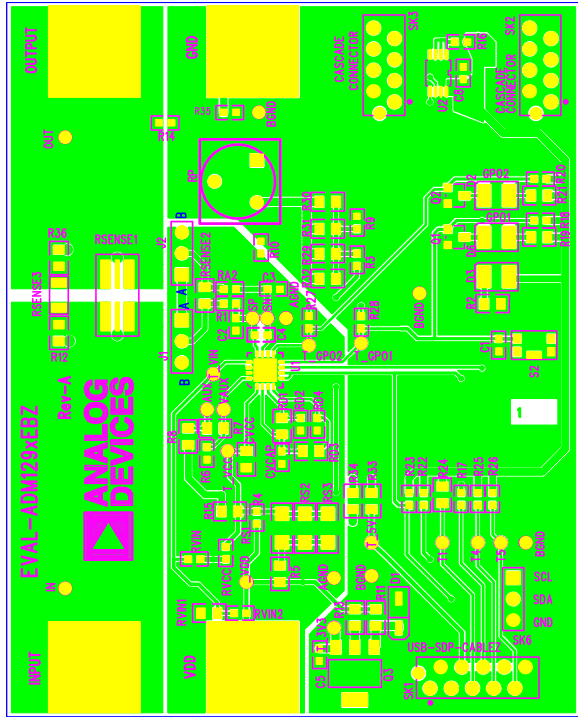

Figure 12. Evaluation Board Layout, Layer 2

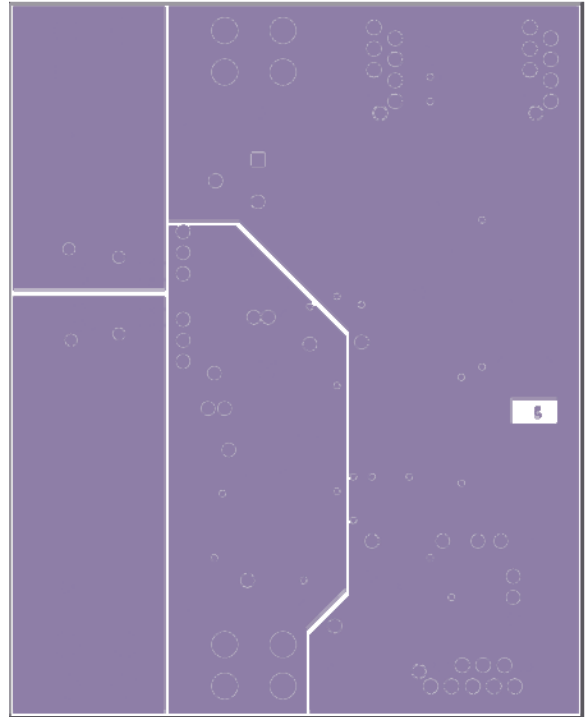

Figure 14. Evaluation Board Layout, Layer 3

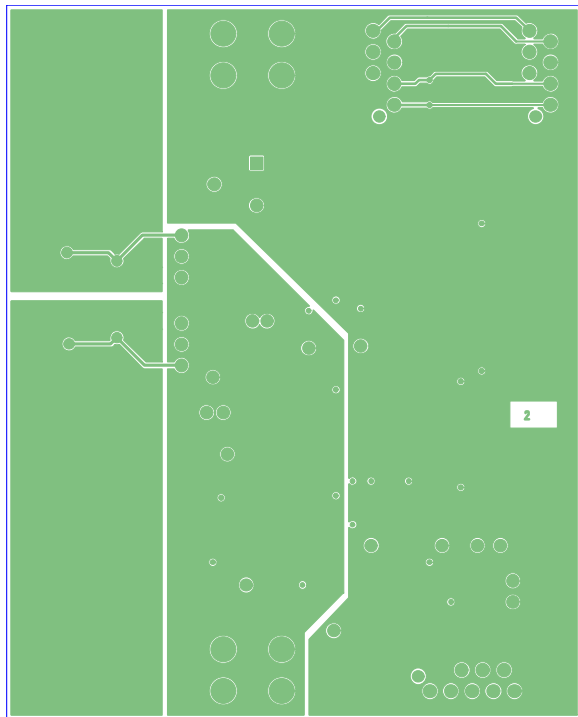

Figure 13. Evaluation Board Layout, Layer 2

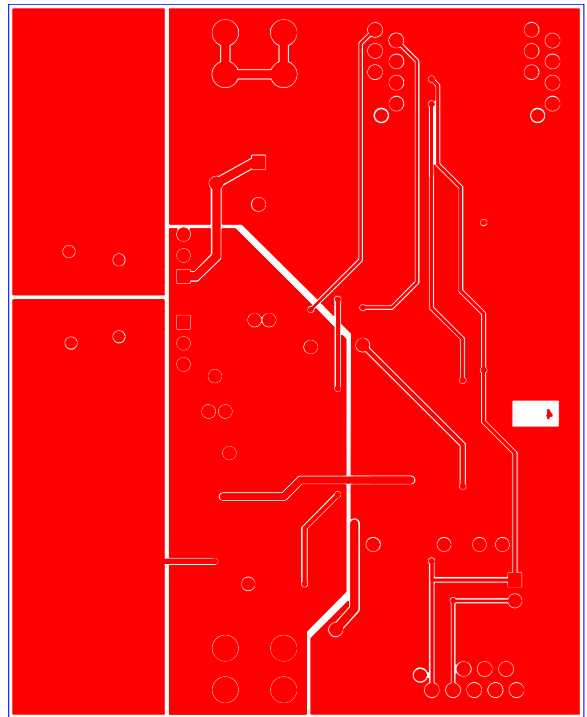

Figure 15. Evaluation Board Layout, Layer 4

ORDERING INFORMATION

BILL OF MATERIALS

Table 5.

Reference Designator	Description	Manufacturer	Part Number	Stock Code
C1	Capacitor, 100 nF, 50 V, X7R, 0603	N/A	C0603C104K5RACTU	FEC 1288255
C2	Capacitor	N/A		DNI
C3	Capacitor	N/A		DNI
C4	Capacitor			DNI
C5	Capacitor 1 μ F, 10 V, X5R, 10%, 0603	Taiyo Yuden	0603ZD105KAT2A	FEC 1327684
C8	Capacitor, 100 nF, 50 V, X7R, 0603	Kemet	C0603C104K5RACTU	FEC 1288255
CVCAP	Capacitor, 1 μ F, 10 V, X5R, 10%, 0603	N/A	0603ZD105KAT2A	FEC 1327684
CVCC	Capacitor, 1 μ F, 25 V, X7R, 0805	Kemet	C0805C105K3RACTU	FEC 1637035
D1	Diode Zener SS 3.9 V 375 MW SOD123F	Vishay	BZT52H-C3V9,115	FEC-1907625
D2	Yellow LED, PLLC		VLMY30J2M1-GS08	FEC 1328365
D3	Green LED, PLLC		VLMC3100-GS08	FEC 1659076
D6	Yellow LED, PLLC		VLMY30J2M1-GS08	FEC 1328365
GND	Terminal screw VERT SNAP-IN PC MNT	Keystone	7691	Digi-Key 7691K-ND (ADM1293)
INPUT	Terminal screw VERT SNAP-IN PC MNT	Keystone	7691	Digi-Key 7691K-ND
J1	3-pin SIL header and shorting link	Harwin	M20-9990345, M7567-05	FEC 1022249, FEC 150-411
J2	3-pin SIL header and shorting link	Harwin	M20-9990345, M7567-05	FEC 1022248, FEC 150410
OUTPUT	Terminal screw VERT SNAP-IN PC MNT	Keystone	7691	Digi-Key 7691K-ND
Q1	MOSFET N-CH 60 V 0.115 A SOT23	Diodes Inc.	2N7002-7-F	FEC 1713823
Q2	MOSFET N-CH 60 V 0.115 A SOT23	Diodes Inc.	2N7002-7-F	FEC 1713823
Q3	NPN transistor	Diodes Inc.	FZT653	FEC 9525017
R1	Resistor, 0603, 0.1 W, 10 Ω	Vishay Draloric	CRCW060310R0FKEA	FEC 1469751
R2	Resistor, power, 0805, 1%, 2.20 k Ω		CRCW08052K20FKEAHP	FEC 1738964
R3	Resistor, 0 Ω , 0603	Vishay Draloric	CRCW06030000Z0EA	DNI (ADM1293) FEC 1469739 (ADM1294)
R4	Resistor, 0 Ω , 0603	N/A	CRCW06030000Z0EA	FEC 1469739 (ADM1293) DNI (ADM1294)
R5	Resistor, 0 Ω , 0603	Vishay Draloric	CRCW06030000Z0EA	DNI (ADM1293) FEC 1469739 (ADM1294)
R6	Resistor, 0603, 1%, 10 k Ω	N/A	CRCW060310K0FKTA	FEC 1652827RL
R7	Resistor, 0603, 43 k Ω	Panasonic	ERJU03F4302V	FEC 2145389
R8	Resistor, 0 Ω , 0603	Vishay Draloric	CRCW06030000Z0EA	FEC 1469739
R9	Resistor, 0 Ω , 0603	Vishay Draloric	CRCW06030000Z0EA	FEC 1469739 (ADM1293) DNI
R10	Resistor, 0 Ω , 0603	Vishay Draloric	CRCW06030000Z0EA	FEC 1469739
R11	Resistor, 0805, 1 k Ω (ADM1293), 5.49 k Ω (ADM1294)		CRCW08051K00FKEAHP (ADM1293), CRCW08055K49FKEA (ADM1294)	FEC 1738959 (ADM1293) FEC 2138962RL (ADM1294)
R12	Resistor	Vishay Draloric		DNI
R13	Resistor, 0805, 5 k Ω (ADM1294), 196 Ω (ADM1293)		RP73PF2A196RBTDF (ADM1293), PNM0805E5001BST5 (ADM1294)	FEC 2117086 (ADM1293) FEC 1857222 (ADM1294)
R14	Resistor, 0 Ω , 0603	Vishay Draloric	CRCW06030000Z0EA	DNI (ADM1293) FEC 1469739 (ADM1294)
R15	Resistor			DNI
R16	Resistor, 0603, 1%, 10 k Ω	Vishay Draloric	CRCW060310K0FKEAHP	FEC 1738918
R17	Resistor, 0 Ω , 0603		CRCW06030000Z0EA	FEC 1469739

Reference Designator	Description	Manufacturer	Part Number	Stock Code
R18	Resistor, 0603, 1%, 10 kΩ	Vishay Draloric	CRCW060310K0FKEAHP	FEC 1738918
R19	Resistor, power, 0805, 1%, 2.20 kΩ	Vishay Draloric	CRCW08052K20FKEAHP	FEC 1738964
R20	Resistor, 0603, 1%, 10 kΩ	Vishay Draloric	CRCW060310K0FKEAHP	FEC 1738918
R21	Resistor, power, 0805, 1%, 2.20 kΩ	Vishay Draloric	CRCW08052K20FKEAHP	FEC 1738964
R22	Resistor, 0603, 100 kΩ	Vishay Draloric	CRCW0603100KFKEA	FEC 2122619
R23	Resistor, 0603, 100 kΩ	Vishay Draloric	CRCW0603100KFKEA	FEC 2122619
R24	Resistor			DNI
R25	Resistor	Vishay Draloric		DNI
R26	Resistor	Vishay Draloric		DNI
R27	Resistor	Vishay Draloric		DNI
R28	Resistor, 0 Ω, 0603	Vishay Draloric	CRCW06030000Z0EA	FEC 1469739
R29	Resistor, 0805	Vishay Draloric	CRGH0805F39K	DNI (ADM1293) FEC 2332092 (ADM1294)
R30	Resistor, 0805, 10 kΩ (ADM1293), 39 kΩ (ADM1294)		CRGH0805F10K (ADM1293), CRGH0805F39K (ADM1294)	FEC 2332084 (ADM1293) FEC 2332092 (ADM1294)
R31	Resistor, 0805	Vishay Draloric	CRGH0805F39K	DNI (ADM1293) FEC 2332092 (ADM1294)
R32	Resistor, 0805	N/A	CRGH0805F39K	DNI (ADM1293) FEC 2332092 (ADM1294)
R33	Resistor	Vishay Draloric		DNI
R34	Resistor, 0 Ω, 0603		CRCW06030000Z0EA	FEC 1469739
R35	Resistor, 0 Ω, 0603		CRCW06030000Z0EA	FEC 1469739 (ADM1293) DNI (ADM1294)
R36	Resistor	Vishay Draloric		DNI
R37	Resistor, 06030.1 W, 10 Ω		CRCW060310R0FKEA	FEC 1469751
RD1	Resistor			DNI
RD2	Resistor, 0 Ω, 0603		CRCW06030000Z0EA	FEC 1469739
RD3	Resistor			DNI
RD4	Resistor, 0 Ω, 0603		CRCW06030000Z0EA	FEC 1469739
RP	Trimmer pot, 100 kΩ	Vishay Spectrol	M63M104KB30T607	FEC 9608265
RS1	Resistor, power, 1206, 1%, 21.0 kΩ		RP73D2B21KBTG	DNI (ADM1293) FEC 1501743 (ADM1294)
RS2	Resistor, power, 1206, 1%, 21.0 kΩ		RP73D2B21KBTG	DNI (ADM1293) FEC 1501743 (ADM1294)
RS3	Resistor, power, 1206, 1%, 21.0 kΩ		RP73D2B21KBTG	DNI (ADM1293) FEC 1501743 (ADM1294)
RSENSE1	Sense resistor (2512 case size), 0.0005 Ω (ADM1293), 0.002 Ω (ADM1294)		ULR3-R0005FT2 (ADM1293), ULR2-R002FT2 (ADM1294)	FEC 1292504 (ADM1293) FEC 1292491RL (ADM1294)
RSENSE2	Resistor, 0805, 100 Ω (ADM1293), 39 Ω (ADM1294)		CRGH0805F100R (ADM1293), CRCW080539R0FKEAHP (ADM1294)	FEC 2332058 (ADM1293) FEC 1738941RL (ADM1294)
RSENSE3	Resistor			DNI
RVCC	Resistor, 0603, 10 Ω	Vishay Draloric	CRCW060310R0FKEA	FEC 1469751 (ADM1293) DNI (ADM1294)
RVIN	Resistor, 0 Ω, 0603		CRCW06030000Z0EA	FEC 1469739 (ADM1293) DNI (ADM1294)
RVIN1	Resistor, 0805, 1 kΩ, 0.33 W, 1%	Vishay Draloric	CRCW08051K00FKEAHP	DNI (ADM1293) FEC 1738959 (ADM1294)

Reference Designator	Description	Manufacturer	Part Number	Stock Code
RVIN2	Resistor, 0603, 47 kΩ	Vishay Draloric	CRCW060347K0FKEA	DNI (ADM1293) FEC 2122577 (ADM1294)
S2	Switch, 2.8 mm × 3.8 mm vertical push	Multicomp	MCIPTG23K-V	FEC 1605470
SK1	10-way female PTH Micromatch	TE Connectivity	8-215079-0	FEC 148600
SK2	8-way female PTH Micromatch	TE Connectivity	7-215079-8	FEC 148593
SK3	8-way female PTH Micromatch	TE Connectivity	7-215079-8	FEC 148593
SK6	Header, right angle, 1-row, 3-way	Molex		DNI
T1, T4, T5, T_3V3, T_5V, T_BGND4, T_GPO1, T_GPO2, T_IN, T_OUT, T_SN, T_SP, T_VAUX, T_VCC, T_VDD, T_VIN	Testpoint black			DNI
T_AGND1, T_AGND2	Testpoint black		202137	FEC 8731128
T_AUX	Testpoint black			DNI
T_BGND1, T_BGND2	Testpoint black		202137	FEC 8731128
T_BGND3	Testpoint black		202137	DNI
U1	ADM1293/ADM1294 digital power monitor with PMBus interface		ADM1293-1AACPZ, ADM1294-1AACPZ	ADM1293-1AACPZ ADM1294-1AACPZ
U2	IC EEPROM serial 64 KB SMD MSOP8	Microchip	24LC64-I/MS	FEC 1331335
VDD	Terminal screw VERT SNAP-IN PC MNT	Keystone	7691	Digi-Key 7691K-ND

I²C refers to a communications protocol originally developed by Philips Semiconductor (now NXP Semiconductors).



ESD Caution

ESD (electrostatic discharge) sensitive device. Charged devices and circuit boards can discharge without detection. Although this product features patented or proprietary protection circuitry, damage may occur on devices subjected to high energy ESD. Therefore, proper ESD precautions should be taken to avoid performance degradation or loss of functionality.

Legal Terms and Conditions

By using the evaluation board discussed herein (together with any tools, components documentation or support materials, the "Evaluation Board"), you are agreeing to be bound by the terms and conditions set forth below ("Agreement") unless you have purchased the Evaluation Board, in which case the Analog Devices Standard Terms and Conditions of Sale shall govern. Do not use the Evaluation Board until you have read and agreed to the Agreement. Your use of the Evaluation Board shall signify your acceptance of the Agreement. This Agreement is made by and between you ("Customer") and Analog Devices, Inc. ("ADI"), with its principal place of business at One Technology Way, Norwood, MA 02062, USA. Subject to the terms and conditions of the Agreement, ADI hereby grants to Customer a free, limited, personal, temporary, non-exclusive, non-sublicensable, non-transferable license to use the Evaluation Board FOR EVALUATION PURPOSES ONLY. Customer understands and agrees that the Evaluation Board is provided for the sole and exclusive purpose referenced above, and agrees not to use the Evaluation Board for any other purpose. Furthermore, the license granted is expressly made subject to the following additional limitations: Customer shall not (i) rent, lease, display, sell, transfer, assign, sublicense, or distribute the Evaluation Board; and (ii) permit any Third Party to access the Evaluation Board. As used herein, the term "Third Party" includes any entity other than ADI, Customer, their employees, affiliates and in-house consultants. The Evaluation Board is NOT sold to Customer; all rights not expressly granted herein, including ownership of the Evaluation Board, are reserved by ADI. CONFIDENTIALITY. This Agreement and the Evaluation Board shall all be considered the confidential and proprietary information of ADI. Customer may not disclose or transfer any portion of the Evaluation Board to any other party for any reason. Upon discontinuation of use of the Evaluation Board or termination of this Agreement, Customer agrees to promptly return the Evaluation Board to ADI. ADDITIONAL RESTRICTIONS. Customer may not disassemble, decompile or reverse engineer chips on the Evaluation Board. Customer shall inform ADI of any occurred damages or any modifications or alterations it makes to the Evaluation Board, including but not limited to soldering or any other activity that affects the material content of the Evaluation Board. Modifications to the Evaluation Board must comply with applicable law, including but not limited to the RoHS Directive. TERMINATION. ADI may terminate this Agreement at any time upon giving written notice to Customer. Customer agrees to return to ADI the Evaluation Board at that time. LIMITATION OF LIABILITY. THE EVALUATION BOARD PROVIDED HEREUNDER IS PROVIDED "AS IS" AND ADI MAKES NO WARRANTIES OR REPRESENTATIONS OF ANY KIND WITH RESPECT TO IT. ADI SPECIFICALLY DISCLAIMS ANY REPRESENTATIONS, ENDORSEMENTS, GUARANTEES, OR WARRANTIES, EXPRESS OR IMPLIED, RELATED TO THE EVALUATION BOARD INCLUDING, BUT NOT LIMITED TO, THE IMPLIED WARRANTY OF MERCHANTABILITY, TITLE, FITNESS FOR A PARTICULAR PURPOSE OR NON-INFRINGEMENT OF INTELLECTUAL PROPERTY RIGHTS. IN NO EVENT WILL ADI AND ITS LICENSORS BE LIABLE FOR ANY INCIDENTAL, SPECIAL, INDIRECT, OR CONSEQUENTIAL DAMAGES RESULTING FROM CUSTOMER'S POSSESSION OR USE OF THE EVALUATION BOARD, INCLUDING BUT NOT LIMITED TO LOST PROFITS, DELAY COSTS, LABOR COSTS OR LOSS OF GOODWILL. ADI'S TOTAL LIABILITY FROM ANY AND ALL CAUSES SHALL BE LIMITED TO THE AMOUNT OF ONE HUNDRED US DOLLARS (\$100.00). EXPORT. Customer agrees that it will not directly or indirectly export the Evaluation Board to another country, and that it will comply with all applicable United States federal laws and regulations relating to exports. GOVERNING LAW. This Agreement shall be governed by and construed in accordance with the substantive laws of the Commonwealth of Massachusetts (excluding conflict of law rules). Any legal action regarding this Agreement will be heard in the state or federal courts having jurisdiction in Suffolk County, Massachusetts, and Customer hereby submits to the personal jurisdiction and venue of such courts. The United Nations Convention on Contracts for the International Sale of Goods shall not apply to this Agreement and is expressly disclaimed.