

| PART NUMBER | REV | FIRST USED |
|-------------|-----|------------|
| 680695-1    | A   | 122500-1   |
| 680695-2    | A   | 565435-5   |
| 680695-3    | A   | 354500-1   |

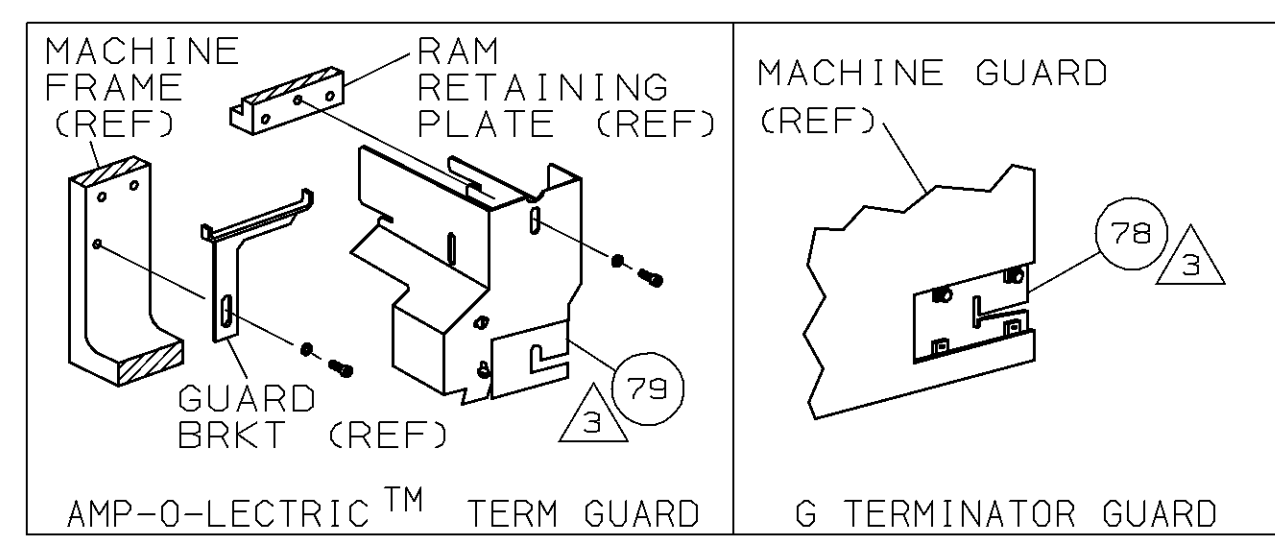
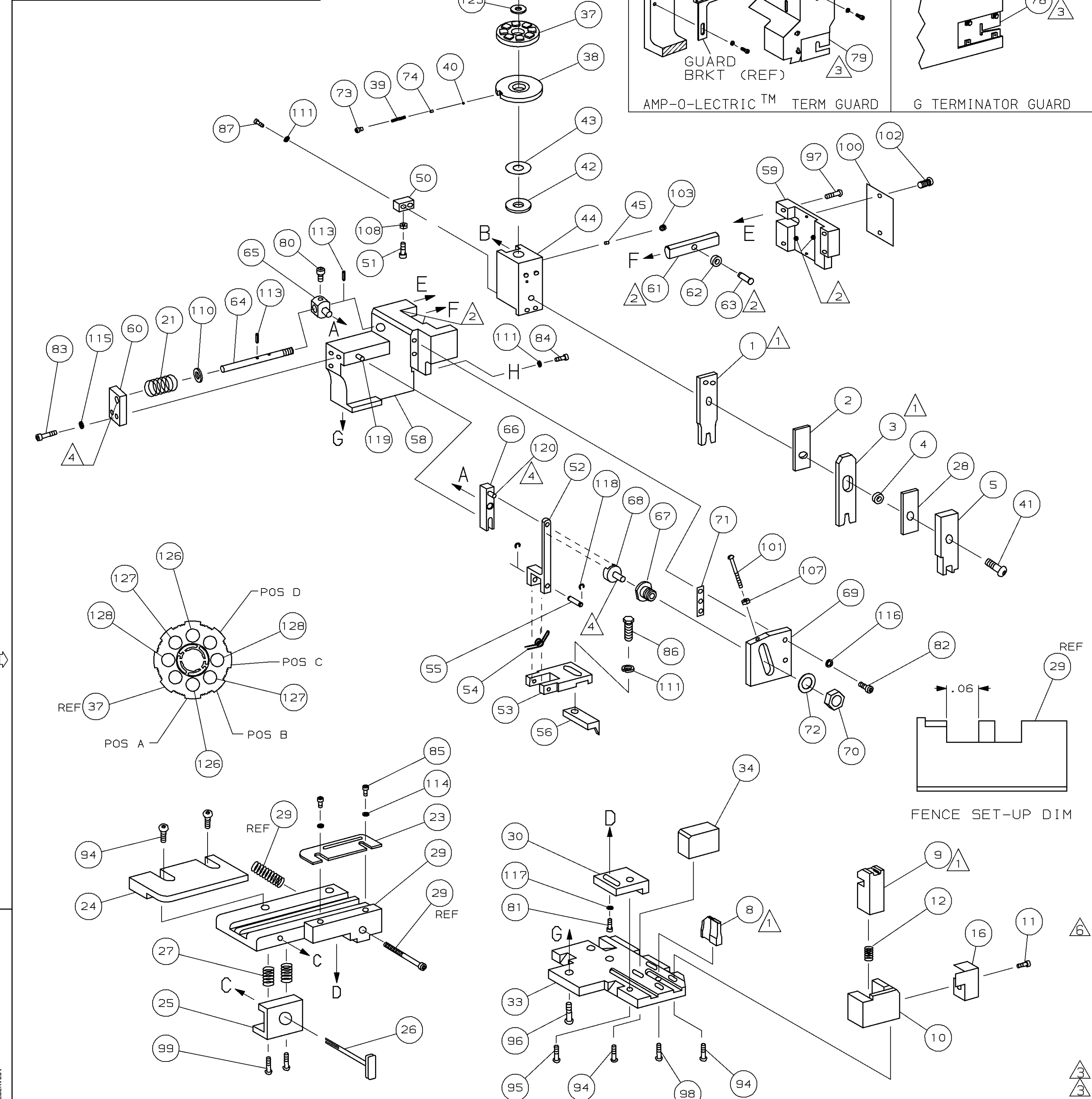

| TERMINAL NAME: Ø1MM CONTACT |                           | CRIMP DATA (AMP TERMINAL) |                                       |
|-----------------------------|---------------------------|---------------------------|---------------------------------------|
| PAD LTR                     | CRIMP HEIGHT              | WIRE SIZE                 |                                       |
| A                           | .049 ±.002 [1.26 ±0.05mm] | 1 mm <sup>2</sup>         |                                       |
| B                           | .045 ±.002 [1.15 ±0.05mm] | 0.75 mm <sup>2</sup>      |                                       |
| C                           | .041 ±.002 [1.04 ±0.05mm] | 0.5 mm <sup>2</sup>       |                                       |
| D                           | NOT                       | USED                      |                                       |
| CRIMP                       | SIZE                      | TYPE                      | RANGE                                 |
| WIRE                        | .070 [1.78mm]             | F                         | 0.5mm <sup>2</sup> - 1mm <sup>2</sup> |
| INSUL                       | .100 [2.54mm]             | OV                        | 1.4 - 2.3mm                           |

| QTY REQD PER ASSY | TERM APPL SPEC | FEED | APPL INSTRUCTION | SET UP GAGE | LAYOUT     | ITEM NO                               |         |
|-------------------|----------------|------|------------------|-------------|------------|---------------------------------------|---------|
| .156-.171         | 114-2083       | .394 | 408-8040         | 458637-1    | L2132      | 129                                   |         |
| 2                 | 2              | 2    | -                | C           | 3-354779-3 | PIN, WIRE DISC (.3155)C 128           |         |
| 2                 | 2              | 2    | -                | C           | 2-354779-4 | PIN, WIRE DISC (.3110)B 127           |         |
| 2                 | 2              | 2    | -                | C           | 1-354779-6 | PIN, WIRE DISC (.3070)A 126           |         |
| 1                 | 1              | 1    | -                | A           | 986950-1   | WASHER, FLAT PRECISION 125            |         |
| 1                 | 1              | 1    | -                | A           | 217238-1   | GENERAL INSTRUCTION PACKAGE 124       |         |
| 1                 | 1              | 1    | -                | -           | 4088040    | SF APPL INST 408-8040 123             |         |
| REF               | REF            | REF  | -                | A           | 1-21030-1  | PIN, DOWEL (Ø.187x.50) LEVER 120      |         |
| REF               | REF            | REF  | -                | A           | 1-21030-6  | PIN, DOWEL (Ø.187x1.25) HOUSING 119   |         |
| REF               | REF            | REF  | -                | A           | 21045-3    | RING, RET "C" (Ø.187) FD FING PIN 118 |         |
| 1                 | 1              | 1    | -                | A           | 21024-5    | WASHER, LOCK (#10) ADJ BLOCK 117      |         |
| REF               | REF            | REF  | -                | A           | 21024-5    | WASHER, LOCK (#10) ADJ PLATE 116      |         |
| REF               | REF            | REF  | -                | A           | 21024-5    | WASHER, LOCK (#10) FEED GDE ROD 115   |         |
| 2                 | 2              | 2    | -                | A           | 21024-2    | WASHER, LOCK (#4) FRONT STP GUIDE 114 |         |
| REF               | REF            | REF  | -                | A           | 5-21028-1  | PIN, SLT SPR (Ø.125x.50) ADJ ROD 113  |         |
| 4                 | 4              | 4    | -                | A           | 21024-4    | WASHER, LOCK (#8) STRIPPER 111        |         |
| REF               | REF            | REF  | -                | A           | 21899-4    | WASHER, FLAT (Ø5/16) SCREW ADJ 110    |         |
| 1                 | 1              | 1    | -                | A           | 21018-5    | NUT, HEX (NO. 6) HOLDDOWN 109         |         |
| REF               | REF            | REF  | -                | A           | 21068-5    | NUT, HEX (6-32) FEED ADJ 107          |         |
| 1                 | 1              | 1    | -                | A           | 992031-1   | PIN, CLEVIS 104                       |         |
| 1                 | 1              | 1    | -                | A           | 21009-2    | SCR, SKT SET (1/4-20x.25 LW) RAM 103  |         |
| 2                 | 2              | 2    | -                | A           | 21017-2    | SCR, DRIVE (#2x.19) ID PLATE 102      |         |
| REF               | REF            | REF  | -                | A           | 6-23715-5  | SCR, PAN HD (6-32x1.50) FEED ADJ 101  |         |
| 1                 | 1              | 1    | -                | B           | 461264-1   | PLATE, IDENTIFICATION 100             |         |
| 2                 | 2              | 2    | -                | A           | 3-21002-0  | SCR, BHC (10-32x.88) DRAG 99          |         |
| 1                 | 1              | 1    | -                | A           | 22733-8    | SCR, BHC (8-32x.38 LW) ANVIL 98       |         |
| REF               | REF            | REF  | -                | A           | 2-21002-9  | SCR, BHC (10-32x.75) CAP 97           |         |
| REF               | REF            | REF  | -                | A           | 2-22733-8  | SCR, BHC (1/4-20x.62) HOUSING 96      |         |
| REF               | REF            | REF  | -                | A           | 2-21002-7  | SCR, BHC (10-32x.50) SG ADJ BLOCK 95  |         |
| 6                 | 6              | 6    | -                | A           | 2-21002-2  | SCR, BHC (8-32x.50) TERM H DWN 94     |         |
| 1                 | 1              | 1    | -                | A           | 1-21002-7  | SCR, BHC (6-32x.38) CAM 91            |         |
| 1                 | 1              | 1    | -                | A           | 7-21000-9  | SCR, SHC (4-40x.19) STRIPPER 89       |         |
| 2                 | 2              | 2    | -                | A           | 2-21000-7  | SCR, SHC (8-32x.48) DEP-HOLD 87       |         |
| 1                 | 1              | 1    | -                | A           | 2-22603-0  | SCR, HEX HD (8-32x.31) FEED FINGER 86 |         |
| 2                 | 2              | 2    | -                | A           | 1-21000-3  | SCR, SHC (4-40x.25) F ST GUIDE 85     |         |
| 1                 | 1              | 1    | -                | A           | 2-21000-7  | SCR, SHC (8-32x.50) STRIPPER 84       |         |
| REF               | REF            | REF  | -                | A           | 3-21000-7  | SCR, SHC (10-32x.75) FEED ROD GD 83   |         |
| REF               | REF            | REF  | -                | A           | 3-21000-6  | SCR, SHC (10-32x.62) FD ADJ BLK 82    |         |
| 1                 | 1              | 1    | -                | A           | 3-21000-4  | SCR, SHC (10-32x.38) SG ADJ BL 81     |         |
| REF               | REF            | REF  | -                | A           | 3-21000-4  | SCR, SHC (10-32x.38) PIVOT BLK 80     |         |
| -                 | REF            | -    | -                | B           | 455749-1   | GUARD, WINDOW 79                      |         |
| REF               | -              | -    | -                | B           | 679532-1   | INSERT, GUARD 78                      |         |
| 1                 | 1              | 1    | -                | A           | 690603-1   | SPRING, ASSIST 74                     |         |
| 1                 | 1              | 1    | -                | A           | 23030-1    | SCR, SHC (6-32x.25 SL) INS DISC 73    |         |
| REF               | REF            | REF  | -                | A           | 458109-1   | WASHER, SPECIAL 72                    |         |
| REF               | REF            | REF  | -                | A           | 690517-1   | SPACER 71                             |         |
| -3                | -2             | -1   | U/M              | DWG SIZE    | PART NO    | DESCRIPTION                           | ITEM NO |

| QTY REQD PER ASSY | LEADMAKER     | MECH POST FEED | MECH PRE FEED | MECH PRE FEED | ITEM NO    |                                |         |
|-------------------|---------------|----------------|---------------|---------------|------------|--------------------------------|---------|
| -1                | REF           | REF            | -             | B             | 22594-8    | NUT, HEX (1/2-20) 70           |         |
| -2                | BENCH MODEL K | MECH POST FEED |               |               | 240628-1   | PLATE, ADJUSTMENT 69           |         |
| -3                | BENCH MODEL G | MECH PRE FEED  |               |               | 240626-1   | SHAFT, PIVOT 68                |         |
| REF               | REF           | REF            | -             | B             | 240633-1   | BUSHING 67                     |         |
| REF               | REF           | REF            | -             | A             | 455680-1   | LEVER, INTERMEDIATE 66         |         |
| REF               | REF           | REF            | -             | B             | 240629-1   | BLOCK, PIVOT 65                |         |
| REF               | REF           | REF            | -             | A             | 240632-2   | SCREW, ADJ FEED ROD 64         |         |
| REF               | REF           | REF            | -             | B             | 240659-3   | PIN, CAM ROLLER 63             |         |
| REF               | REF           | REF            | -             | B             | 240658-1   | ROLLER, CAM 62                 |         |
| REF               | REF           | REF            | -             | B             | 454398-2   | ROD, FEED 61                   |         |
| REF               | REF           | REF            | -             | A             | 454178-1   | GUIDE, FEED ROD 60             |         |
| REF               | REF           | REF            | -             | C             | 454220-1   | CAP, RAM 59                    |         |
| REF               | REF           | REF            | -             | D             | 454485-1   | HOUSING 58                     |         |
| 1                 | 1             | 1              | -             | B             | 690542-2   | PAWL, FEED 56                  |         |
| REF               | REF           | REF            | -             | B             | 240624-1   | PIN, FEED FINGER 55            |         |
| REF               | REF           | REF            | -             | B             | 691499-1   | SPRING, FEED FINGER 54         |         |
| REF               | REF           | REF            | -             | B             | 690541-1   | HOLDER, FEED FINGER 53         |         |
| REF               | REF           | REF            | -             | A             | 455679-1   | LEVER, TERMINAL FEED ARM 52    |         |
| 1                 | 1             | 1              | -             | A             | 811242-2   | BUMPER, HOLDDOWN 51            |         |
| 1                 | 1             | 1              | -             | A             | 690753-1   | SPACER, TONKER 50              |         |
| 1                 | -             | -              | -             | B             | 690602-6   | CAM, PRE-FEED 1 5/8 ST 49      |         |
| -                 | 1             | -              | -             | B             | 690602-5   | CAM, PRE-FEED 1 1/8 ST 48      |         |
| -                 | -             | -              | -             | B             | 690501-4   | CAM, POST-FEED 1 5/8 ST 47     |         |
| 1                 | 1             | 1              | -             | B             | 459456-1   | APPLICATOR, BASIC (SUBASSY) 46 |         |
| 1                 | 1             | 1              | -             | A             | 690191-1   | PLUG, NYLON 45                 |         |
| 1                 | 1             | 1              | -             | C             | 455673-1   | RAM 44                         |         |
| 1                 | 1             | 1              | -             | A             | 690125-1   | WASHER, LAMINATED 43           |         |
| 1                 | 1             | 1              | -             | A             | 690124-1   | WASHER, RAM 42                 |         |
| 1                 | 1             | 1              | -             | A             | 7-21002-9  | BOLT, CRIMPER (5/16x1.00) 41   |         |
| 1                 | 1             | 1              | -             | A             | 23241-6    | BALL, STEEL 40                 |         |
| 1                 | 1             | 1              | -             | A             | 690170-1   | SPRING, COMPRESSION 39         |         |
| 1                 | 1             | 1              | -             | C             | 690142-1   | DISC, INSULATION 38            |         |
| 1                 | 1             | 1              | -             | D             | 354777-1   | WIRE DISC, PLASTIC 37          |         |
| 1                 | 1             | 1              | -             | A             | 22480-5    | WASHER, SPRING 36              |         |
| 1                 | 1             | 1              | -             | B             | 690212-1   | POST, RAM 35                   |         |
| 1                 | 1             | 1              | -             | B             | 2-690786-3 | SUPPORT, TERMINAL 34           |         |
| REF               | REF           | REF            | -             | D             | 455675-1   | PLATE, BASE 33                 |         |
| 1                 | 1             | 1              | -             | B             | 455689-1   | BLOCK, STRIP GUIDE ADJ 30      |         |
| 1                 | 1             | 1              | -             | C             | 318756-1   | STRIP GUIDE PLATE ASSY 29      |         |
| 1                 | 1             | 1              | -             | C             | 1-455888-5 | SPACER, FRONT SHEAR DEP 28     |         |
| 2                 | 2             | 2              | -             | A             | 1-22284-0  | SPRING, DRAG 27                |         |
| 1                 | 1             | 1              | -             | B             | 690546-1   | LEVER, DRAG RELEASE 26         |         |
| 1                 | 1             | 1              | -             | B             | 240792-1   | DRAG, TERMINAL 25              |         |
| 1                 | 1             | 1              | -             | D             | 6-690504-3 | GUIDE, STRIP (REAR) 24         |         |
| 1                 | 1             | 1              | -             | A             | 690438-1   | GUIDE, STRIP (FRONT) 23        |         |
| -                 | -             | 1              | -             | B             | 690472-2   | STRIPPER 22                    |         |
| REF               | REF           | REF            | -             | A             | 4-22284-9  | SPRING, FEED RETURN 21         |         |
| 1                 | 1             | 1              | -             | A             | 679218-1   | STRIPPER WIRE STOP ASSY 20     |         |
| 1                 | 1             | 1              | -             | B             | 458949-1   | STRIPPER 19                    |         |
| 1                 | 1             | 1              | -             | B             | 318563-1   | GUARD, CHIP, FRONT 16          |         |
| 1                 | 1             | 1              | -             | A             | 5-22280-0  | SPRING, SHEAR 12               |         |
| 1                 | 1             | 1              | -             | B             | 690461-1   | STOP, SHEAR 11                 |         |
| 1                 | 1             | 1              | -             | C             | 690459-1   | HOLDER, SHEAR (FRONT) 10       |         |
| 1                 | 1             | 1              | -             | C             | 454276-1   | SHEAR, FLOAT (FRONT) 9         |         |
| 1                 | 1             | 1              | -             | C             | 1-662185-8 | ANVIL 8                        |         |
| 1                 | 1             | 1              | -             | C             | 1-455889-4 | DEPRESSOR, SHEAR (FRONT) 5     |         |
| 1                 | 1             | 1              | -             | B             | 238011-5   | SPACER, BLOCK CRIMPER 4        |         |
| 1                 | 1             | 1              | -             | C             | 2-854830-4 | CRIMPER, INSULATION 3          |         |
| 1                 | 1             | 1              | -             | C             | 455888-4   | SPACER, CRIMPER 2              |         |
| 1                 | 1             | 1              | -             | C             | 1-456404-8 | CRIMPER, WIRE 1                |         |
| -3                | -2            | -1             | U/M           | DWG SIZE      | PART NO    | DESCRIPTION                    | ITEM NO |

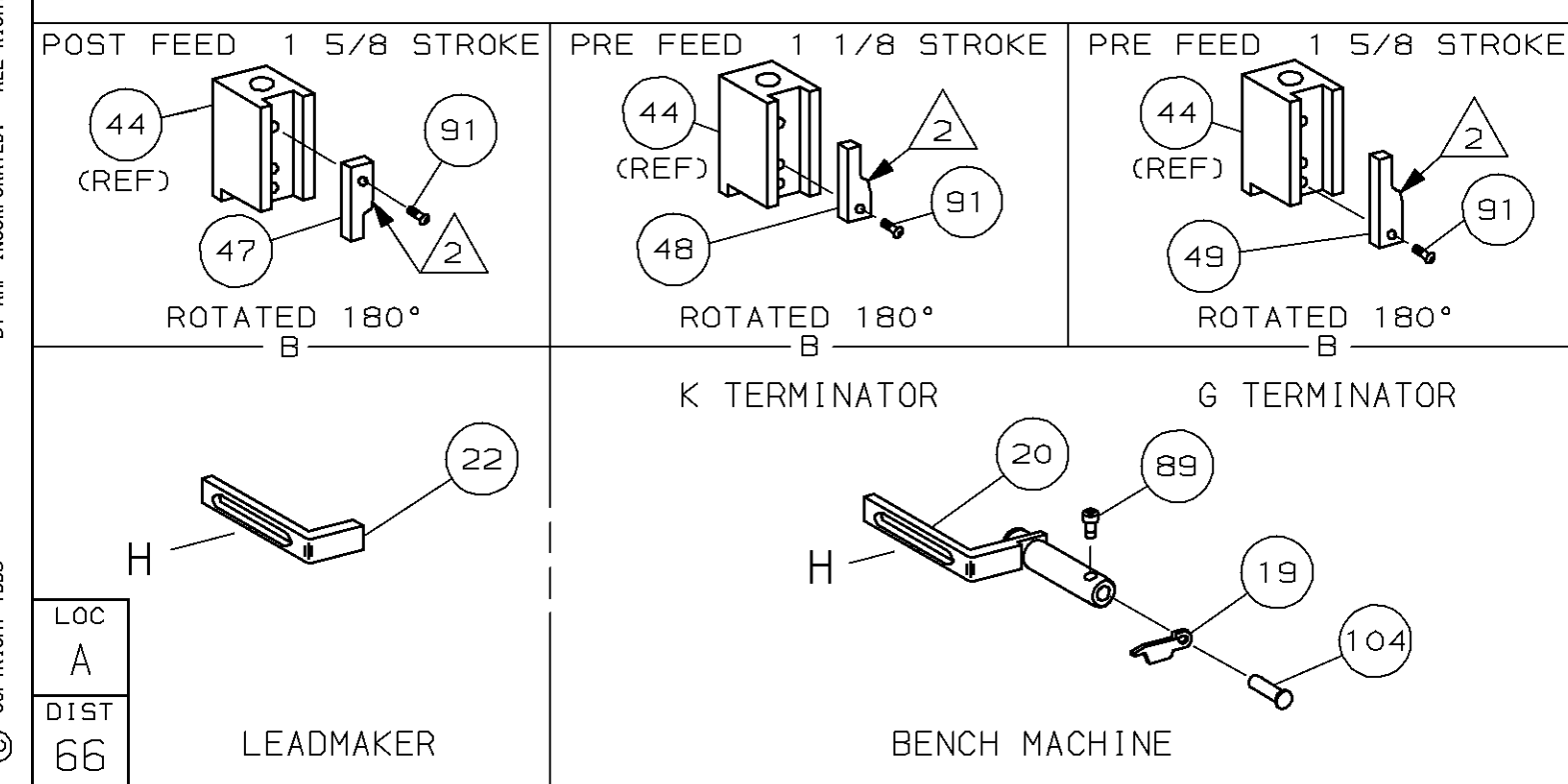

- 1 RECOMMENDED SPARE PARTS.
- 2 GREASE LIGHTLY.
- 3 GUARD MUST BE IN PLACE WHEN OPERATING APPLICATOR IN A BENCH MACHINE.
- 4 LUBRICATE DAILY USING NO. 20 MACHINE OIL.
- 5. ITEMS WITH QTY OF REF SPECIFIED (EXCEPT ITEMS 78 AND 79) ARE USED ON ITEM 46.
- 6 CUT TO LENGTH AT ASSY