

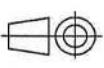

CRIMP DATA (TE TERMINAL)					
TERMINAL NAME	SOCKET CONTACT 180 DEG, 25 SQMM, WIRE CRIMP				
CRIMP	SIZE	TYPE		RANGE	
WIRE	COROPLAST				25 mm ²
INSUL					
WIRE STRIP LENGHT	20 +/- 1		APPLICATOR INSTRUCTION		
TERMINAL APPL SPEC 114-94125	PRODUCT SPECIFICATION			FEED	
TERMINALS APPLIED			SEALS		
2177473-1	-	-	-	-	-
-	-	-	-	-	-
-	-	-	-	-	-
-	-	-	-	-	-
-	-	-	-	-	-
-	-	-	-	-	-
WIRE SIZE (mm ² AWG)		CRIMP HEIGHT		REF SETTING	
25		7,6 +/- 0,1			
-		-		-	
-		-		-	
-		-		-	
-		-		-	
-		-		-	
-		-		-	
-		-		-	
REMARK: Applicator only used in combination with Coroplast (LV216-2)					
TYPE: Applicator for loose piece terminals					
TERMINATOR: HV CRIMPING MACHINE 528008-4					

P	LTR	REVISION RECORD	DATE	DWN	APVD	PRINTED	DWN	04SEP12	CHK	APVD
-	D1	SEE SHEET 1	-	-	-	26SEP16	C.WITT	-	-	-
-	E	SEE SHEET 1	-	-	-	WEIGHT	DIMENSION (mm)	MATERIAL	HT TR	-
-	E1	SEE SHEET 1	-	-	-	-	-	-	-	-
-	F	SEE SHEET 4	26SEP16	CW	GS	 TOLERANCES UNLESS OTHERWISE SPECIFIED SEE SHEET 1		 tyco Electronics AMP GmbH D-64625 Bensheim SPARE AND WEAR PARTS LIST		
THIS DRAWING IS A CONTROLLED DOCUMENT FOR TYCO ELECTRONICS CORPORATION. IT IS SUBJECT TO CHANGE AND THE CONTROLLING ENGINEERING ORGANIZATION SHOULD BE CONTACTED FOR THE LATEST REVISION. DIESES ZEICHNUNGSDOKUMENT WIRD DURCH TYCO ELECTRONICS CORPORATION KONTROLLIERT. ÄNDERUNGEN DIE DEM TECHNISCHEM FORTSCHRITT DIENEN, SIND VORBEHALTEN. DEN JEWEILS LETZTGÜLTIGEN ÄNDERUNGSSTAND ERFAHREN SIE AUF ANFRAGE						NAME APPLICATOR HV, 180AK, CAT2, 25SQ.MM				RESTRICTED TO
SCALE		SIZE		DRAWING NO		SHEET		REV		
SEE SHEET 1		A4		C-541872-2		1 / 4		F		

POS	QTY	TE/PN	DESCRIPTION	S=Spear Parts W=Wear Parts	S	W
1	1	7-0519714-7	BASE PLATE GRUNDPLATTE		<input checked="" type="checkbox"/>	<input type="checkbox"/>
2	1	0-0519720-1	TOP PLATE KOPFPLATTE		<input checked="" type="checkbox"/>	<input type="checkbox"/>
3	1	2-0519715-6	HOLDER HALTER		<input checked="" type="checkbox"/>	<input type="checkbox"/>
4	1	5-0519709-2	CRIMPER LOCATOR CRIMPERAUFNAHME		<input checked="" type="checkbox"/>	<input type="checkbox"/>
8	1	7-1579019-5	DIE SET HV, 180-AK, 25SQ.MM		<input checked="" type="checkbox"/>	<input checked="" type="checkbox"/>
13	1	7-0519714-8	PLATE PLATTE		<input checked="" type="checkbox"/>	<input type="checkbox"/>
15	1	2-0519715-7	HOLDER HALTER		<input checked="" type="checkbox"/>	<input type="checkbox"/>
17	1	2-0519715-8	HOLDER HALTER		<input checked="" type="checkbox"/>	<input type="checkbox"/>
18	1	8-0519714-0	PLATE PLATTE		<input checked="" type="checkbox"/>	<input checked="" type="checkbox"/>
19	1	5-0519564-3	HOUSING GEHÄUSE		<input checked="" type="checkbox"/>	<input type="checkbox"/>
20	1	8-0519714-1	PLATE PLATTE		<input checked="" type="checkbox"/>	<input type="checkbox"/>
21	1	8-0519714-2	STOP PLATE ANSCHLAGPLATTE		<input checked="" type="checkbox"/>	<input checked="" type="checkbox"/>
23	1	6-0519514-1	RAM STÖSSEL		<input checked="" type="checkbox"/>	<input type="checkbox"/>
24	1	2-0519703-8	PIN STIFT		<input checked="" type="checkbox"/>	<input type="checkbox"/>
25	2	0-2079970-1	GUIDE BUSHING, BALL FÜHRUNGSBUCHSE		<input checked="" type="checkbox"/>	<input type="checkbox"/>
26	2	0-2079969-1	GUIDE PILLAR, SHOULDER FUEHRUNGSSAEULE MIT SCHULT		<input checked="" type="checkbox"/>	<input type="checkbox"/>
31	2	9-0519051-1	ZYL.-STIFT 6M6*30 DIN 6325 -ST		<input checked="" type="checkbox"/>	<input type="checkbox"/>
32	4	3-0519000-2	SCREW, CAP, SOCKET HD, METRIC		<input checked="" type="checkbox"/>	<input type="checkbox"/>
33	1	5-0519585-3	TONGUE LASCHE		<input checked="" type="checkbox"/>	<input type="checkbox"/>
34	1	0-2079833-1	HANDLE, BOW, OVAL		<input checked="" type="checkbox"/>	<input type="checkbox"/>
35	1	6-0519000-8	SCREW, CAP, SOCKET HD, METRIC		<input checked="" type="checkbox"/>	<input type="checkbox"/>
39	2	3-0519000-7	SCREW, CAP, SOCKET HD, METRIC		<input checked="" type="checkbox"/>	<input type="checkbox"/>
40	1	4-0519000-1	SCREW, CAP, SOCKET HD, METRIC		<input checked="" type="checkbox"/>	<input type="checkbox"/>
41	2	4-0519000-2	SCREW, CAP, SOCKET HD, METRIC		<input checked="" type="checkbox"/>	<input type="checkbox"/>

REMARKS: APPLICATOR HV-180AK CAT2 NUR ZUR VERARBEITUNG VON 25 QMM

USED ON

P	LTR	REVISION RECORD	DATE	DWN	APVD	PRINTED	DWN	04SEP12	CHK	APVD
-	D1	SEE SHEET 1	-	-	-	26SEP16	C.WITT	-	-	-
-	E	SEE SHEET 1	-	-	-	WEIGHT	DIMENSION (mm)	MATERIAL	HT TR	-
-	E1	SEE SHEET 1	-	-	-					
-	F	SEE SHEET 4	-	-	-					

THIS DRAWING IS A CONTROLLED DOCUMENT FOR TYCO ELECTRONICS CORPORATION. IT IS SUBJECT TO CHANGE AND THE CONTROLLING ENGINEERING ORGANIZATION SHOULD BE CONTACTED FOR THE LATEST REVISION.

DIESES ZEICHNUNGSDOKUMENT WIRD DURCH TYCO ELECTRONICS CORPORATION KONTROLLIERT. ÄNDERUNGEN DIE DEM TECHNISCHEN FORTSCHRITT DIENEN, SIND VORBEHALTEN. DEN JEWEILS LETZTGÜLTIGEN ÄNDERUNGSSTAND ERFAHREN SIE AUF ANFRAGE



TOLERANCES UNLESS OTHERWISE SPECIFIED SEE SHEET 1



tyco Electronics AMP GmbH
D-64625 Bensheim

SPARE AND WEAR PARTS LIST

NAME APPLICATOR HV, 180AK, CAT2, 25SQ.MM				RESTRICTED TO	
SCALE SEE SHEET 1	SIZE A4	DRAWING NO C-541872-2	SHEET 2 / 4	REV F	

THIS DRAWING IS UNPUBLISHED. RELEASED FOR PUBLICATION 2012
 © COPYRIGHT 2012 Tyco Electronics AMP GmbH ALL RIGHTS RESERVED.

LOC	DIST	REVISIONS			
P	LYR	DESCRIPTION	DATE	DRW	APPV
F		ECR-16-012972	22SEP2016	CW	GS

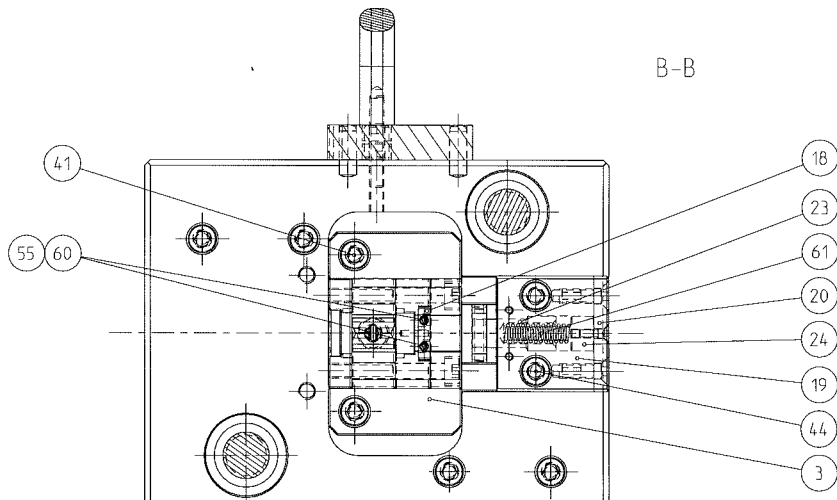
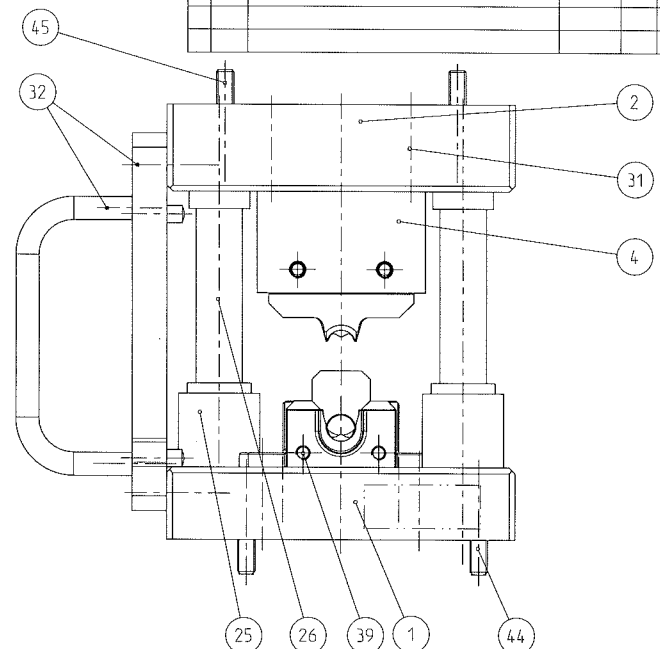
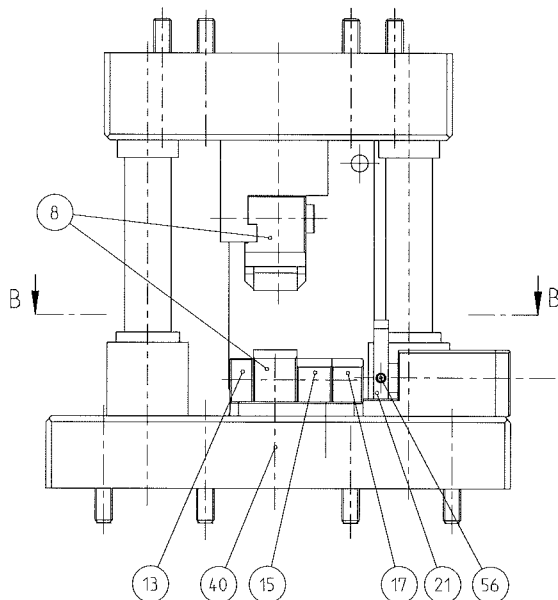
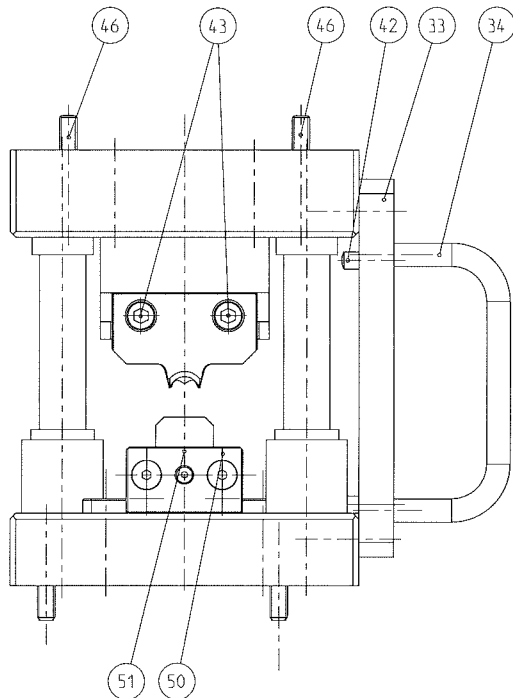

Application range / Anwendungsbereich

For HV 8mm socket contact 180 deg, 25sqmm P/N 2177473-1.
 Fuer HV 8mm Buchsenkontakt 180°, 25qmm P/N 2177473-1.

In combination with HV Crimp machine P/N 526008-4.
 Einsatz in HV Crimpmaschine P/N 526008-4.

THIS DRAWING IS A CONTROLLED DOCUMENT.		DWN R. Germann 29MAY2012	 TE Connectivity										
DIMENSIONS: mm		CHR G. Stegmayer 29MAY2012											
TOLERANCES UNLESS OTHERWISE SPECIFIED:		APVD G. Stegmayer 29MAY2012	NAME										
<table border="1"> <tr><td>0 PLC</td><td>±0.1</td></tr> <tr><td>1 PLC</td><td>±0.1</td></tr> <tr><td>2 PLC</td><td>±0.1</td></tr> <tr><td>3 PLC</td><td>±0.1</td></tr> <tr><td>4 PLC</td><td>±0.1</td></tr> </table>		0 PLC	±0.1	1 PLC	±0.1	2 PLC	±0.1	3 PLC	±0.1	4 PLC	±0.1	PRODUCT SPEC	APPLICATOR HV, 180AK, CAT2, 25SQ.MM
0 PLC	±0.1												
1 PLC	±0.1												
2 PLC	±0.1												
3 PLC	±0.1												
4 PLC	±0.1												
MATERIAL		APPLICATION SPEC	SIZE CAGE CODE DRAWING NO										
FINISH		WEIGHT	RESTRICTED TO										
		CUSTOMER DRAWING	A200779 ©=541872-2										
		SCALE 1:1	SHEET 4 of 4 REV F										