

930560090

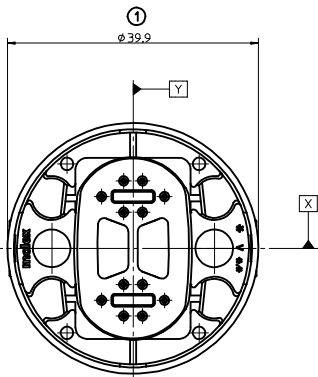

930560001

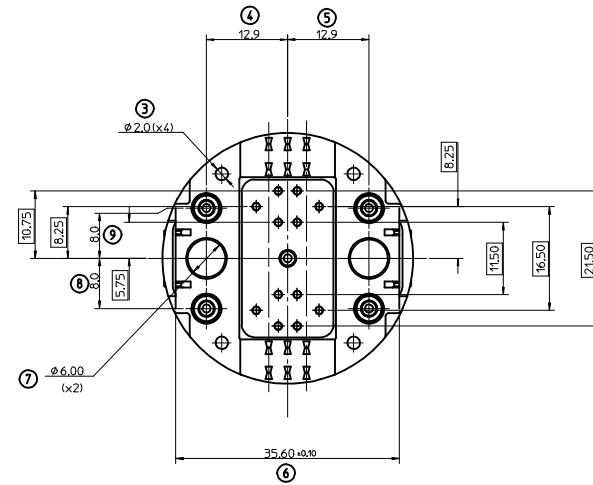
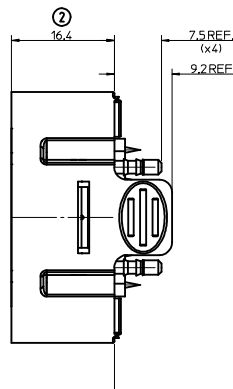

930560001

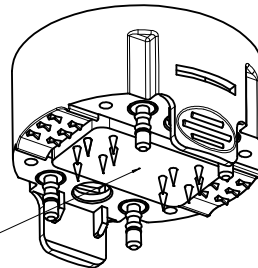
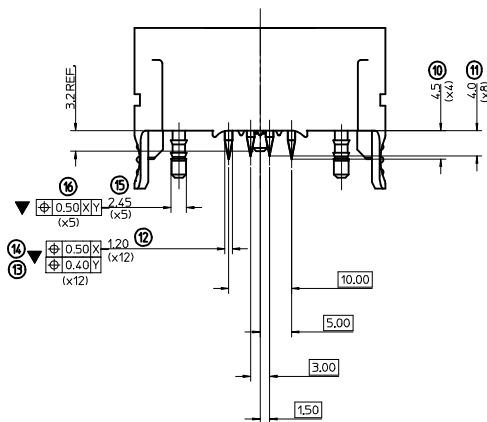
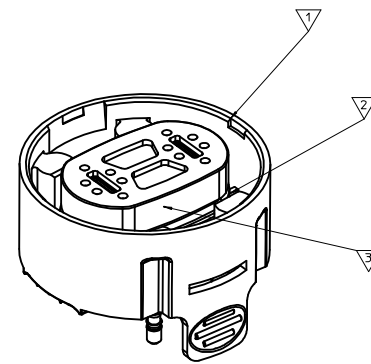
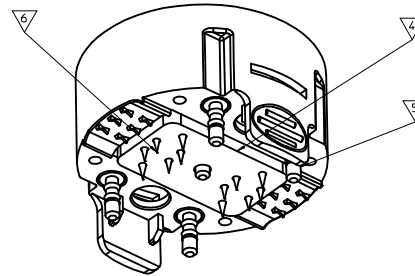

NOTE 4

930560090

COMPONENT	DESCRIPTION
1	CABLE CONNECTOR TOP
2	CABLE CONNECTOR SEAL
3	CABLE CONNECTOR SLEEVE
4	CABLE CONNECTOR TOP GEL MAT
5	CABLE CONNECTOR STUD
6	CABLE CONNECTOR PIN

NOTES

- SEE CHART FOR MATERIAL AND PLATING INFORMATION
- PACKAGING: SEE PK-93056-001
- SEE PRODUCT SPEC PS-93056-001
- AS 930560001 WITHOUT THE CENTER STUD LOADED
- POLARIZING FEATURE

LAST INSPECTION NUMBER 35

PART NUMBER	DESCRIPTION
930560001	CABLE CONNECTOR MODULE
930560090	CABLE CONNECTOR MODULE, NO CENTER STUD, POLARIZED

ADDED OPTION EC NO: IPG2015-185Z DRW:DMAHER 2015/04/23 CHKD: APPR:STR/IFF:IN 2015/08/19	QUALITY SYMBOLS ▽=2 ▽=0	GENERAL TOLERANCES (UNLESS SPECIFIED) mm INCH 4 PLACES ± --- ± --- 3 PLACES ± --- ± --- 2 PLACES ± 0.15 ± --- 1 PLACE ± 0.3 ± --- ANGULAR ± 2°	DIMENSION STYLE MM ONLY	SCALE 2.5:1	DESIGN UNITS METRIC	THIRD ANGLE PROJECTION
	DRAWN BY DMAHER	DATE 7/11/2007	CHECKED BY MSHANAHAN	DATE 7/11/2007	APPROVED BY EFOLAN	DATE 7/11/2007
DRAFT WHERE APPLICABLE MUST REMAIN WITHIN DIMENSIONS		SEE TABLE		MOLEX INCORPORATED		SHEET NO. 1 OF 3

COMPONENT	DESCRIPTION
1	CABLE CONNECTOR BASE PBT 30% GF, COLOUR BLACK
2	CABLE CONNECTOR BASE GEL MAT SUSPENDED LIQUID SILICONE, COLOUR BLUE

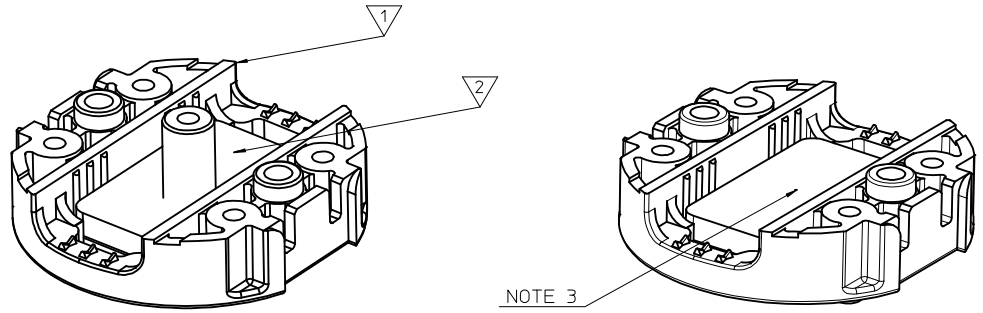

930560051

930560055

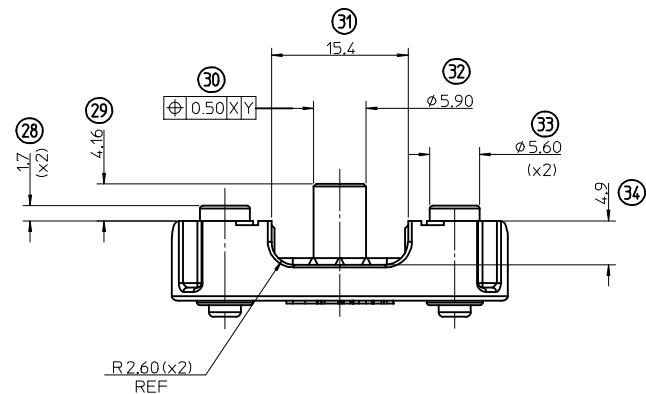
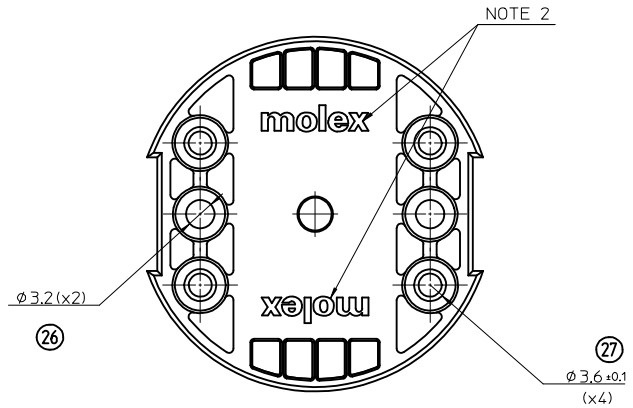
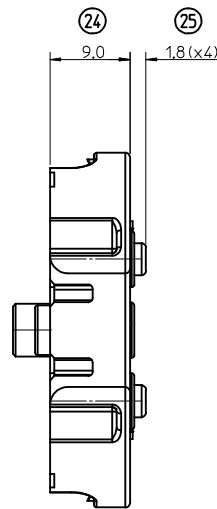
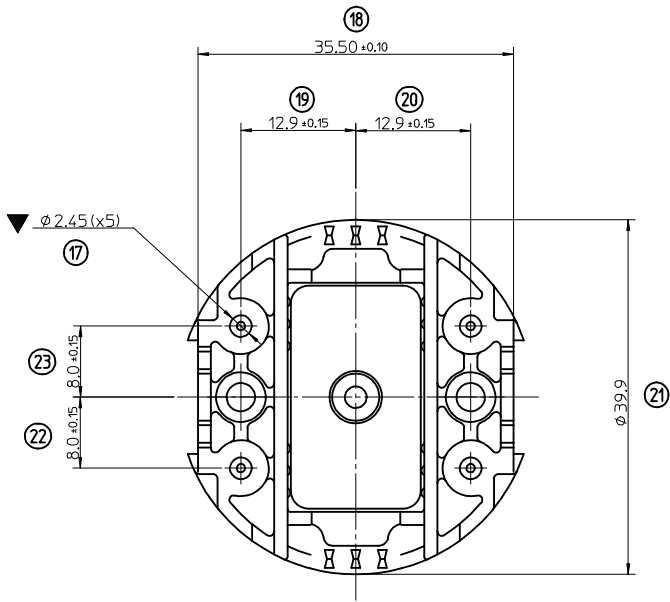

NOTES

- SEE CHART FOR MATERIAL INFORMATION
- LOGO EMBOSSED 0.3 MM TYP
- AS 930560051 WITHOUT CENTRE POST

PART NUMBER	DESCRIPTION
930560051	CABLE CONNECTOR BASE WITH POST
930560055	CABLE CONNECTOR BASE WITHOUT POST

REV	DESCRIPTION	QUALITY SYMBOLS	GENERAL TOLERANCES (UNLESS SPECIFIED)		DIMENSION STYLE		SCALE	DESIGN UNITS	THIRD ANGLE PROJECTION
			mm	INCH	MM ONLY	2.5:1	METRIC	THIRD ANGLE PROJECTION	
ADDED OPTION	EC NO: IFC2015-185Z	▽=1	4 PLACES ± ---	± ---	DRAWN BY	DATE	TITLE	CABLE CONNECTOR MODULE	
D	DRWN:DMAHER 2015/04/23	▽=0	3 PLACES ± ---	± ---	DMAHER	7/11/2007			
	CHKD: APPR:STGRUFFIN 2015/08/19		2 PLACES ± 0.15	± ---	CHECKED BY	DATE			
			1 PLACE ± 0.3	± ---	MSHANAHAN	7/11/2007			
			ANGULAR ± 2 °		APPROVED BY	DATE			
			DRAFT WHERE APPLICABLE MUST REMAIN WITHIN DIMENSIONS		EFOLAN	7/11/2007			
					MATERIAL NO.		DOCUMENT NO.		SHEET NO.
					SEE TABLE		SD-93056-001		2 OF 3
					THIS DRAWING CONTAINS INFORMATION THAT IS PROPRIETARY TO MOLEX INCORPORATED AND SHOULD NOT BE USED WITHOUT WRITTEN PERMISSION				

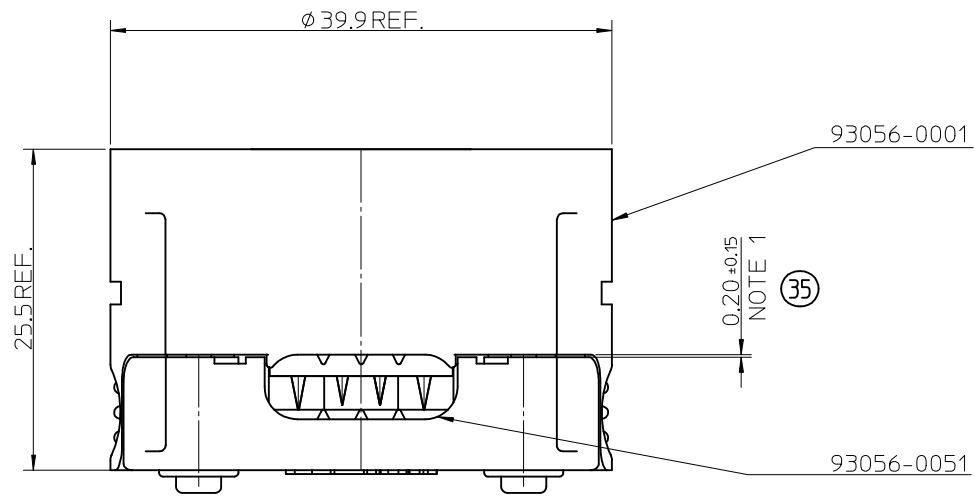

MATING OF 93056-0001 WITH 93056-0051
OR 93056-0090 WITH 93056-0055

NOTE

1: DIMENSION TO ENSURE CORRECT MATING DISTANCE FOR CONNECTORS

SEE SHEET 1 EC NO: IPG2015-1852 DRW:DMAHER 2015/04/23 CHKD: APPR:STGRIFFIN 2015/08/19	DESCRIPTION REV	QUALITY SYMBOLS	GENERAL TOLERANCES (UNLESS SPECIFIED)		DIMENSION STYLE MM ONLY		SCALE 5:1	DESIGN UNITS METRIC	THIRD ANGLE PROJECTION	
		$\nabla = 0$ $\square = 0$	mm	INCH	DRAWN BY DMAHER	DATE 7/11/2007	TITLE CABLE CONNECTOR MODULE			
		4 PLACES	± ---	± ---	CHECKED BY MSHANAHAN	DATE 7/11/2007				
			3 PLACES	± ---	± ---	APPROVED BY EFOLAN	DATE 7/11/2007	MATERIAL NO. 930560100		DOCUMENT NO. SD-93056-001
	2 PLACES	± 0.15	± ---	ANGULAR ± 2 °		SHEET NO. 3 OF 3				
	1 PLACE	± 0.3	± ---	DRAFT WHERE APPLICABLE MUST REMAIN WITHIN DIMENSIONS		THIS DRAWING CONTAINS INFORMATION THAT IS PROPRIETARY TO MOLEX INCORPORATED AND SHOULD NOT BE USED WITHOUT WRITTEN PERMISSION				

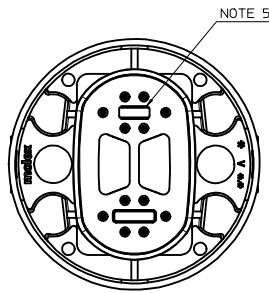

930560090

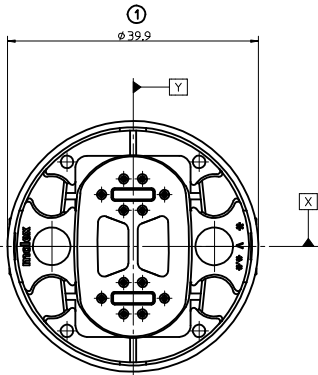

930560001

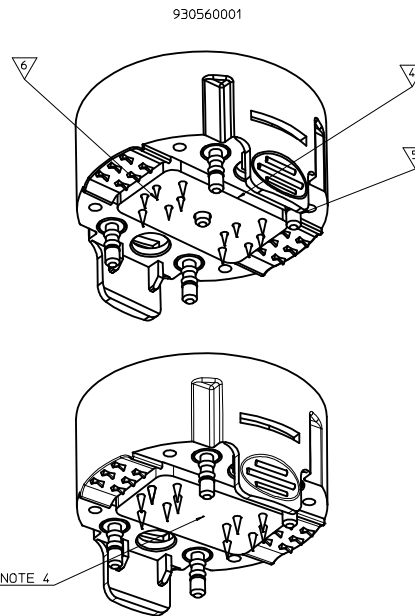
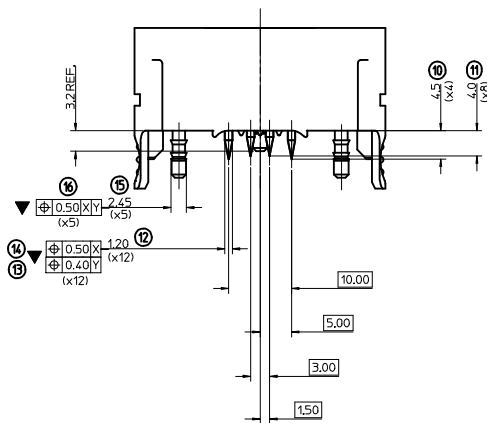
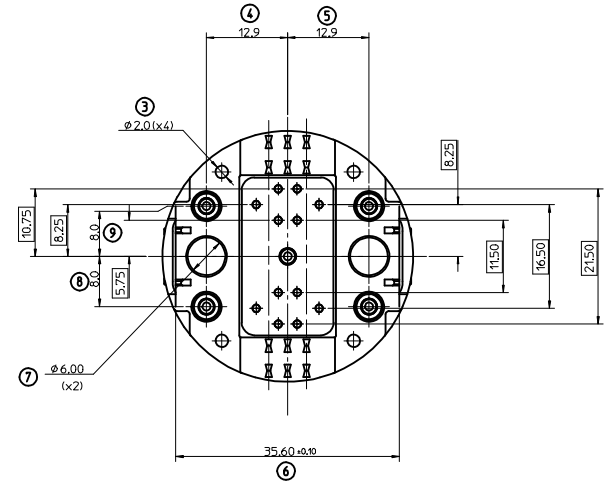
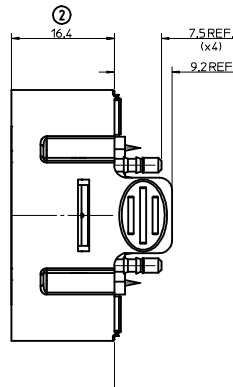

930560090

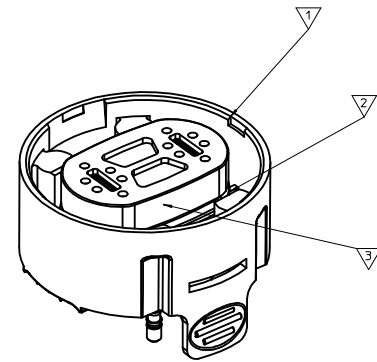

COMPONENT	DESCRIPTION
1	CABLE CONNECTOR TOP PBT 30% GF, COLOUR BLACK
2	CABLE CONNECTOR SEAL SILICONE RUBBER, COLOR BLACK
3	CABLE CONNECTOR SLEEVE PBT 30% GF, COLOUR BLACK
4	CABLE CONNECTOR TOP GEL MAT SUSPENDED LIQUID SILICONE, COLOUR BLUE
5	CABLE CONNECTOR STUD BRASS
6	CABLE CONNECTOR PIN PHOSPHOR BRONZE PLATING: NICKLE ALL OVER Au OVER PdNi IN SELECTED AREAS

NOTES

- SEE CHART FOR MATERIAL AND PLATING INFORMATION
- PACKAGING: SEE PK-93056-001
- SEE PRODUCT SPEC PS-93056-001
- AS 930560001 WITHOUT THE CENTER STUD LOADED
- POLARIZING FEATURE

LAST INSPECTION NUMBER 35

PART NUMBER	DESCRIPTION
930560001	CABLE CONNECTOR MODULE
930560090	CABLE CONNECTOR MODULE, NO CENTER STUD, POLARIZED

ADDED OPTION EC NO: IPG2015-185Z DRWNG:DMAHER 2015/04/13 CHKD: APPR:STR/GRFF:IN 2015/08/19 REV:	QUALITY SYMBOLS ▽=2 ▽=0	GENERAL TOLERANCES (UNLESS SPECIFIED) mm INCH 4 PLACES ± --- ± --- 3 PLACES ± --- ± --- 2 PLACES ± 0.15 ± --- 1 PLACE ± 0.3 ± --- ANGULAR ± 2°	DIMENSION STYLE MM ONLY	SCALE 2.5:1	DESIGN UNITS METRIC	THIRD ANGLE PROJECTION
	DRAWN BY DMAHER	DATE 7/11/2007	CHECKED BY MSHANAHAN	DATE 7/11/2007	APPROVED BY EFOLAN	DATE 7/11/2007
MATERIAL NO.		SEE TABLE		DOCUMENT NO.		SHEET NO.
DRAFT WHERE APPLICABLE MUST REMAIN WITHIN DIMENSIONS		THIS DRAWING CONTAINS INFORMATION THAT IS PROPRIETARY TO MOLEX INCORPORATED AND SHOULD NOT BE USED WITHOUT WRITTEN PERMISSION		MOLEX INCORPORATED		1 OF 3
SD-93056-001						

COMPONENT	DESCRIPTION
1	CABLE CONNECTOR BASE PBT 30% GF, COLOUR BLACK
2	CABLE CONNECTOR BASE GEL MAT SUSPENDED LIQUID SILICONE, COLOUR BLUE

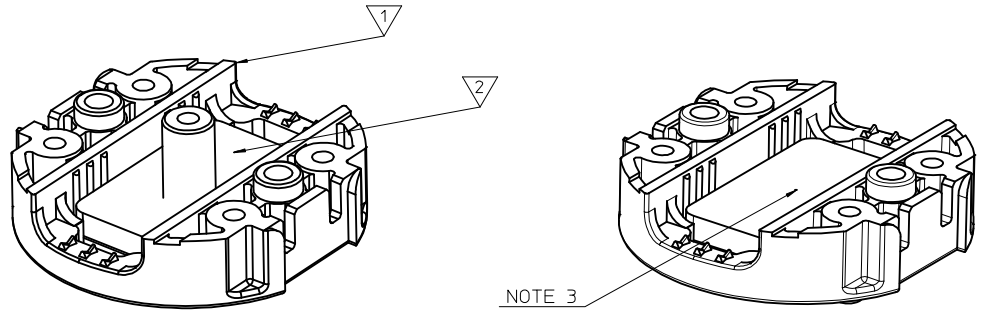

930560051

930560055

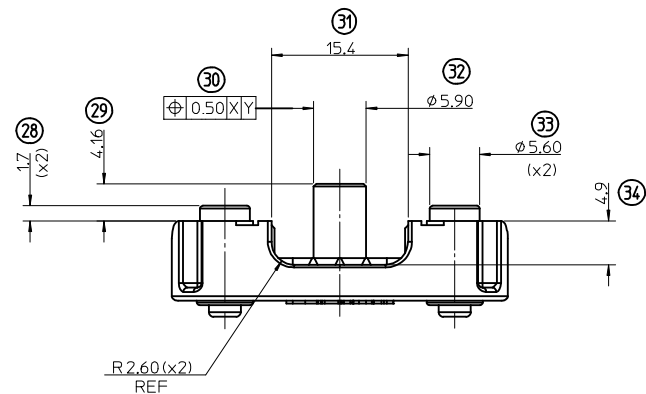
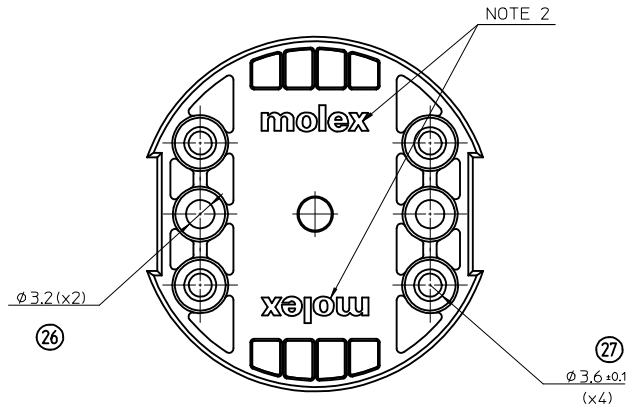
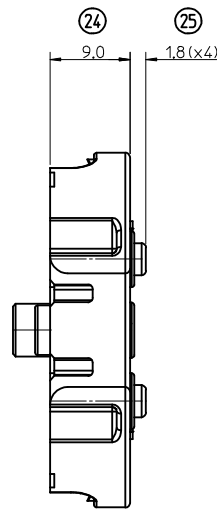
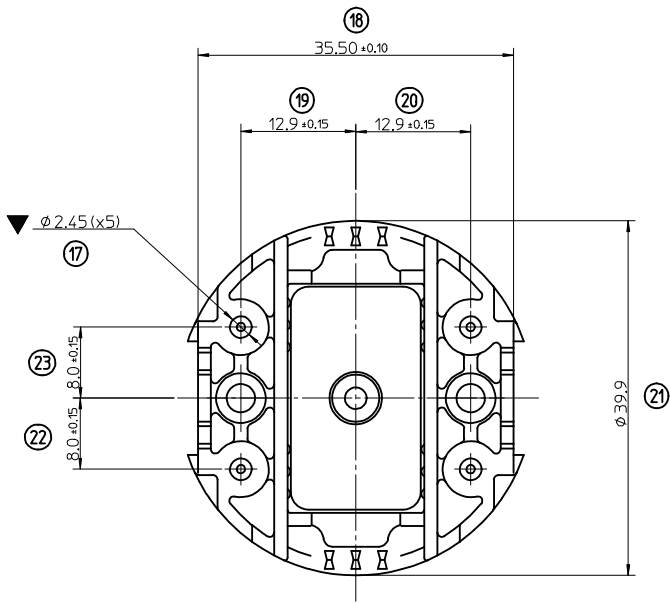

NOTES

- SEE CHART FOR MATERIAL INFORMATION
- LOGO EMBOSSED 0.3 MM TYP
- AS 930560051 WITHOUT CENTRE POST

PART NUMBER	DESCRIPTION
930560051	CABLE CONNECTOR BASE WITH POST
930560055	CABLE CONNECTOR BASE WITHOUT POST

REV	DESCRIPTION	QUALITY SYMBOLS	GENERAL TOLERANCES (UNLESS SPECIFIED)		DIMENSION STYLE		SCALE	DESIGN UNITS	THIRD ANGLE PROJECTION
			mm	INCH	MM ONLY	2.5:1	METRIC	THIRD ANGLE PROJECTION	
ADDED OPTION	EC NO: IFC2015-1852	▽=1	4 PLACES ± ---	± ---	DRAWN BY	DATE	TITLE	CABLE CONNECTOR MODULE	
D	DRWN:DMAHER 2015/04/23	▽=0	3 PLACES ± ---	± ---	DMAHER	7/11/2007			
	CHKD:		2 PLACES ± 0.15	± ---	CHECKED BY	DATE		MOLEX INCORPORATED	
	APPR:STIGLFFIN 2015/08/19		1 PLACE ± 0.3	± ---	MSHANAHAN	7/11/2007			
			ANGULAR ± 2 °		APPROVED BY	DATE		SD-93056-001	
					EFOLAN	7/11/2007			
			DRAFT WHERE APPLICABLE MUST REMAIN WITHIN DIMENSIONS		MATERIAL NO.			SHEET NO. 2 OF 3	
					SEE TABLE				
			THIS DRAWING CONTAINS INFORMATION THAT IS PROPRIETARY TO MOLEX INCORPORATED AND SHOULD NOT BE USED WITHOUT WRITTEN PERMISSION						

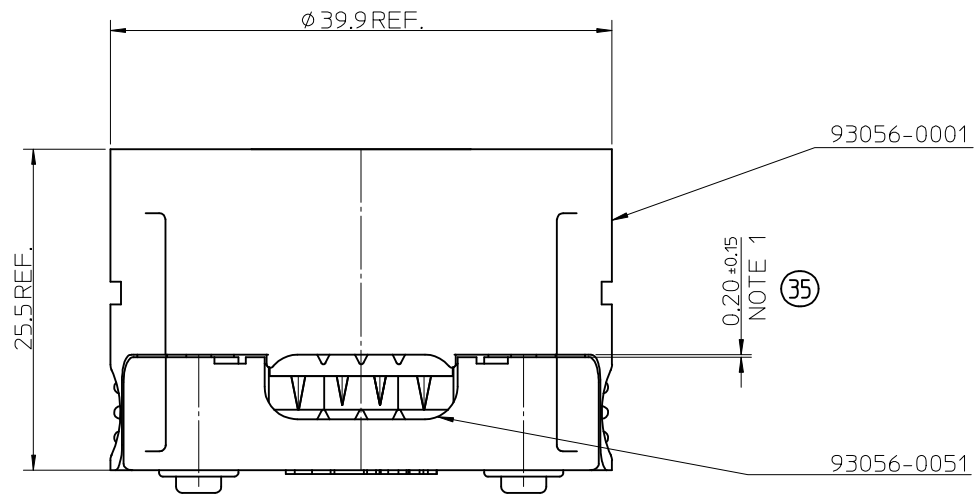

MATING OF 93056-0001 WITH 93056-0051
OR 93056-0090 WITH 93056-0055

NOTE

1: DIMENSION TO ENSURE CORRECT MATING DISTANCE FOR CONNECTORS

SEE SHEET 1 EC NO: IPG2015-1852 DRW:DMAHER 2015/04/23 CHKD: APPR:STGRIFFIN 2015/08/19	DESCRIPTION REV	QUALITY SYMBOLS	GENERAL TOLERANCES (UNLESS SPECIFIED)		DIMENSION STYLE MM ONLY		SCALE 5:1	DESIGN UNITS METRIC	THIRD ANGLE PROJECTION	
		$\nabla = 0$ $\square = 0$	mm	INCH	DRAWN BY DMAHER	DATE 7/11/2007	TITLE CABLE CONNECTOR MODULE			
		4 PLACES	± ---	± ---	CHECKED BY MSHANAHAN	DATE 7/11/2007				
			3 PLACES	± ---	± ---	APPROVED BY EFOLAN	DATE 7/11/2007	MATERIAL NO. 930560100		DOCUMENT NO. SD-93056-001
	2 PLACES	± 0.15	± ---	ANGULAR ± 2 °		SHEET NO. 3 OF 3				
	1 PLACE	± 0.3	± ---	DRAFT WHERE APPLICABLE MUST REMAIN WITHIN DIMENSIONS		THIS DRAWING CONTAINS INFORMATION THAT IS PROPRIETARY TO MOLEX INCORPORATED AND SHOULD NOT BE USED WITHOUT WRITTEN PERMISSION				