

## Introduction

The ISL55036EVAL1Z evaluation board is a design platform containing all the circuitry needed to characterize critical performance parameters of the ISL55036, Six-channel high-speed op amps, using a variety of user defined test circuits.

The ISL55036 amplifiers are 400MHz GBW operational amplifiers featuring single supply operation over a voltage range of 3VDC to 5.5VDC and slew rate of 2500V/μs into a 150Ω load. ISL55036 has an internal gain of 4.

## Ordering Information

- ISL55036EVAL1Z

## Reference Documents

- ISL55036 Data Sheet, FN6640.

## Evaluation Board Key Features

The ISL55036EVAL1Z is designed to enable the IC to operate from a single supply (+3VDC to +5.5VDC). The board is configured for 75Ω load impedance which is suitable for driving video cables.

## Power Supplies

External power connections are made through the +V and Ground connections on the evaluation board. De-coupling capacitor C<sub>1</sub> reduces the voltage rate-of-rise to less than

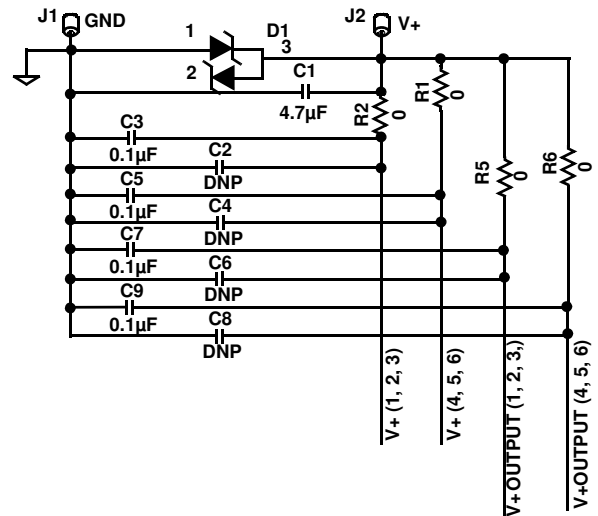

FIGURE 1. POWER SUPPLY

1V/μs during power-up. Four additional Capacitors, C<sub>3</sub>, C<sub>5</sub>, C<sub>7</sub> and C<sub>9</sub> are placed close to the IC and provide additional high frequency filtering. Anti-reverse diode D<sub>1</sub> protects the circuit in the case of accidental polarity reversal. (See Figure 1).

## Amplifier Configuration

ISL55036 contains six high-speed op-amps, which are separated into two groups of three op-amps each. Each group is controlled by its own enable pin. The schematic in Figure 2 shows one of the six op-amps with the components supplied. The circuit implements a series 75Ω back-termination for driving 75Ω cables.

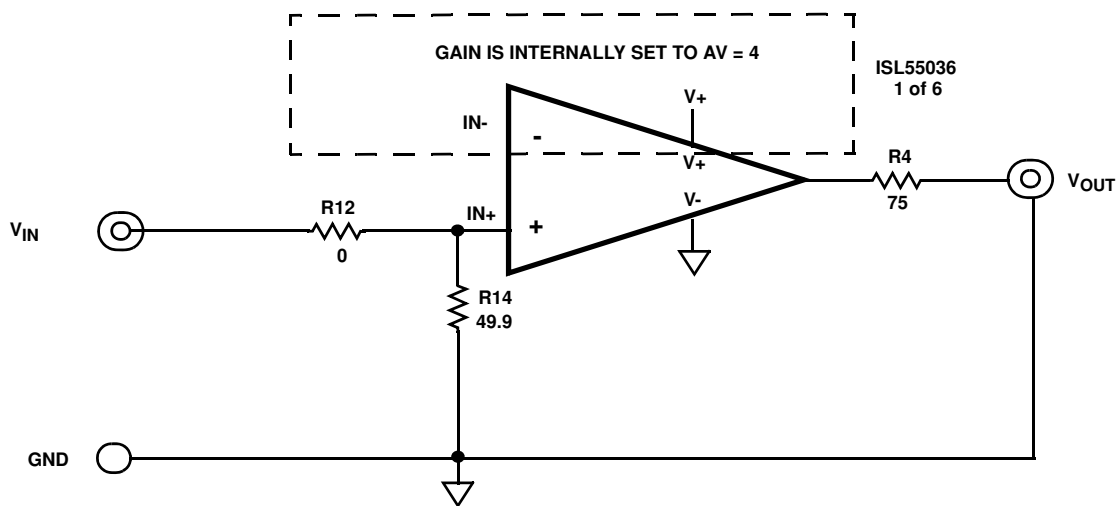

FIGURE 2. BASIC AMPLIFIER CONFIGURATION

### User-selectable Options

Component pads are included to enable a variety of user-selectable circuits to be added to the amplifier outputs. The output has additional resistor and capacitance placements for loading as shown in Figure 3:

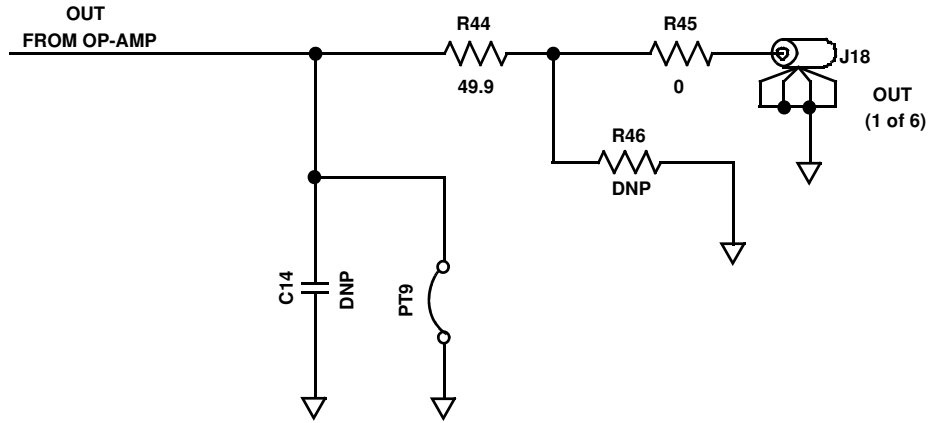
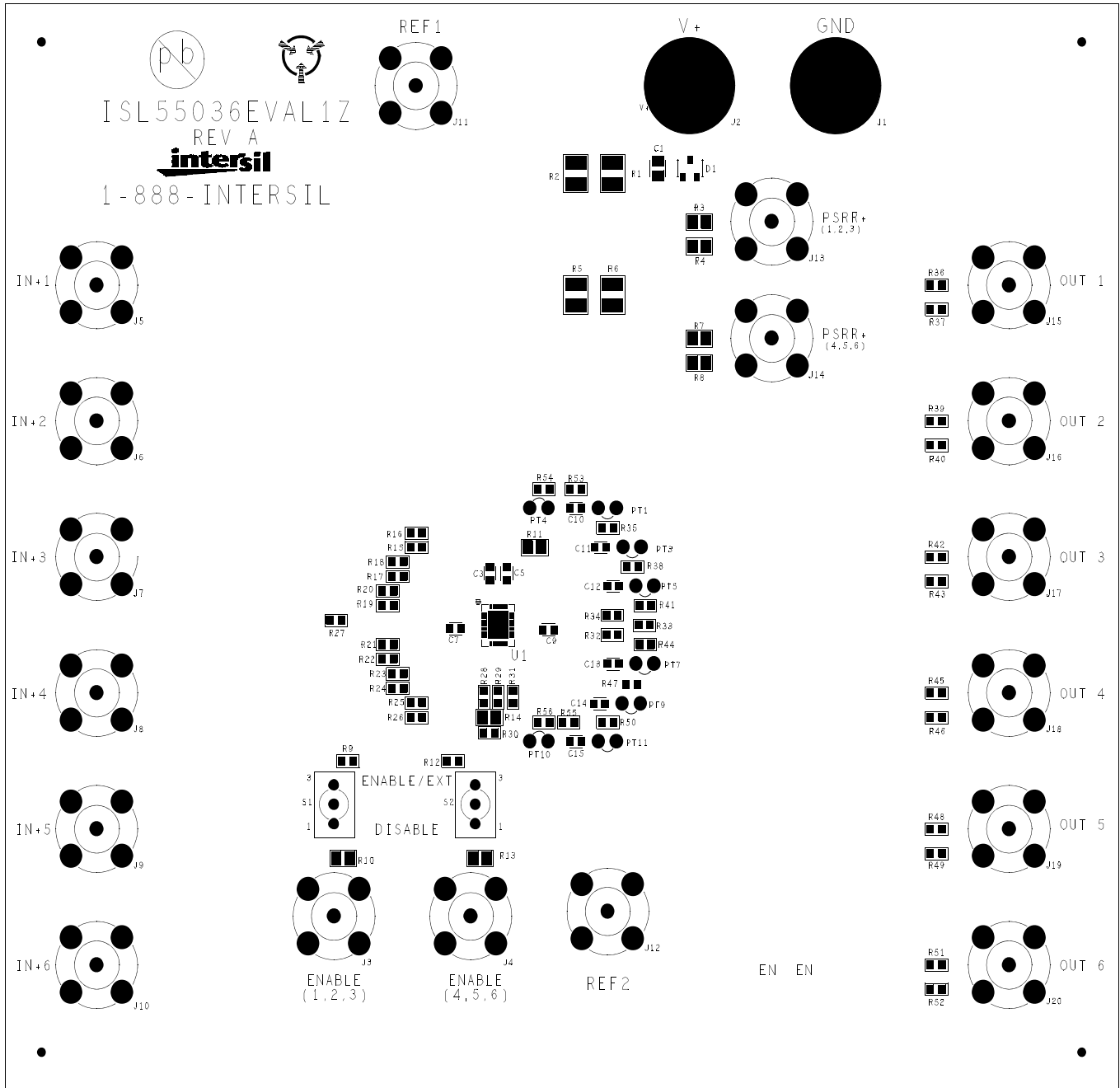

FIGURE 3. OUTPUT STAGE

### ISL55036EVAL1Z Components Parts List

DEVICE NUMBER	DESCRIPTION	COMMENTS
C1	CAP-TANTALUM, SMD, D, 4.7μF, 50V, 10%. LOW ESR, ROHS	Power Supply Decoupling
C3, C5, C7, C9	CAP, SMD, 0603, .01μF, 25V,10%, X7R, ROHS	Power Supply Decoupling
C2, C4, C6, C8	CAP, SMD, 0603,1000pF, 25V,10%, X7R, ROHS	Power Supply Decoupling Not populated
C10 to C15	CAP, SMD, 0603, DNP-PLACE HOLDER	User selectable output capacitors Not populated
D1	DIODE-RECTIFIER, SMD, SOD-123, 2P, 40V, 0.5A, ROHS	Reverse Power Protection
U1 (ISL55036EVAL1Z)	ISL55036FUZ, IC- OP AMP, 24P, QFN, ROHS	
R3, R4, R7, R8, R53-R56	RESISTOR, SMD, 0603, 0.1%, MF, DNP-PLACE HOLDER	For internal use only Not populated
R11, R14, R37, R40, R43,R46, R49, R52	RESISTOR, SMD, 0603, 0.1%, MF, DNP-PLACE HOLDER	User selectable resistors Not populated
R11, R2, R5, R6, R15, R17, R19, R21, R23, R25, R27 to R34, R36, R39, R42, R45, R48, R51, R64	RES, SMD, 0603, 0Ω, 1/16W, tF, ROHS	0Ω user selectable resistors
R10, R13, R16, R18, R20, R22, R24, R26	RES, SMD, 0603, 49.9Ω, 1/10W, 1%, tF, ROHS	Input resistors
R11, R12	RES, SMD, 0603, 75Ω, 1/8W, 1%, tF, ROHS	Output series resistors
R9, R10	RES, SMD, 0603, 10k, 1/10W, 1%, tF, ROHS	Enable pull-up resistors

ISL55036EVAL1Z Top View



Intersil Corporation reserves the right to make changes in circuit design, software and/or specifications at any time without notice. Accordingly, the reader is cautioned to verify that the Application Note or Technical Brief is current before proceeding.

For information regarding Intersil Corporation and its products, see [www.intersil.com](http://www.intersil.com)

# ISL55036EVAL1Z Schematic Diagram

