

SYM	REVISION DESCRIPTION	DFTM	DATE	APPD	APPD
A	RELEASED FOR PRODUCTION	Monica	2018.09.12	Joslen	2018.09.12

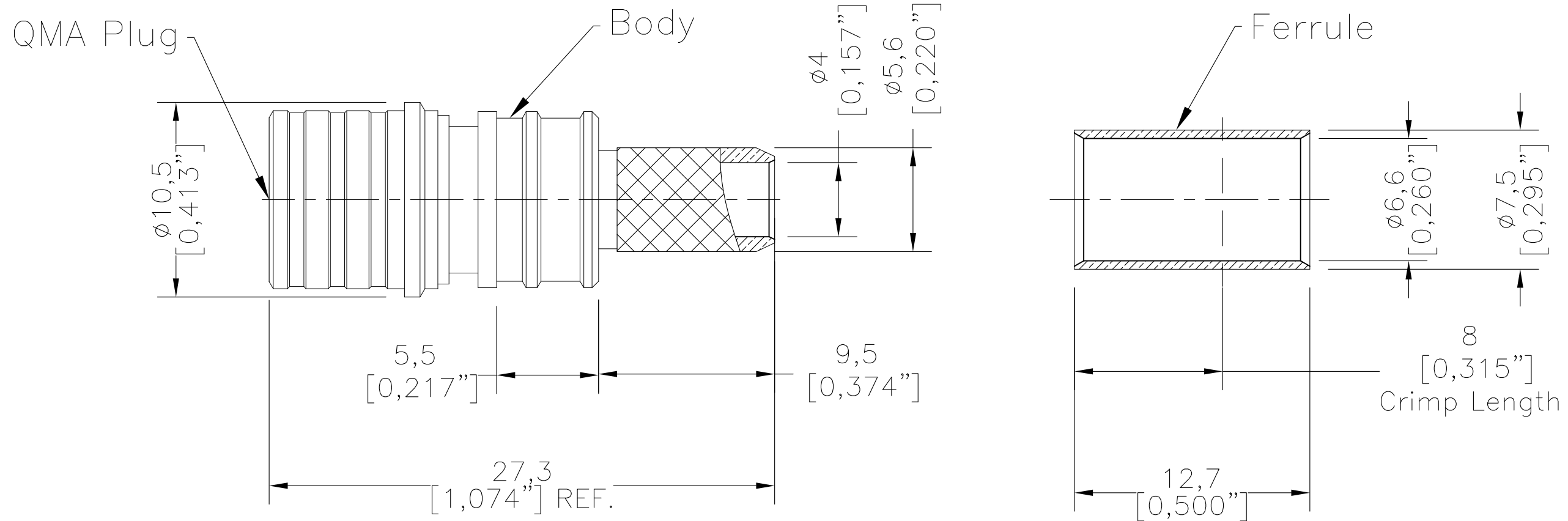

I. MATERIALS & FINISHES

Components	Materials	Finishes	Thk. (μ")
Body	Brass	Albaloy	80
Center Cont.	Beryllium Copper	Gold	50
Ferrule	Copper	Albaloy	80
Nut	Brass	Albaloy	80
Insulator	PTFE	--	--
Gasket	Silicone	--	--

II. ELECTRICAL PROPERTIES

Impedance (Ω):	50
Frequency Range (GHz):	DC to 8 GHz
Dielectric Withstanding Voltage (V):	1000
Insulation Resistance (MΩ):	≥50000
VSWR:	≤1.30
Insertion Loss(dB, f/GHz):	-0.1x √f

III. ENVIRONMENT PROPERTIES

Temperature Range:	-40°C~+125°C
Thermal Shock:	MIL-STD 202G, Meth.107, Cond.B
Vibration:	MIL-STD 202G, Meth.204, Cond.D
Shock:	MIL-STD 202G, Meth.213, Cond I
Climatic Class:	IEC 60068 40/85/21
(2002/95/EC)RoHS:	Compliant

IV. MECHANICAL PROPERTIES

Center Cont.:	Finger Contact
Outer Cont.:	Crimp
Coupling Nut Torque (N.m):	N/A
Cbl-Connector Retention Force (N):	250
Durability (cycles):	100

V. TOOLING

Stripping Tool: 3192-152/CST-240A
Crimping Tool: 3190-667/CT-240/200/100

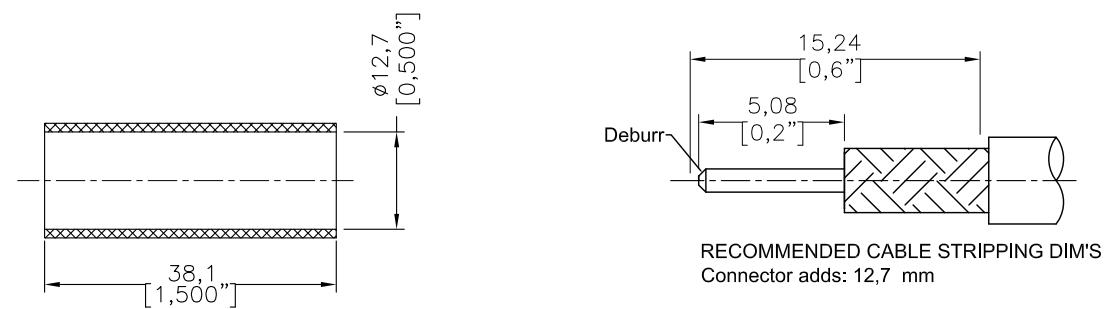

Shrink Tube (1/2"x1.5" 3:1)

RECOMMENDED CABLE STRIPPING DIM'S
Connector adds: 12.7 mm

Compatible with Standard: QLF

MATL:	UNLESS OTHERWISE SPECIFIED	DFTM. Monica	TIMES MICROWAVE SYSTEMS An Amphenol Company			
USED ON: O	ALL DIMENSIONS ARE IN mm MACHINED SURFACES FINISH 1.6 RMS MAX. REMOVE ALL BURRS 0.15X45° MAX. BREAK MACHINE CORNERS 0.15X45° D MAX. FILLET R. TOLERANCES ON DECIMALS .X ±0.3 .XX ±0.15 ANGLES ±2° FRACTIONS ± N/A	DATE 2018.09.12	EZ-240-QM-X QMA Male (Plug) Straight Non-Solder Pin No Braid Trim Connector for LMR-240 Cable			
SCALE: N/A DWG SIZE A4		CHKD Patrick				
DO NOT SCALE DRAWING		DATE 2018.09.12				
CODE IDENT 68999		APPD Joslen				
		DATE 2018.09.12	SHEET 1 OF 1	3190-6564	REV A	