

REVISIONS				
P	LTR	DESCRIPTION	DATE	APVD
R1		REVISION PER ECN-22-167492	08/01/22	JM JM

1. THIS RECEPTACLE WILL MATE WITH ANY 17C2, SIZE 3 PLUG IN AMPLIMITE SERIES.
2. MAXIMUM WIRE INSULATION TO BE USED WITH THIS RECEPTACLE IS  $\phi.068$ .
3. THIS CONNECTOR ACCEPTS (2) POWER 8, OR COAX SOCKET CONTACTS IN POSITIONS A1 THRU A2, PURCHASED SEPARATELY.
4. THIS CONNECTOR ACCEPTS SIZE 20 SOCKET SIGNAL CONTACTS IN POSITIONS 1 THRU 15, PURCHASED SEPARATELY.

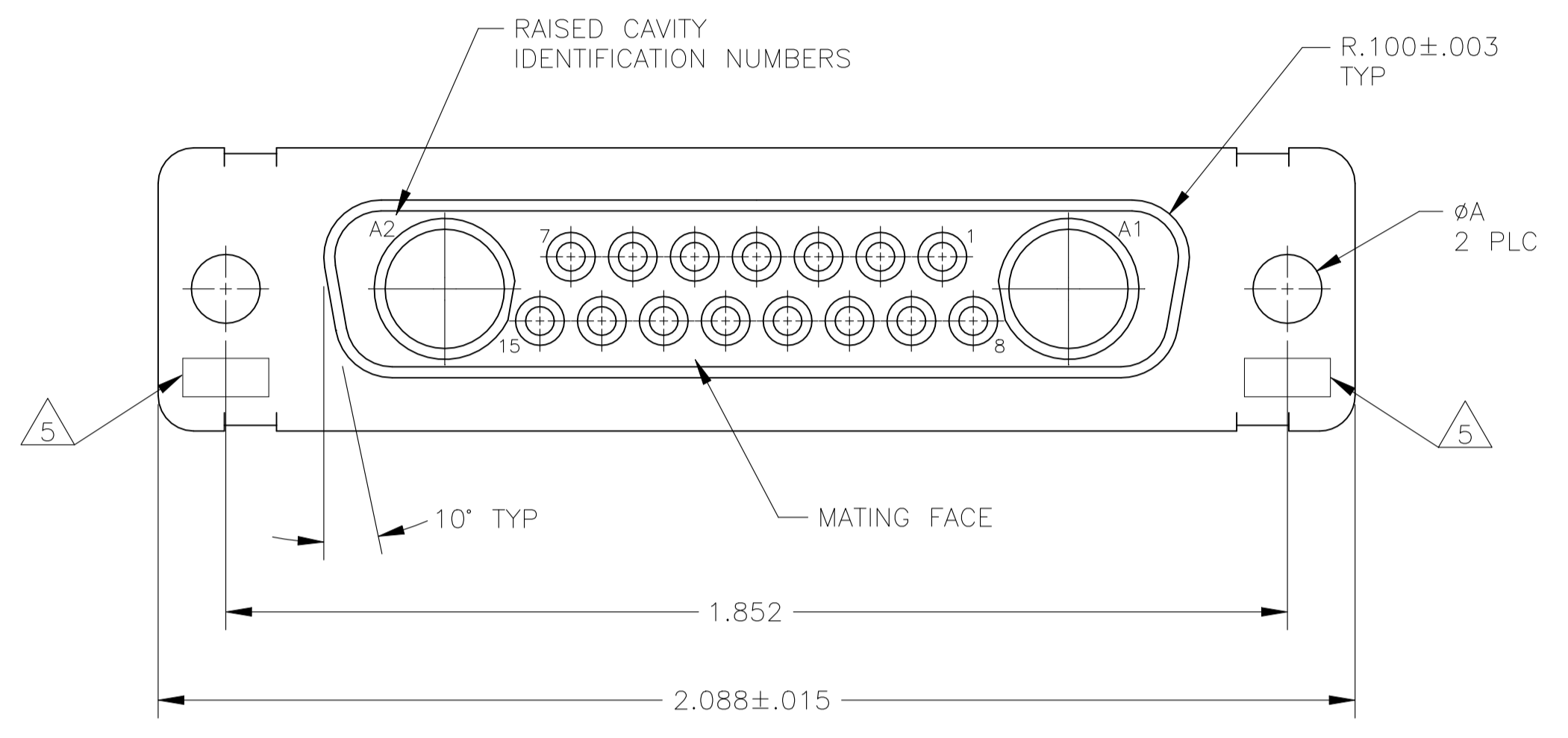

- 5. UL/CSA DESIGNATION STAMPED IN THIS AREA, OPTIONAL.
- 6. STEEL PER ASTM-A-109.
- 7. BRASS PER MIL-C-50 AND ASTM-B-36 UNS NO. C26000.
- 8. FINISH: CADMIUM PLATED PER QQ-P-416.
- 9. GOLD PLATED PER MIL-G-45204 TYPE II, GRADE C, CLASS 1 OVER COPPER PER MIL-C-14550, CLASS IV.
- 10. FINISH: TIN PER ASTM-B-545 .000400 MIN THK OVER COPPER PER AMS2418 .000050 MIN THK.
- 11. FINISH: ZINC PLATE PER ASTM-B-633 .000200-.000400 THK WITH SUPPLEMENTARY CHROMATE (Cr3+).

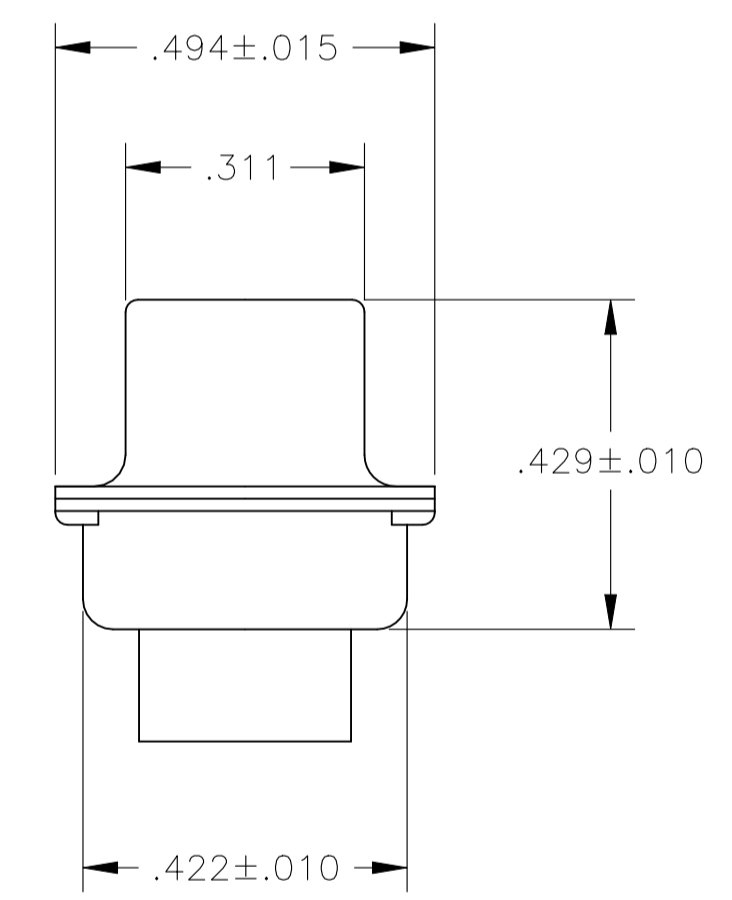
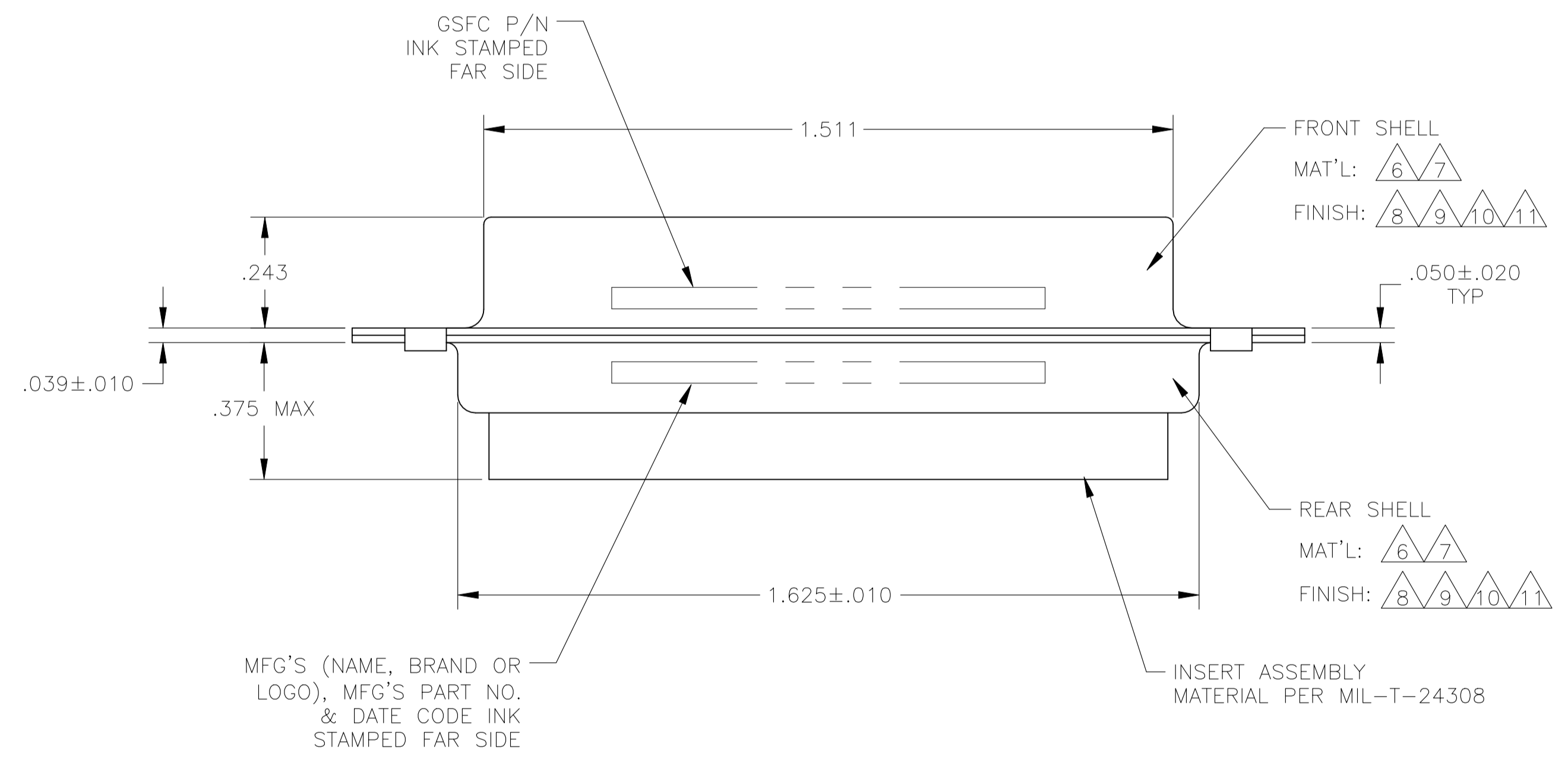

6, 11	.120	-	5-212510-1
6, 10	.120	-	5-212510-4
6, 10	.120	-	212510-5
6, 10	.120	-	212510-4
7, 9	.154	311P405-13S-B-15	212510-3
7, 9	.120	311P405-13S-B-12	212510-2
6, 8	.120	-	212510-1
REMARKS	ØA	GSFC P/N	PART NO.

THIS DRAWING IS A CONTROLLED DOCUMENT.

DIMENSIONS: INCHES	TOLERANCES UNLESS OTHERWISE SPECIFIED:	DIN C.C.THOMAS 26JAN88	APVD A.EMADI 02FEB88	NAME RECEPTACLE ASSEMBLY AMPLIMITE 17C2 SIZE 3, SERIES 109, COAX MIX
0. PLC ± -	1. PLC ± -	2. PLC ± -	3. PLC ± .005(0.13)	4. PLC ANGLES ± # 0°, 90°
MATERIAL -	FINISH -	WEIGHT 0.000000	SIZE A1	CAGE CODE 00779
CUSTOMER DRAWING		SCALE 4:1	SHEET 1 of 1	REV R1

TE Connectivity