

LOC		DIST		REVISIONS			
P	LTR	DESCRIPTION	DATE	DMN	APVD		
R4	REV PER ECO-13-007388		17DEC2013	BC	AS		

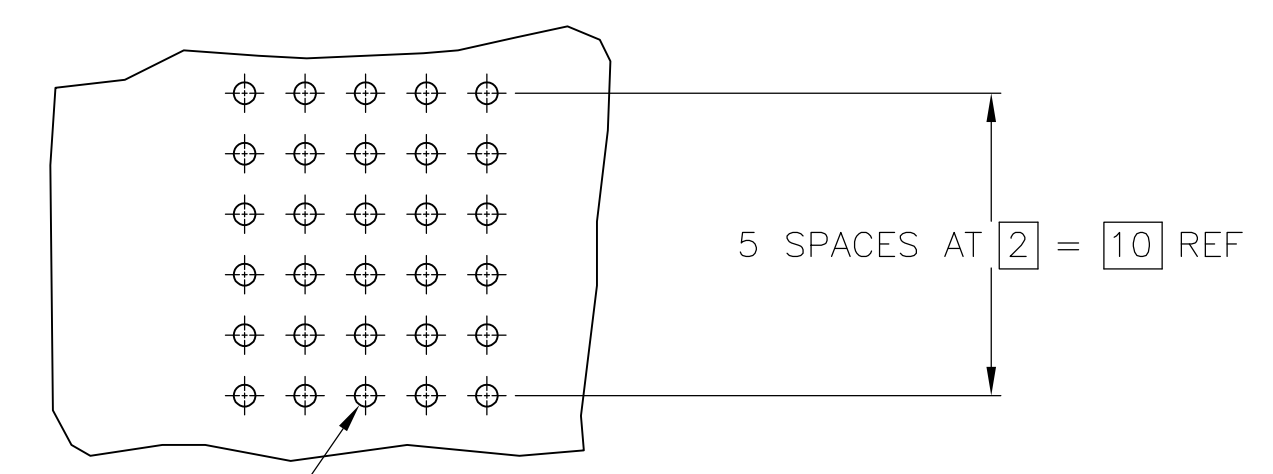
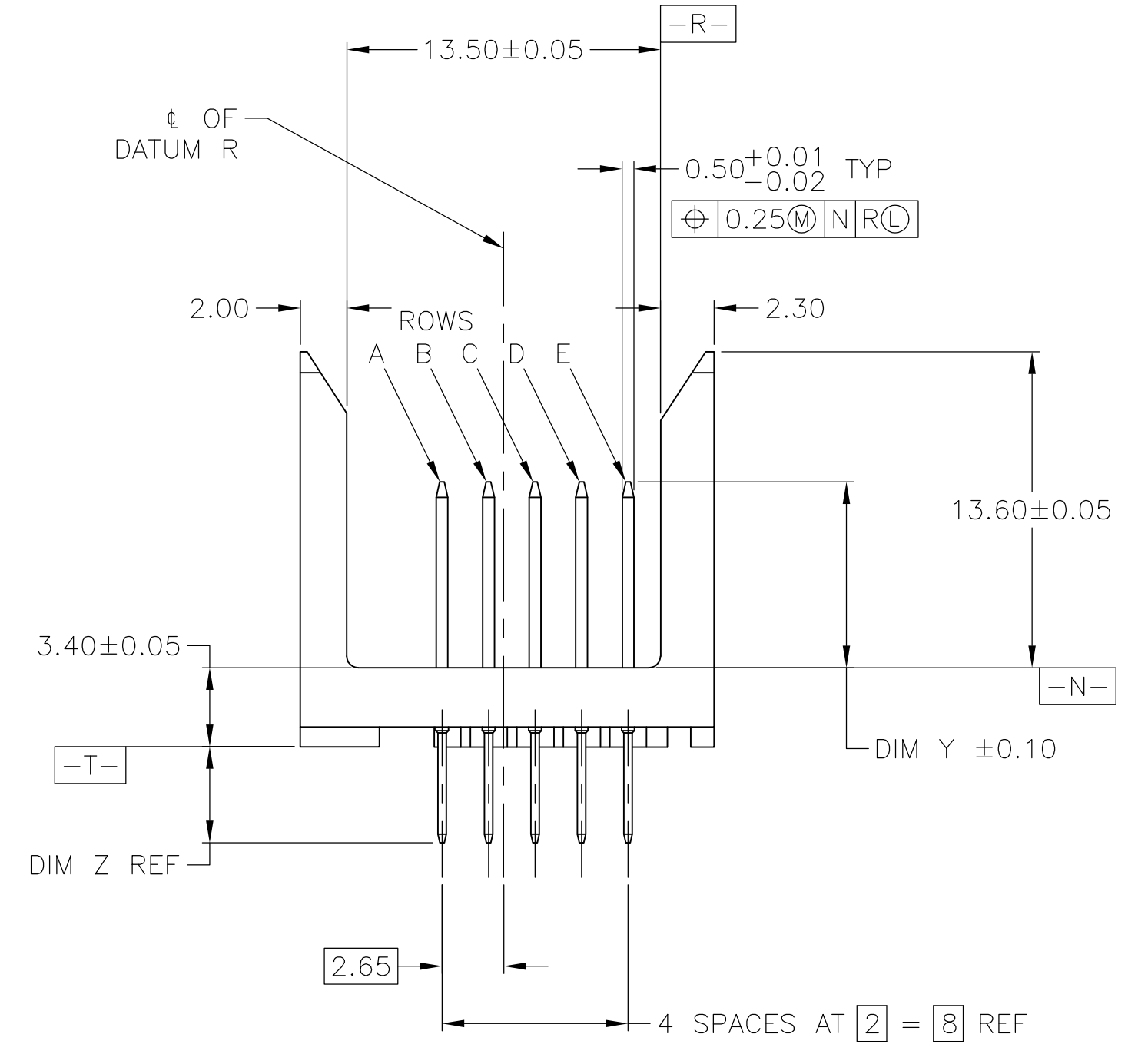
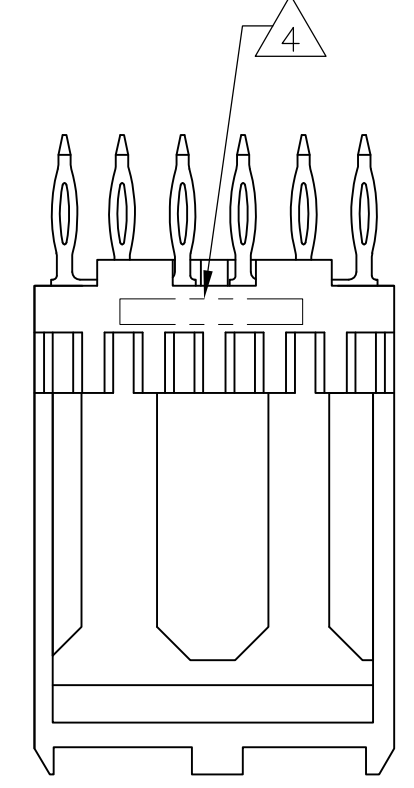
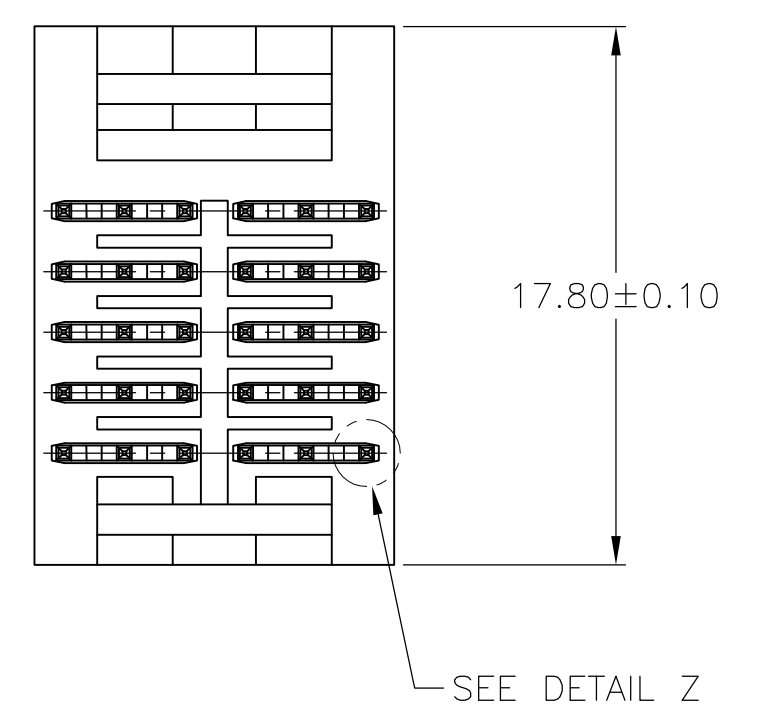
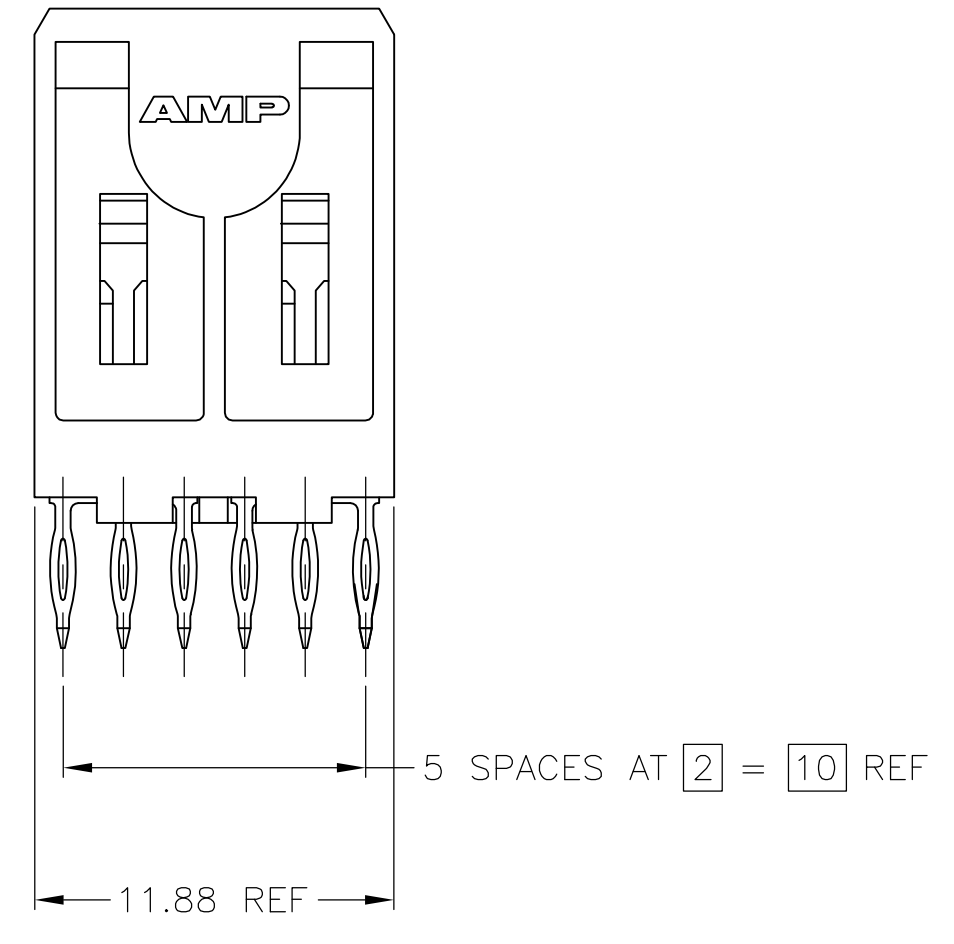
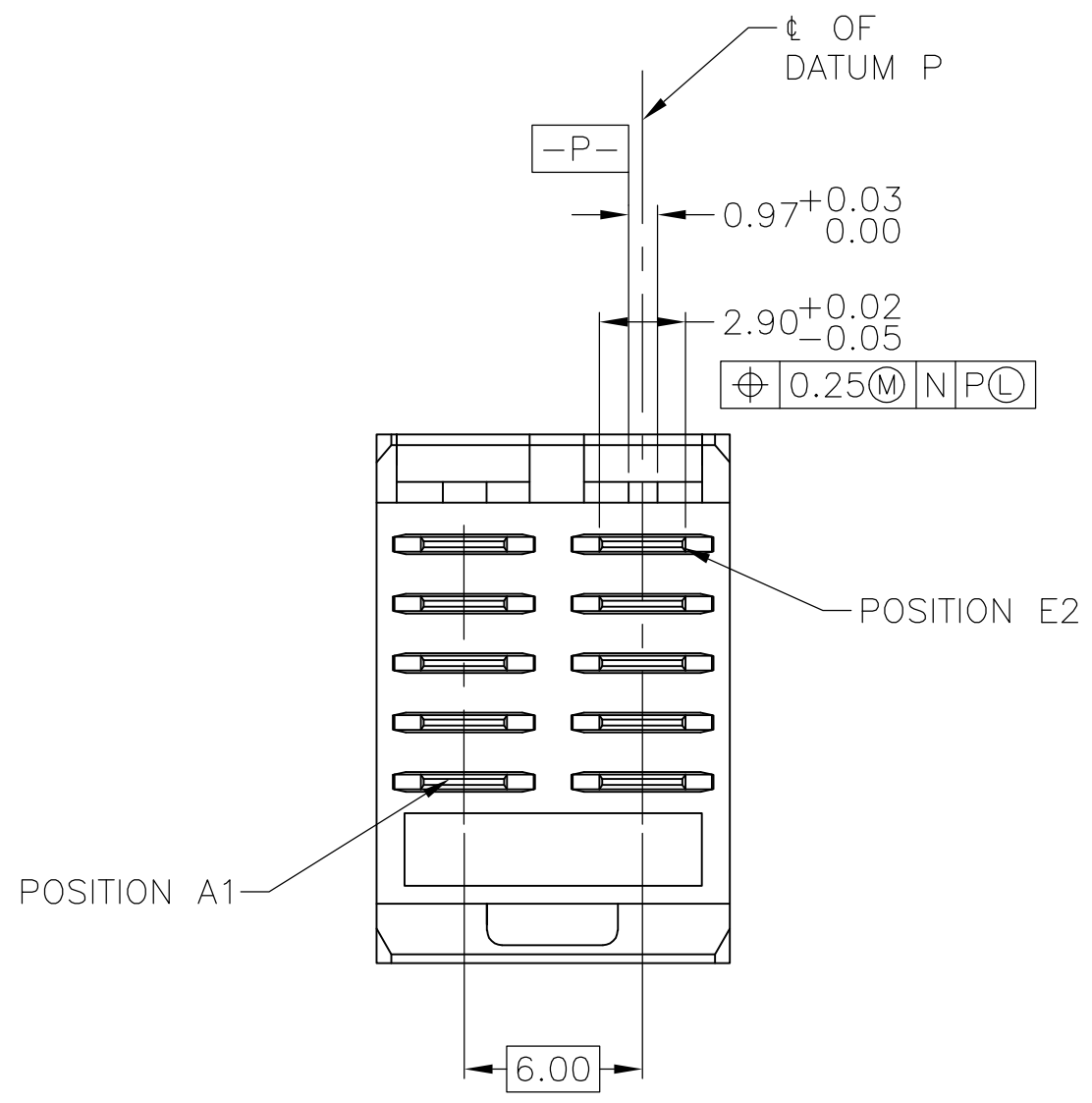

Ø0.725±0.075  
PLATED THROUGH HOLE  
30 PLC  
Ø0.15(M)

RECOMMENDED CIRCUIT PATTERN  
PER IPC-D300 TYPE II, CLASS C  
(COMPONENT SIDE)

- 1 HOUSING MATERIAL: LIQUID CRYSTAL POLYMER, NATURAL.
- 2 CONTACT MATERIAL: COPPER ALLOY.
- 3 CONTACT FINISH:  
UNDERPLATE (ENTIRE CONTACT):  
0.00127 MIN NICKEL PER SAE-AMS-QQ-N-290  
ON MATING SURFACES:  
FLASH GOLD PER ASTM B 488, OVER  
0.00076 MIN PALLADIUM-NICKEL OVER UNDERPLATE, OR  
0.00076 MIN GOLD PER ASTM B 488 OVER UNDERPLATE.  
ON LEADS:  
0.00127 MIN TIN-LEAD OVER UNDERPLATE.  
LUBRICATION (MIN MATING SURFACES):  
SURFACE CONDITIONER AFTER PLATING.
- 4 PART NUMBER AND DATE CODE IN APPROXIMATE AREA AS SHOWN.
- 5 OBSOLETE PARTS: OBSOLETE CIS STREAMLINING PER D.RENAUD/D.SINISI

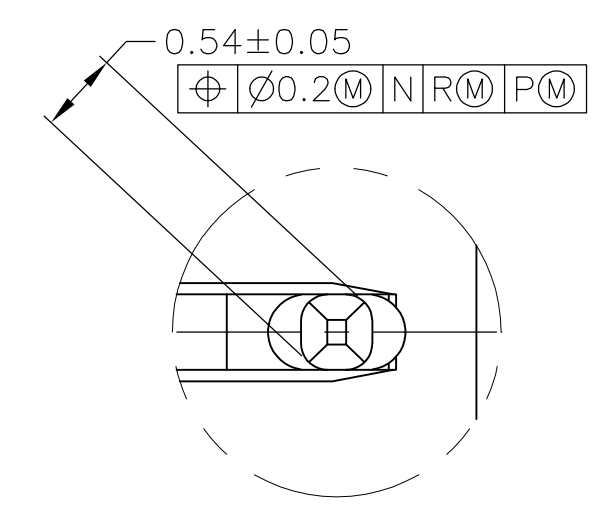

DETAIL Z  
SCALE 20:1

THIS DRAWING IS A CONTROLLED DOCUMENT.		DIN T. SHUEY 1-7-98		TE Connectivity	
DIMENSIONS: mm		CHK W. MILLHIMES 1-16-98			
TOLERANCES UNLESS OTHERWISE SPECIFIED:		APVD W. MILLHIMES 1-16-98		NAME	
0 PLC ± -		PRODUCT SPEC		ASSEMBLY, PIN, VERTICAL, 5 ROW, POWER MODULE, PRESS FIT LEAD, Z-PACK 2mm FB	
1 PLC ± -		APPLICATION SPEC		SIZE CAGE CODE DRAWING NO	
2 PLC ± -		114-1075		RESTRICTED TO	
3 PLC ± -		WEIGHT		A1 00779 C=536642	
4 PLC ± -		FINISH		CUSTOMER DRAWING	
ANGLES ± -		SCALE 4:1		SHEET 1 OF 2	
FINISH		REV R4			

AD	5.00	4.25
AC	8.00	4.25
AB	7.25	4.25
AA	6.50	4.25
CONTACT LETTER	DIM Z	DIM Z

E	AA	AA	E	536642-1 OBSOLETE $\nabla$ 5
D	AA	AA	D	
C	AA	AA	C	
B	AA	AA	B	
A	AA	AA	A	
ROW	1	2	ROW	PART NUMBER

CONTACT LOAD CHART

E	AA	AA	E	536642-5 OBSOLETE $\nabla$ 5
D	AA	AA	D	
C	AA	AA	C	
B	AC	AC	B	
A	AA	AA	A	
ROW	1	2	ROW	PART NUMBER

CONTACT LOAD CHART

E	AB	AB	E	1-536642-6 OBSOLETE $\nabla$ 5
D	AB	AB	D	
C	AB	AB	C	
B	AC	AC	B	
A	AC	AC	A	
ROW	1	2	ROW	PART NUMBER

CONTACT LOAD CHART

SUPERSEDED BY 536642-4

E	AA	AA	E	536642-2
D	AA	AA	D	
C	AB	AB	C	
B	AC	AC	B	
A	AC	AC	A	
ROW	1	2	ROW	PART NUMBER

CONTACT LOAD CHART

E	AA	AC	E	536642-6 OBSOLETE $\nabla$ 5
D	AA	AC	D	
C	AA	AC	C	
B	AA	AC	B	
A	AA	AC	A	
ROW	1	2	ROW	PART NUMBER

CONTACT LOAD CHART

E	AB	AB	E	2-536642-4 OBSOLETE
D	AA	AA	D	
C	AB	AB	C	
B	AA	AA	B	
A	AB	AB	A	
ROW	1	2	ROW	PART NUMBER

CONTACT LOAD CHART

E			E	536642-3 OBSOLETE
D	AC	AC	D	
C	AB	AB	C	
B	AA	AA	B	
A	AC	AC	A	
ROW	1	2	ROW	PART NUMBER

CONTACT LOAD CHART

E	AC	AC	E	536642-7 OBSOLETE $\nabla$ 5
D	AC	AC	D	
C	AC	AC	C	
B	AC	AC	B	
A	AC	AC	A	
ROW	1	2	ROW	PART NUMBER

CONTACT LOAD CHART

E	AC	AA	E	2-536642-5 OBSOLETE $\nabla$ 5
D	AC	AA	D	
C	AC	AA	C	
B	AC	AA	B	
A	AC	AA	A	
ROW	1	2	ROW	PART NUMBER

CONTACT LOAD CHART

E	AA	AA	E	536642-4 OBSOLETE $\nabla$ 5
D	AA	AA	D	
C	AB	AB	C	
B	AC	AC	B	
A	AC	AC	A	
ROW	1	2	ROW	PART NUMBER

CONTACT LOAD CHART

E	AC	AC	E	1-536642-0 OBSOLETE $\nabla$ 5
D	AB	AB	D	
C	AD	AD	C	
B			B	
A	AC		A	
ROW	1	2	ROW	PART NUMBER

CONTACT LOAD CHART

E	AA	AA	E	2-536642-6
D	AB	AB	D	
C	AC	AC	C	
B			B	
A	AB	AC	A	
ROW	1	2	ROW	PART NUMBER

CONTACT LOAD CHART

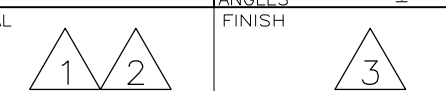
THIS DRAWING IS A CONTROLLED DOCUMENT.		DIN T. SHUEY 1-7-98	 TE Connectivity
DIMENSIONS: mm		CHK W. MILLHIMES 1-16-98	
TOLERANCES UNLESS OTHERWISE SPECIFIED:		APVD W. MILLHIMES 1-16-98	NAME
0. PLC ± - 1. PLC ± - 2. PLC ± - 3. PLC ± - 4. PLC ± - ANGLES ± -		PRODUCT SPEC 108-1441	ASSEMBLY, PIN, VERTICAL, 5 ROW, POWER MODULE, PRESS FIT LEAD, Z-PACK 2mm FB
MATERIAL		APPLICATION SPEC 114-1075	RESTRICTED TO
FINISH		WEIGHT	SCALE 4:1 SHEET 2 OF 2 REV R4
		CUSTOMER DRAWING	SIZE CAGE CODE DRAWING NO A1 00779 C=536642