

PART NUMBER	REVISION	DESCRIPTION	FEED TYPE
2151019-1	K	FINE CRIMP HEIGHT ADJUST	MECHANICAL
2151019-2	K	FINE CRIMP HEIGHT ADJUST	PNEUMATIC
5-2151019-1	K	STRIPPER SEAL TERMINATING UNIT	MECHANICAL
5-2151019-2	K	STRIPPER SEAL TERMINATING UNIT	PNEUMATIC
7-2151019-1	K	MECHANICAL AND CRIMP TOOLING KIT	MECHANICAL
7-2151019-2	K	PNEUMATIC AND CRIMP TOOLING KIT	PNEUMATIC
7-2151019-7	E	CRIMP TOOLING KIT	-

ATLANTIC VERSION TERMINATOR INTERFACE ADAPTER

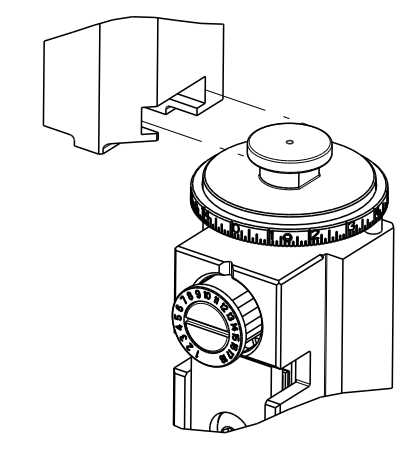

APPLICATOR DATA		
CRIMP	SIZE	TYPE
WIRE	1.78 mm [.070]	F
INSUL	2.54 mm [.100]	F

APPLICATOR INSTRUCTIONS  
408-35042

TERMINAL DATA: TE TERMINAL		TE CRIMP SPECIFICATION	
TERMINAL NAME: PIN/SOCKET, MATE-N-LOK			
WIRE STRIP LENGTH 3.96-4.75 mm [.156-.187 IN]		INSULATION DIAMETER RANGE Ø1.02-2.54 mm [.040-.100 IN]	
TERMINAL APPLICATION SPECIFICATION (A)114-1010	(C)114-1012	(B)114-1011	-

TERMINALS APPLIED			
TE TERMINAL	TE TERMINAL	TE TERMINAL	TE TERMINAL
(C) 61115-1	(C) 61314-1	(B) 350560-1	(A) 350570-7
(C) 61116-1	(C) 61314-2	(B) 350561-1	(A) 350699-1
(C) 61116-2	(C) 61314-3	(B) 350561-2	(A) 350699-2
(C) 61116-3	(C) 61314-4	(B) 350561-3	(A) 350699-3
(C) 61116-4	(C) 61314-5	(B) 350561-5	(A) 350699-5
(C) 61116-5	(C) 61314-6	(B) 350561-7	(A) 350699-7
(C) 61116-6	(C) 61314-7	(B) 350561-8	(A) 350699-8
(C) 61116-7	(C) 61314-8	(A) 350570-1	(A) 350851-1
(C) 61116-8	(C) 61527-2	(A) 350570-2	(A) 350851-2
(C) 61116-9	(C) 170147-1	(A) 350570-3	(A) 350851-7
(C) 1-61116-3	(C) 170147-2	(A) 350570-6	

WIRE SIZE	CRIMP HEIGHT mm [INCH]	CRIMP HEIGHT REFERENCE SETTING
18 AWG	1.22+/-0.05 [1.048+/-0.002]	6.1
20 AWG	1.09+/-0.05 [1.043+/-0.002]	7.7
22 AWG	1.02+/-0.05 [1.040+/-0.002]	8.4
24 AWG	0.96+/-0.05 [1.038+/-0.002]	8.8

- 1 RECOMMENDED SPARE PARTS
- 2 REFER TO SUPPLIED INSTRUCTION SHEET FOR CLEANING, LUBRICATION & STORAGE OF APPLICATOR.
- 3 APPLY PART NUMBER 1-23419-5 LOCTITE TO THREADS OF ITEM 180. APPLY PART NUMBER 2-23419-6 LOCTITE TO THREADS OF ITEM 242.
- 4 CRIMP HEIGHT REFERENCE SETTING WAS THE SETTING USED WHEN THE APPLICATOR WAS QUALIFIED AT THE FACTORY. ADJUSTMENT MAY BE NECESSARY WHEN RUNNING APPLICATOR IN THE FIELD.
- 5. UNLESS SPECIFIED OTHERWISE TORQUE VALUES SHALL BE USED PER DOCUMENT, 101-35000.

**\*WARNING**  
 ON INSTALLATION, SET WIRE DISC TO CRIMP HEIGHT REFERENCE SETTING FOR LARGEST WIRE SIZE. CRIMP HEIGHT REFERENCE SETTINGS GREATER THAN THE VALUE SHOWN MAY CAUSE DAMAGE TO THE CRIMP TOOLING. REFER TO THE INSTRUCTION SHEET FOR PROPER SETUP AND ADJUSTMENTS.

**ATLANTIC VERSION**  
 Shown on sheets 1 of 4 & 2 of 4  
 (Pacific version shown on sheets 3 of 4 & 4 of 4)

LOC	DIST	REVISIONS					
A	66	P	LTN	DESCRIPTION	DATE	OWN	APVD
		H		ECR-17-006129	27APR2017	TB	GB
		J		ECR-18-003867	13MAR2018	LG	JD
		K		ECR-21-006763	07JUL2021	JWC	TE
		K1		ECR-21-007009	22JUL2021	JWC	TE

-	-	-	1	1	-	-	1803515-3	RAM ASSEMBLY, SF ATLANTIC	293
-	-	-	1	1	-	-	2-1803583-1	APPLICATOR BASIC ASSEMBLY, SF	292
-	2	2	2	2	2	2	2168083-1	SCR, SKT HD CAP, RoHS, M3 X 8.0	271
-	1	1	1	1	1	1	1-690438-0	FRONT STRIP GUIDE	270
-	1	-	1	-	1	-	2119641-1	FEED CAM, AIR FEED	248
-	1	1	1	1	1	1	2119082-4	CAM, SNAIL, INSULATION ADJUSTMENT	244
-	1	1	1	1	1	1	2079764-1	WASHER, WAVE SPRING, CREST-TO-CREST	243
-	1	1	1	1	1	1	2119083-1	RETAINER, INSULATION DIAL	242
-	1	1	1	1	1	1	7-18023-7	SCR, SKT HD CAP M3 X 4.0	241
-	-	1	-	1	-	1	2119580-1	MECHANICAL FEED ASSEMBLY	239
-	1	-	1	-	1	-	2844940-1	AIR FEED MODULE	238
-	-	-	1	1	-	-	4-1722335-3	STRIPPER, SIDE FEED	182
-	-	-	1	1	-	-	1-5018030-0	NUT, HEX, REG, RoHS, M3.5	181
-	-	-	1	1	-	-	1-1752354-9	STANDOFF, HOLD-DOWN	180
-	-	-	1	1	-	-	9931111-1	PIN, SLOTTED SPRING 3.0 X 20.0	177
-	-	-	1	1	-	-	5-22280-0	SPRING, COMPRESSION	176
-	-	-	1	1	-	-	1752353-3	GUIDE PIN, HOLDDOWN	175
-	-	-	1	1	-	-	1901680-2	GUIDE PIN, HOLDDOWN	174
-	REF	REF	REF	REF	REF	REF	994970-2	COUNTER, MAGNETIC	164
-	1	1	1	1	1	1	1-18028-2	WASHER, FLAT, REG M4	119
-	1	1	1	1	1	1	2844908-1	SCREW, LOCKING	99
-	1	1	1	1	1	1	2844907-1	POST, LOCKING	98
-	1	1	1	1	1	1	455888-4	SPACER, CRIMPER	82
-	1	1	1	1	1	1	1803607-3	DOCUMENTATION PACKAGE	71
-	1	1	1	1	1	1	2119791-6	DEPRESSOR, WIRE	70
-	1	1	1	1	1	1	2119740-1	TAG IDENTIFICATION	67
-	2	2	2	2	2	2	2168078-1	SCREW, DRIVE, RH, RoHS, 2 x .188	66
-	2	2	2	2	2	2	2-18032-5	SCR, SET, FLT PNT, M5 X 20.0	61
-	1	1	1	1	1	1	2168083-2	SCR, SKT HD CAP, RoHS, M4 X 8.0	60
-	1	1	1	1	1	1	5-18022-5	SCR, HEX HD CAP, M4 X 6.0	59
-	1	1	1	1	1	1	1338685-1	PAWL, FEED	56
-	4	4	4	4	4	4	2168083-3	SCR, SKT HD CAP, RoHS, M4 X 12.0	54
-	2	2	2	2	2	2	1-2168083-0	SCR, SKT HD CAP, RoHS, M4 X 10	53
-	1	1	1	1	1	1	5018030-1	NUT, HEX, REG, RoHS, M3	52
-	1	1	1	1	1	1	811242-5	BUMPER, HOLD DOWN	51
-	1	1	1	1	1	1	690753-2	SPACER, TONKER	50
-	1	2	1	2	1	2	18023-9	SCR, SKT HD CAP M4 X 6.0	49
-	-	1	-	1	-	1	2119652-1	FEED CAM, PRE FEED	48
-	-	1	-	1	-	1	2119653-1	FEED CAM, POST FEED	47
-	1	1	-	-	1	1	1803583-9	APPLICATOR BASIC ASSEMBLY, SF	46
-	1	1	-	-	1	1	1803515-1	RAM ASSEMBLY, SF ATLANTIC	44
-	1	1	1	1	1	1	1803602-1	SCR, BHSC, RoHS (M8 X 25)	41
-	1	1	1	1	1	1	1752356-3	SUPPORT, TERMINAL	34
-	2	2	2	2	2	2	2079383-5	SCR, BHSC, RoHS (M4 X 20)	33
-	2	2	2	2	2	2	2-2844962-8	SPACER, CYLINDRICAL, STRIP GUIDE	30
-	1	1	1	1	1	1	2844992-3	ASSEMBLY, STRIP GUIDE	29
-	2	2	2	2	2	2	22283-1	SPRING, COMPRESSION	27
-	1	1	1	1	1	1	356835-1	LEVER, DRAG RELEASE	26
-	1	1	1	1	1	1	240792-5	DRAG, TERMINAL	25
-	1	1	1	1	1	1	1320928-2	STRIP GUIDE	24
-	1	1	1	1	1	1	980371-4	SCR, SKT HD SHLDR 5.0 DIA X 6.0	23
-	1	1	-	-	1	1	2168083-2	SCR, SKT HD CAP, RoHS, M4 X 8.0	21
-	2	2	1	1	2	2	1-18028-2	WASHER, FLAT, REG M4	20
-	1	1	-	-	1	1	2119533-1	STRIPPER, SIDE FEED	19
-	1	1	1	1	1	1	2119806-1	INSERT, SHEAR	13
-	1	1	1	1	1	1	3-22280-3	SPRING, COMPRESSION	12
-	1	1	1	1	1	1	1-356885-4	STOP, SHEAR	11
-	1	1	1	1	1	1	2119805-1	SHEAR HOLDER, FRONT	10
-	1	1	1	1	1	1	1803095-3	FLOATING SHEAR, FRONT	9
1	2	2	1	1	1	1	1338692-1	ANVIL, COMBINATION .070	8
-	1	1	1	1	1	1	3-240641-8	SPACER	7
-	1	1	1	1	1	1	2119757-8	DEPRESSOR, SHEAR	5
-	1	1	1	1	1	1	2-238011-2	BLOCK, CRIMPER SPACER	4
1	2	2	1	1	1	1	1-2119582-0	CRIMPER, INSULATION F PREMIUM	3
-	1	1	1	1	1	1	455888-6	SPACER, CRIMPER	2
1	2	2	1	1	1	1	1-456404-8	CRIMPER, WIRE PREMIUM	1

ITEM NO	PART NO	DESCRIPTION	ITEM NO
-77	-72	-71	-52
-51	-2	-1	

DATE: 24AUG2011	CHK: L. ZHANG	DATE: 24AUG2011	CHK: L. ZHANG
DATE: 24AUG2011	CHK: S. XI	DATE: 24AUG2011	CHK: S. XI

TE Connectivity Harrisburg, PA 17105-3608	NAME: Ocean Side Feed Applicator
SIZE: A1	CAGE CODE: 00779
DRAWING NO: C=2151019	RESTRICTED TO: -
SCALE: 1:2	SHEET: 1 OF 4
REV: K1	

LOC	DIST	REVISIONS					
A	66	P	LYN	DESCRIPTION	DATE	DWN	APVD
		-		SEE SHEET 1			

# FEED TYPE MECHANICAL

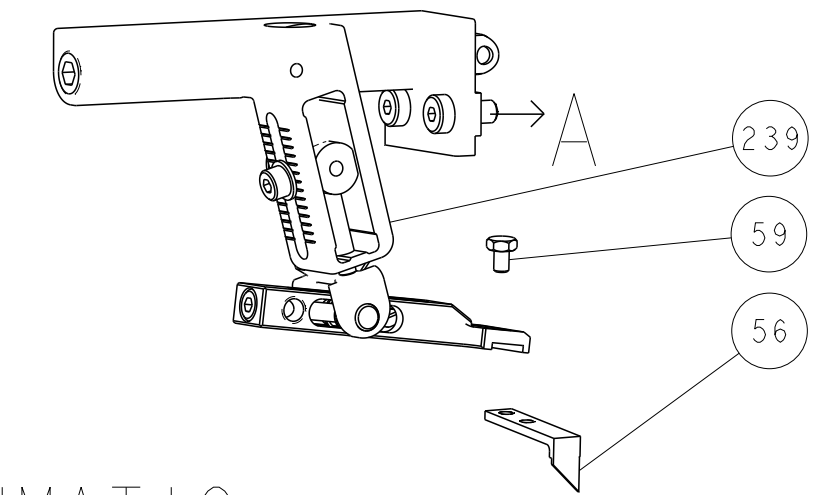

## PNEUMATIC

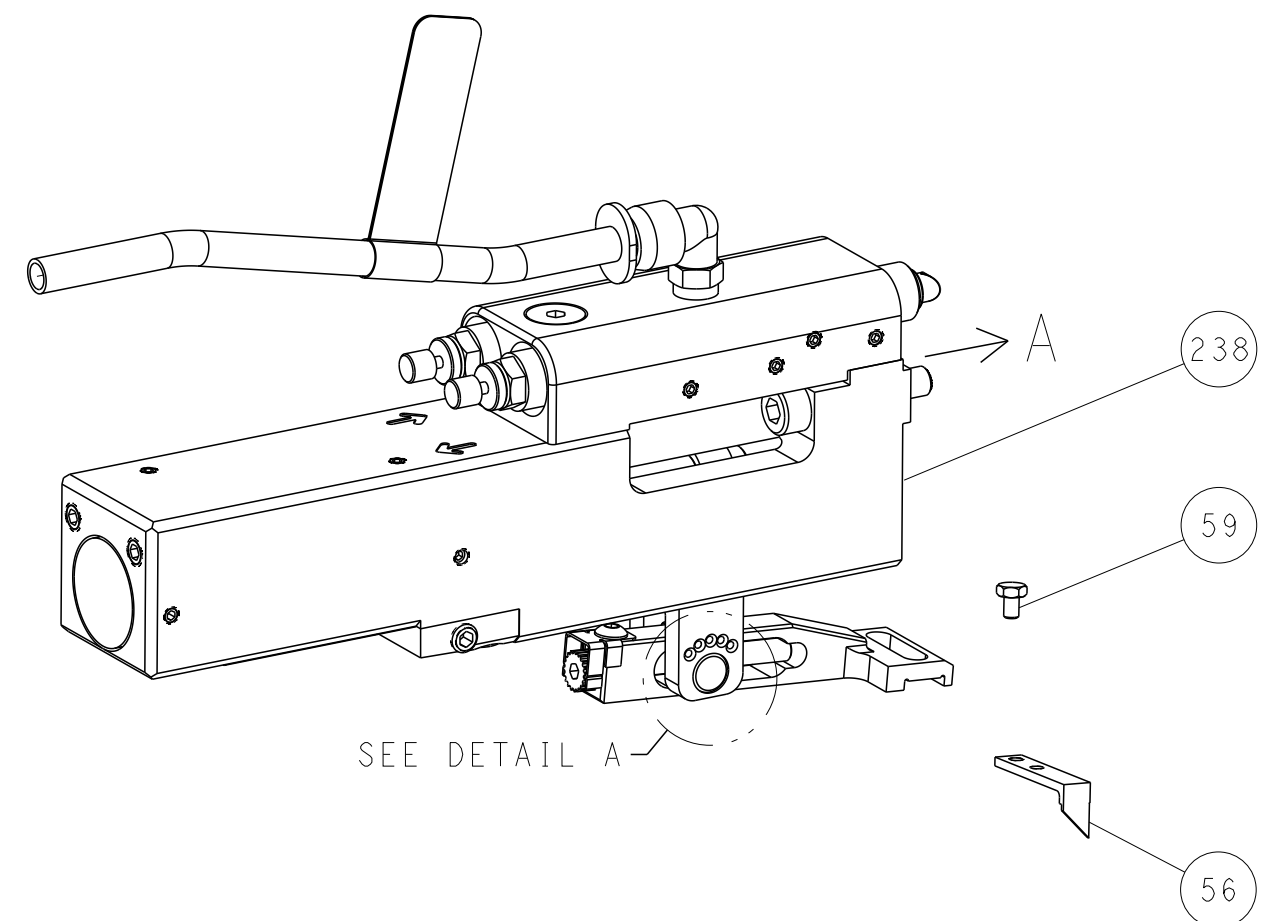

### FEED SPRING SETTING POSITION (SHOWN FROM REAR SIDE)

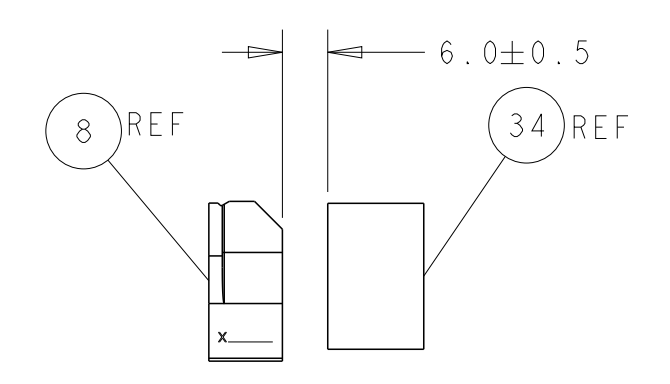
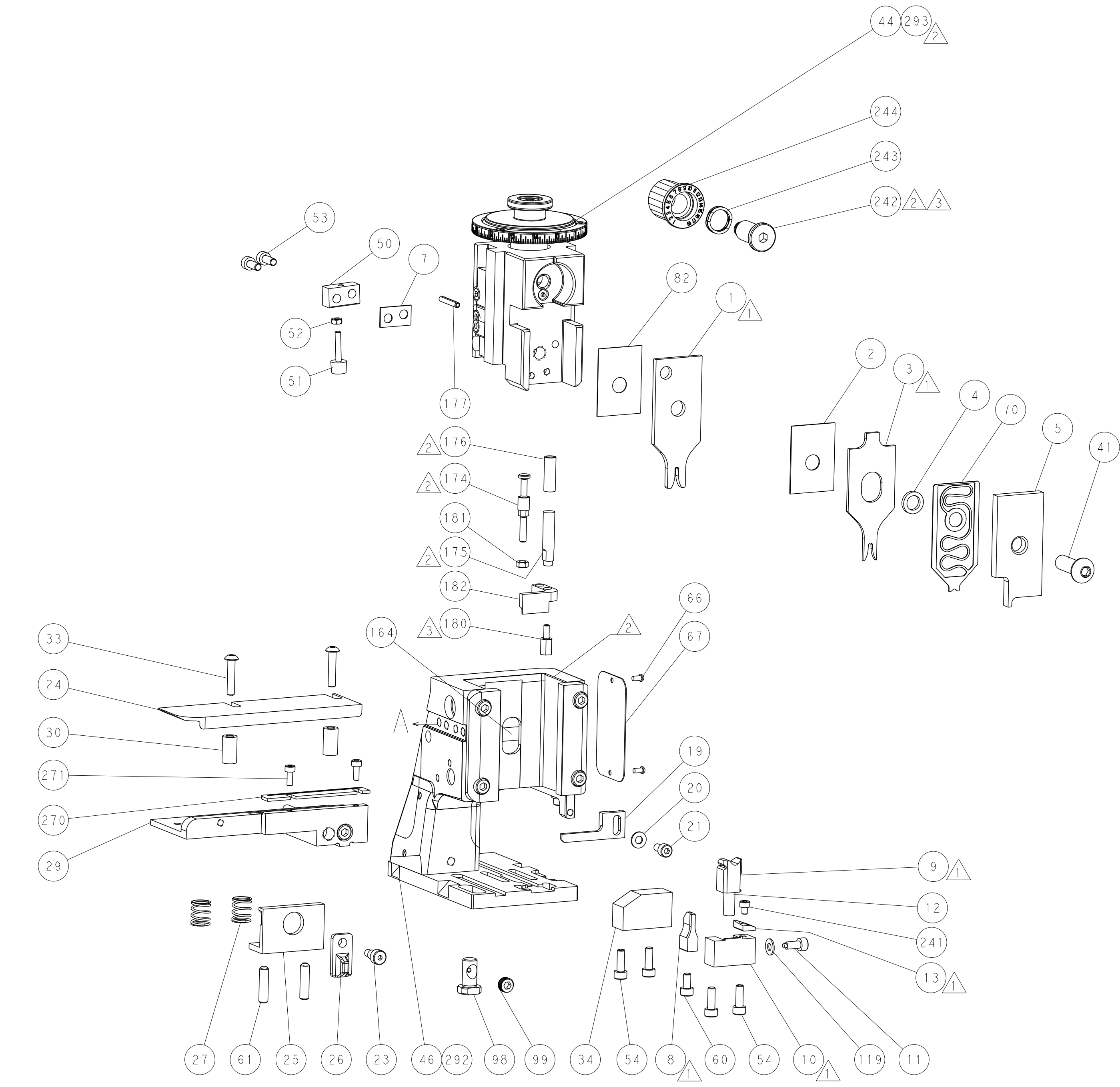
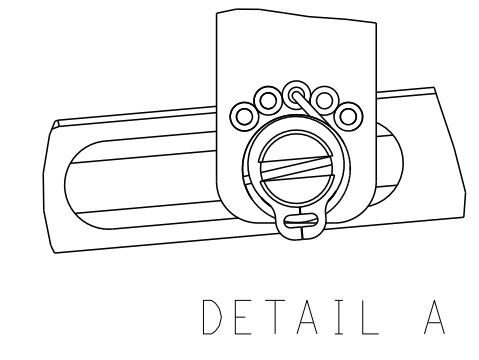

TERMINAL SUPPORT LOCATION

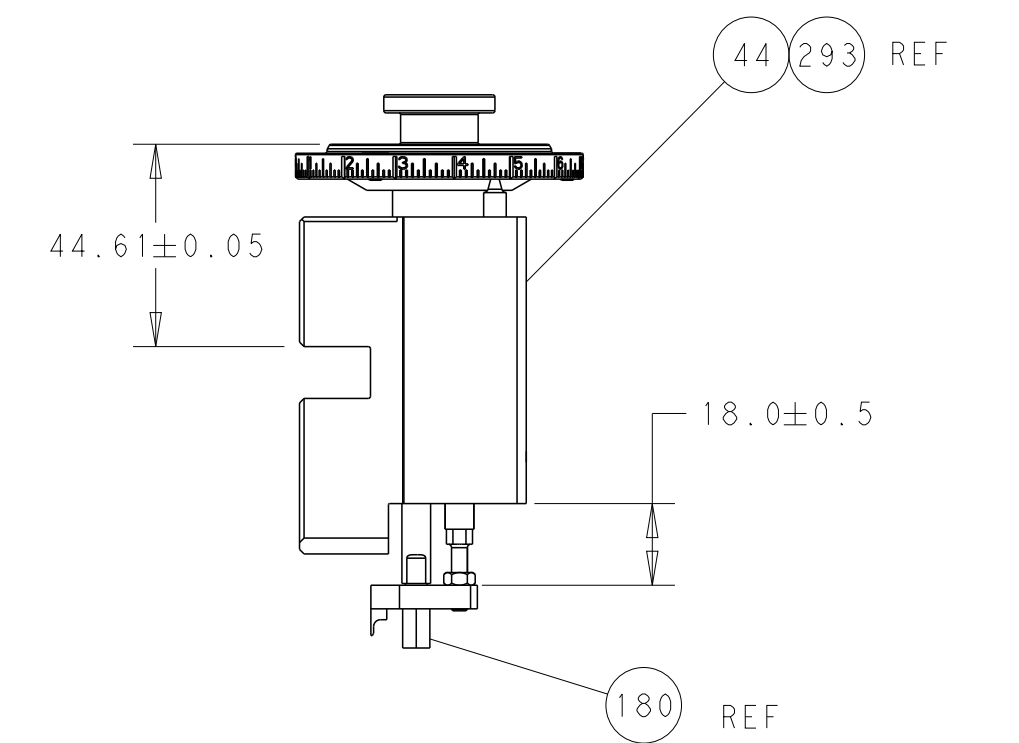

RAM & HOLD DOWN SET-UP

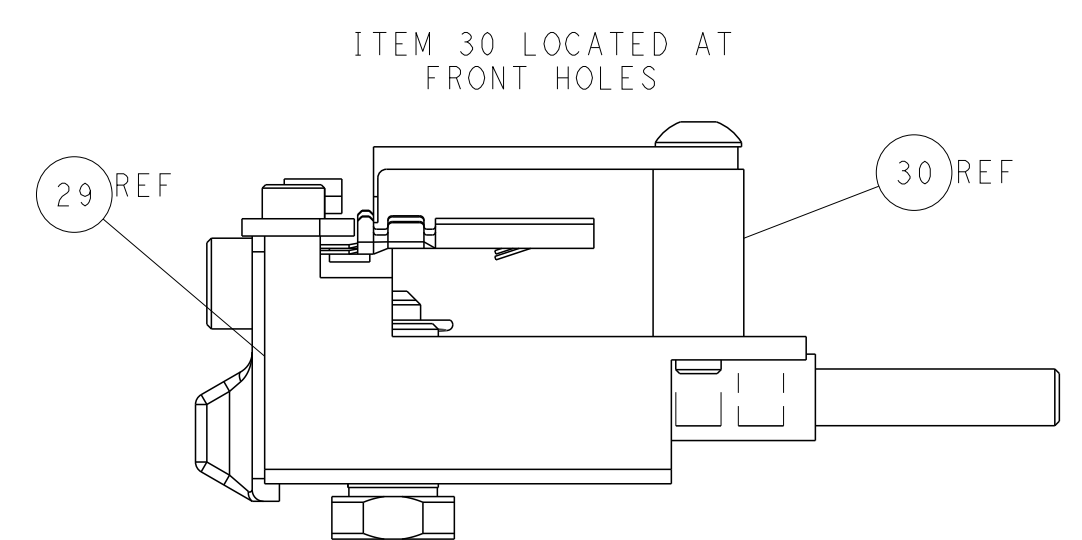

FEED TRACK POSITION GUIDE BY INSULATION BARREL

## CAM POSITIONS

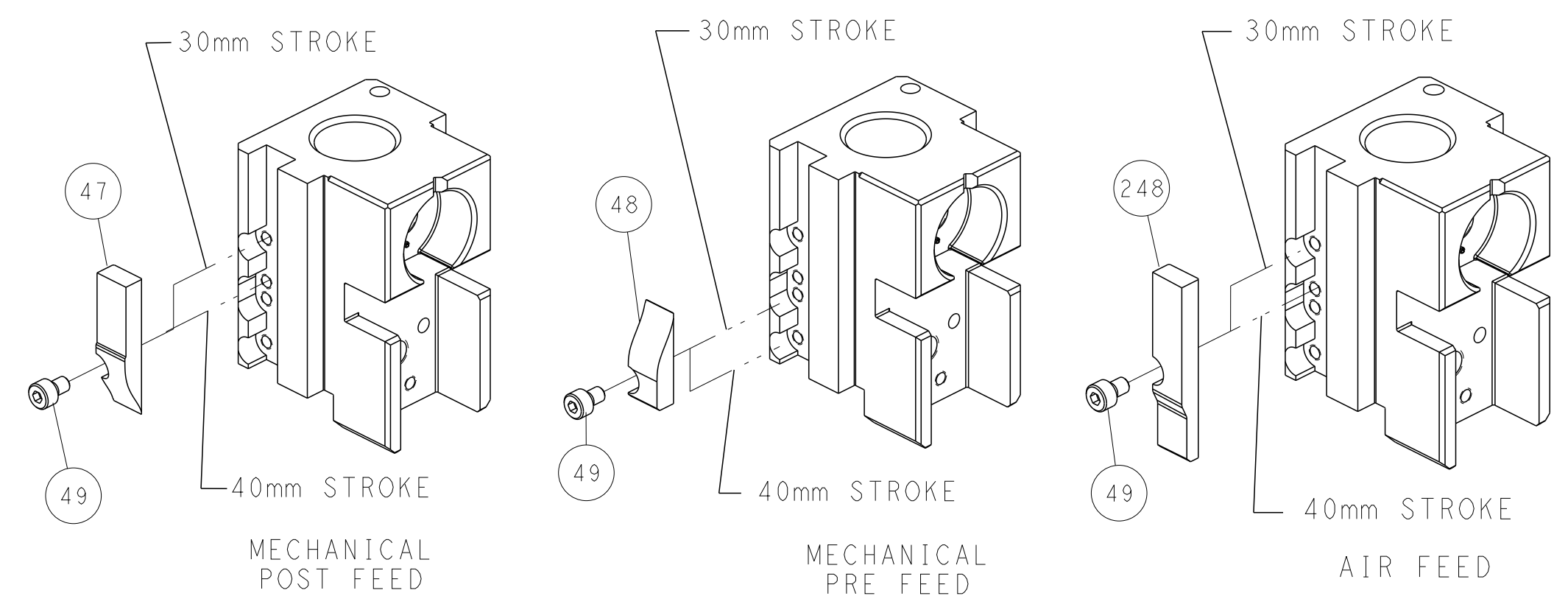

**ATLANTIC VERSION**  
 Shown on sheets 1 of 4 & 2 of 4  
 (Pacific version shown on sheets 3 of 4 & 4 of 4)

DIMENSIONS: mm TOLERANCES UNLESS OTHERWISE SPECIFIED: 0 PLC ± 1 PLC ± 2 PLC ± 3 PLC ± 4 PLC ± ANGLES FINISH		DWN L. ZHANG 24AUG2011 CHK L. ZHANG 24AUG2011 APVD S. XI 24AUG2011 PRODUCT SPEC APPLICATION SPEC WEIGHT Customer Accessible Production Drawing	NAME Ocean Side Feed Applicator SIZE CAGE CODE DRAWING NO. A1 00779 ©=2151019 SCALE 1:2 SHEET 2 OF 4 REV K1	TE Connectivity Harrisburg, PA 17105-3608
--	--	--	---	--

PART NUMBER	REVISION	DESCRIPTION	FEED TYPE
2-2151019-1	K	FINE CRIMP HEIGHT ADJUST	MECHANICAL
2-2151019-2	K	FINE CRIMP HEIGHT ADJUST	PNEUMATIC
7-2151019-7	E	CRIMP TOOLING KIT	-

PACIFIC VERSION TERMINATOR  
INTERFACE ADAPTER

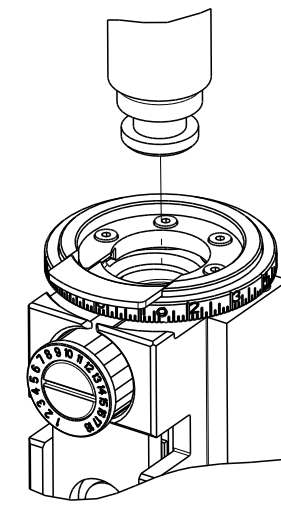

APPLICATOR DATA		
CRIMP	SIZE	TYPE
WIRE	1.78 mm [.070]	F
INSUL	2.54 mm [.100]	F

APPLICATOR INSTRUCTIONS  
408-35042

TERMINAL DATA: TE TERMINAL		TE CRIMP SPECIFICATION	
TERMINAL NAME: PIN/SOCKET, MATE-N-LOK			
WIRE STRIP LENGTH 3.96-4.75 mm [1.56-.187 IN]		INSULATION DIAMETER RANGE Ø1.02-2.54 mm [.040-.100 IN]	
TERMINAL APPLICATION SPECIFICATION (A)114-1010	(C)114-1012	(B)114-1011	-

TERMINALS APPLIED			
TE TERMINAL	TE TERMINAL	TE TERMINAL	TE TERMINAL
(C) 61115-1	(C) 61314-1	(B) 350560-1	(A) 350570-7
(C) 61116-1	(C) 61314-2	(B) 350561-1	(A) 350699-1
(C) 61116-2	(C) 61314-3	(B) 350561-2	(A) 350699-2
(C) 61116-3	(C) 61314-4	(B) 350561-3	(A) 350699-3
(C) 61116-4	(C) 61314-5	(B) 350561-5	(A) 350699-5
(C) 61116-5	(C) 61314-6	(B) 350561-7	(A) 350699-7
(C) 61116-6	(C) 61314-7	(B) 350561-8	(A) 350699-8
(C) 61116-7	(C) 61314-8	(A) 350570-1	(A) 350851-1
(C) 61116-8	(C) 61527-2	(A) 350570-2	(A) 350851-2
(C) 61116-9	(C) 170147-1	(A) 350570-3	(A) 350851-7
(C) 1-61116-3	(C) 170147-2	(A) 350570-6	

WIRE SIZE	CRIMP HEIGHT mm [INCH]	CRIMP HEIGHT REFERENCE SETTING
18 AWG	1.22+/-0.05 [.048+/-0.002]	6.1
20 AWG	1.09+/-0.05 [.043+/-0.002]	7.7
22 AWG	1.02+/-0.05 [.040+/-0.002]	8.4
24 AWG	0.96+/-0.05 [.038+/-0.002]	8.8

- 1 RECOMMENDED SPARE PARTS
  - 2 REFER TO SUPPLIED INSTRUCTION SHEET FOR CLEANING, LUBRICATION & STORAGE OF APPLICATOR.
  - 3 APPLY PART NUMBER 2-23419-6 LOCTITE TO THREADS OF ITEM 242.
  - 4 CRIMP HEIGHT REFERENCE SETTING WAS THE SETTING USED WHEN THE APPLICATOR WAS QUALIFIED AT THE FACTORY. ADJUSTMENT MAY BE NECESSARY WHEN RUNNING APPLICATOR IN THE FIELD.
5. LESS SPECIFIED OTHERWISE TORQUE VALUES SHALL BE USED PER DOCUMENT, 100-35000.

**\*WARNING**  
ON INSTALLATION, SET WIRE DISC TO CRIMP HEIGHT REFERENCE SETTING FOR LARGEST WIRE SIZE. CRIMP HEIGHT REFERENCE SETTINGS GREATER THAN THE VALUE SHOWN MAY CAUSE DAMAGE TO THE CRIMP TOOLING. REFER TO THE INSTRUCTION SHEET FOR PROPER SETUP AND ADJUSTMENTS.

PACIFIC VERSION  
Shown on sheets 3 of 4 & 4 of 4  
(Atlantic version shown on sheets 1 of 4 & 2 of 4)

LOC	DIST	REVISIONS					
A	66	P	LTN	DESCRIPTION	DATE	OWN	APVD
-	-	-	-	SEE SHEET 1	-	-	-

-	2	2	2168083-1	SCR, SKT HD CAP, RoHS, M3 X 8.0	271
-	1	1	1-690438-0	FRONT STRIP GUIDE	270
-	1	1	2119082-4	CAM, SNAIL, INSULATION ADJUSTMENT	244
-	1	1	2079764-1	WASHER, WAVE SPRING, CREST-TO-CREST	243
-	1	1	2119083-1	RETAINER, INSULATION DIAL	242
-	1	1	7-18023-7	SCR, SKT HD CAP M3 X 4.0	241
-	-	1	2119580-1	MECHANICAL FEED ASSEMBLY	239
-	1	-	2844940-1	AIR FEED MODULE	238
-	REF	REF	994970-2	COUNTER, MAGNETIC	164
-	1	-	2119641-2	FEED CAM, AIR FEED	151
-	1	1	2168083-8	SCR, SKT HD CAP, RoHS, M4 X 16	144
-	4	4	2168083-9	SCR, SKT HD CAP, RoHS, M4 X 20	143
-	-	1	2119653-2	FEED CAM, POST FEED	142
-	1	1	1-1803583-0	APPLICATOR BASIC ASSEMBLY, SF	141
-	1	1	1803516-1	RAM ASSEMBLY, SF PACIFIC	140
-	1	1	1-18028-2	WASHER, FLAT, REG M4	119
-	1	1	2844908-1	SCREW, LOCKING	99
-	1	1	2844907-1	POST, LOCKING	98
-	1	1	455888-4	SPACER, CRIMPER	82
-	1	1	1803607-3	DOCUMENTATION PACKAGE	71
-	1	1	2119791-6	DEPRESSOR, WIRE	70
-	1	1	2119740-1	TAG, IDENTIFICATION	67
-	2	2	2168078-1	SCREW, DRIVE, RH, RoHS, 2 x .188	66
-	2	2	2-18032-5	SCR, SET, FLT PNT, M5 X 20.0	61
-	1	1	5-18022-5	SCR, HEX HD CAP, M4 X 6.0	59
-	1	1	1338685-1	PAWL, FEED	56
-	2	2	1-2168083-0	SCR, SKT HD CAP, RoHS, M4 X 10	53
-	1	1	5018030-1	NUT, HEX, REG, RoHS, M3	52
-	1	1	811242-5	BUMPER, HOLD DOWN	51
-	1	1	690753-2	SPACER, TONKER	50
-	1	2	18023-9	SCR, SKT HD CAP M4 X 6.0	49
-	-	1	2119652-1	FEED CAM, PRE FEED	48
-	1	1	1803602-1	SCR, BHSC, RoHS (M8 X 25)	41
-	1	1	1752356-3	SUPPORT, TERMINAL	34
-	2	2	2079383-5	SCR, BHSC, RoHS (M4 X 20)	33
-	2	2	2-2844962-8	SPACER, CYLINDRICAL, STRIP GUIDE	30
-	1	1	2844992-3	ASSEMBLY, STRIP GUIDE	29
-	2	2	22283-1	SPRING, COMPRESSION	27
-	1	1	356835-1	LEVER, DRAG RELEASE	26
-	1	1	240792-5	DRAG, TERMINAL	25
-	1	1	1320928-2	STRIP GUIDE	24
-	1	1	980371-4	SCR, SKT HD SHLDR 5.0 DIA X 6.0	23
-	1	1	2168083-2	SCR, SKT HD CAP, RoHS, M4 X 8.0	21
-	1	1	1-18028-2	WASHER, FLAT, REG M4	20
-	1	1	2119533-1	STRIPPER, SIDE FEED	19
-	1	1	2119806-1	INSERT, SHEAR	13
-	1	1	3-22280-3	SPRING, COMPRESSION	12
-	1	1	1-356885-4	STOP, SHEAR	11
-	1	1	2119805-1	SHEAR HOLDER, FRONT	10
-	1	1	1803095-3	FLOATING SHEAR, FRONT	9
1	1	1	1338692-1	ANVIL, COMBINATION .070	8
-	1	1	3-240641-8	SPACER	7
-	1	1	2119757-8	DEPRESSOR, SHEAR	5
-	1	1	2-238011-2	BLOCK, CRIMPER SPACER	4
1	1	1	1-2119582-0	CRIMPER, INSULATION F PREMIUM	3
-	1	1	455888-6	SPACER, CRIMPER	2
1	1	1	1-456404-8	CRIMPER, WIRE PREMIUM	1

DIMENSIONS:		TOLERANCES UNLESS OTHERWISE SPECIFIED:		DRAWING NO		DESCRIPTION		ITEM NO	
mm	0 PLC ±	1 PLC ±	2 PLC ±	3 PLC ±	4 PLC ±	5 PLC ±	6 PLC ±	7 PLC ±	8 PLC ±
ANGLES	FINISH	WT	SCALE	SHEET	OF	REV			
				00779	2151019	3	4	K1	

LOC	DIST	REVISIONS					
A	66	P	LTN	DESCRIPTION	DATE	OWN	APVD
-	-	-	-	SEE SHEET 1	-	-	-

# FEED TYPE MECHANICAL

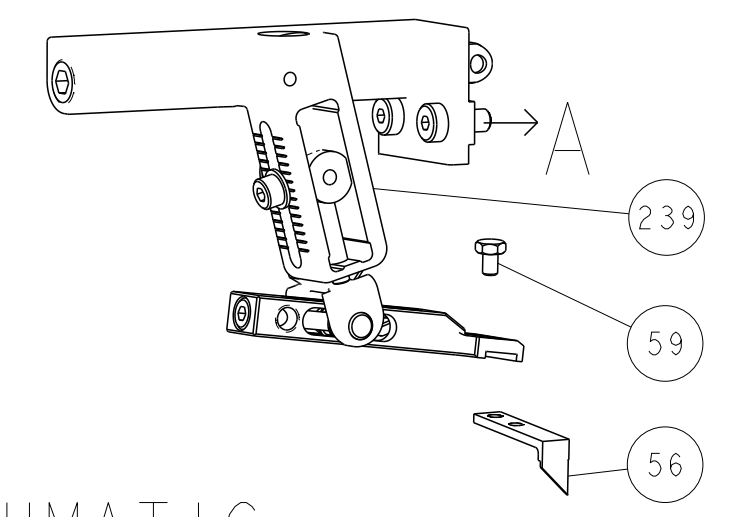

## PNEUMATIC

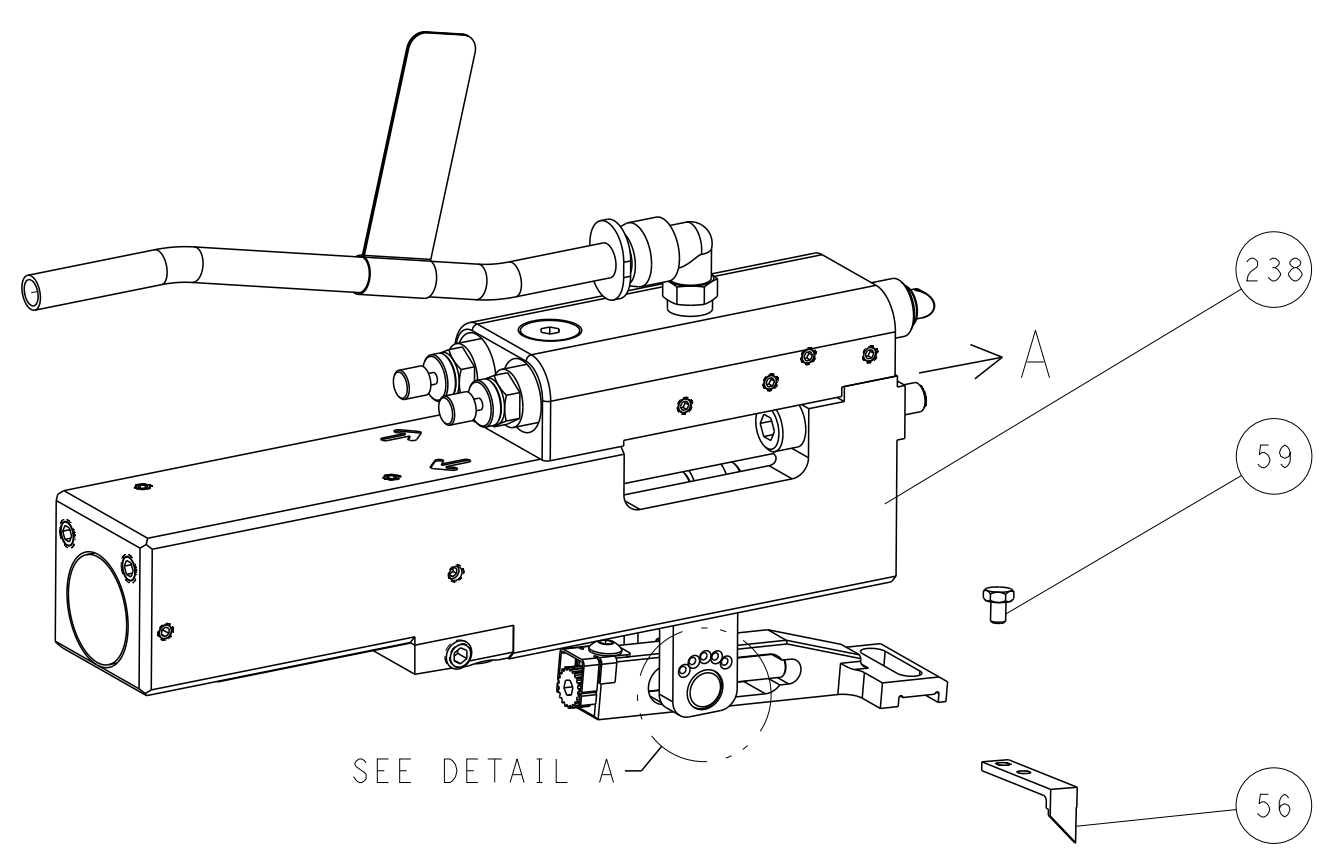

### FEED SPRING SETTING POSITION (SHOWN FROM REAR SIDE)

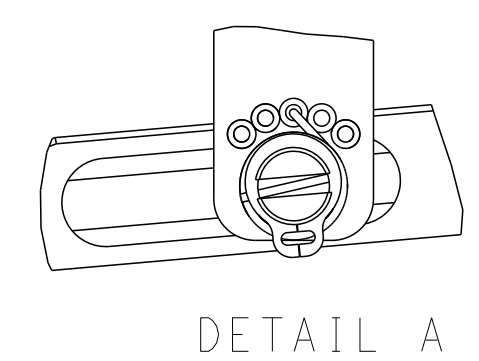

DETAIL A

## CAM POSITIONS

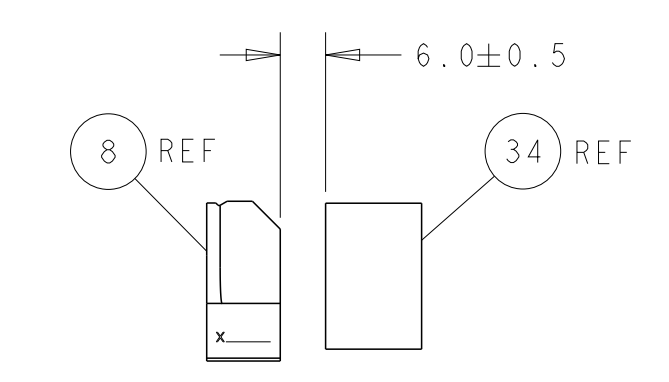
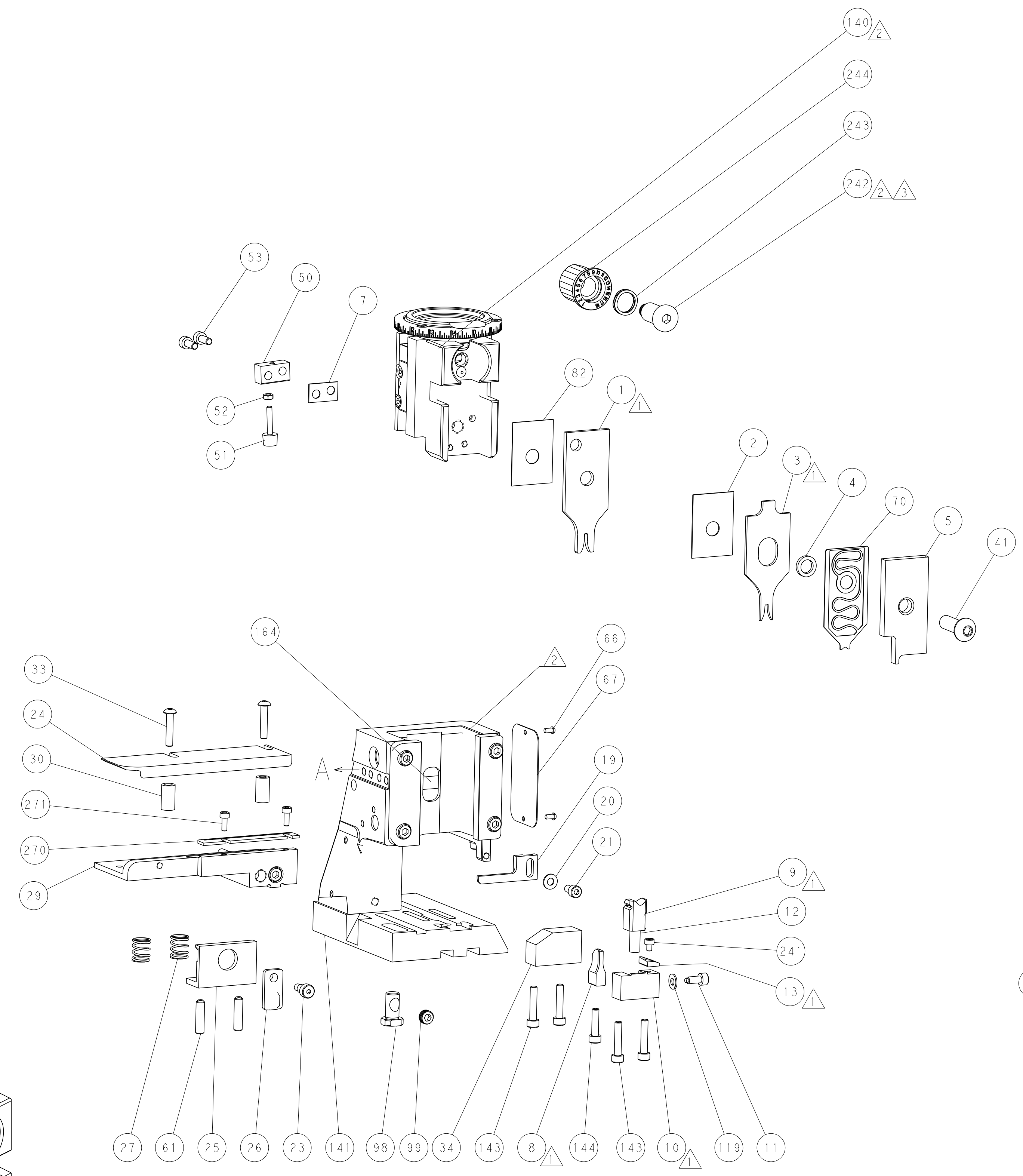
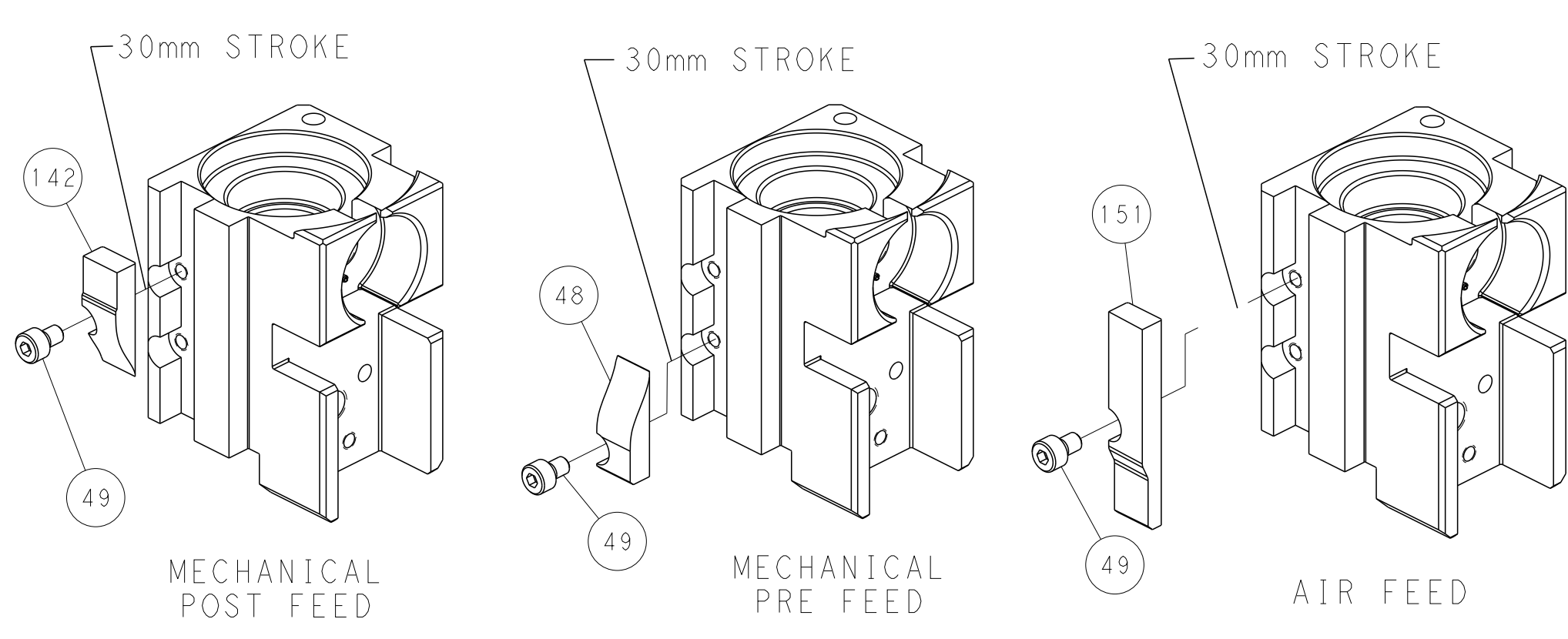

TERMINAL SUPPORT LOCATION

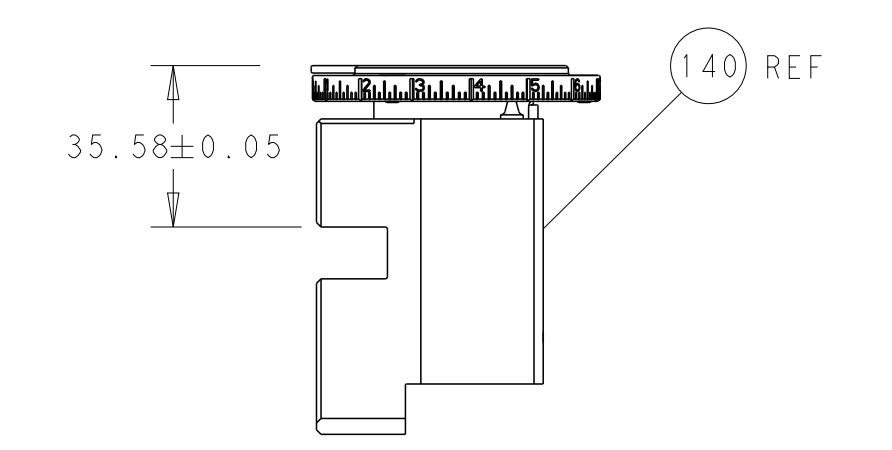

RAM SET-UP

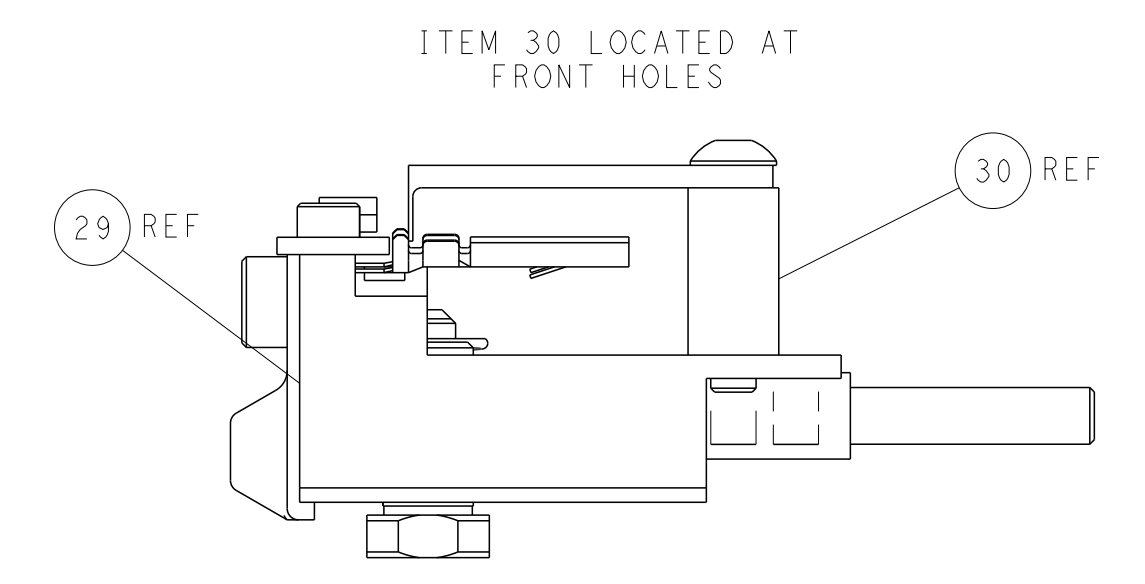

FEED TRACK POSITION  
GUIDE BY INSULATION BARREL

**PACIFIC VERSION**  
 Shown on sheets 3 of 4 & 4 of 4  
 (Atlantic version shown on sheets 1 of 4 & 2 of 4)

<small>THIS DRAWING IS UNPUBLISHED. RELEASED FOR PUBLICATION. ALL RIGHTS RESERVED. THIS DRAWING IS CONTROLLED DOCUMENT FOR THE ELECTRONICS CORPORATION. IT IS THE PROPERTY OF THE CORPORATION AND IS NOT TO BE REPRODUCED OR TRANSMITTED IN ANY FORM OR BY ANY MEANS, ELECTRONIC OR MECHANICAL, INCLUDING PHOTOCOPYING, RECORDING, OR BY ANY INFORMATION STORAGE AND RETRIEVAL SYSTEM, WITHOUT THE WRITTEN PERMISSION OF THE CORPORATION.</small>		DWN L. ZHANG 24AUG2011 CHK L. ZHANG 24AUG2011 S. XI 24AUG2011 APVD S. XI 24AUG2011	NAME Ocean Side Feed Applicator
DIMENSIONS: mm 	TOLERANCES UNLESS OTHERWISE SPECIFIED: 0 PLC ± 1 PLC ± 2 PLC ± 3 PLC ± 4 PLC ± ANGLES ± FINISH	SIZE A1 CAGE CODE 00779 DRAWING NO C=2151019	RESTRICTED TO -
MATERIAL		WEIGHT - SCALE 1:2 SHEET 4 OF 4 REV K1	CUSTOMER ACCESSIBLE PRODUCTION DRAWING