

1. Mechanical Dimensions:

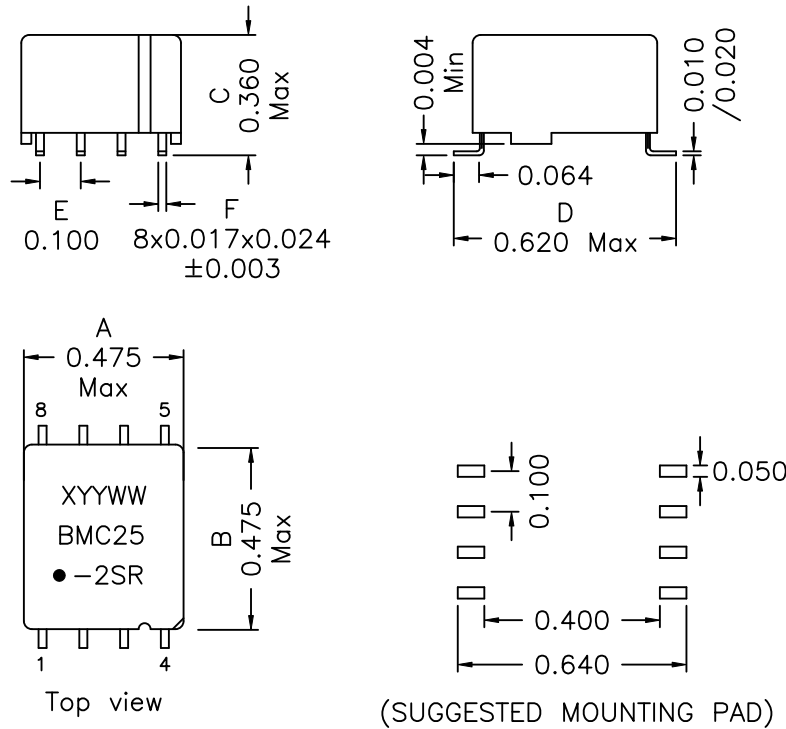

2. Schematic:

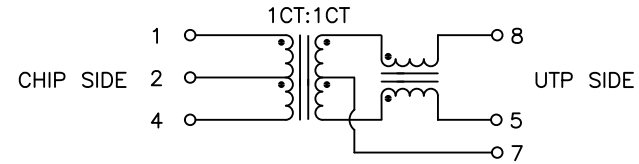

3. Electrical Specifications: @25°C

UTP Impedance: 100 OHMS
 Turns Ratio: (CHIP : UTP)=1CT:1CT±2%
 Isolation Voltage: 2500Vrms, CHIP SIDE to UTP SIDE
 UTP Side OCL: 350uH Min @100KHz 0.1V, 8mAdc
 UTP Side Q: 5 Min @100KHz 0.1V,
 Rise Time (10-90%): 4.0ns Typical
 Insertion Loss (1-100MHz): -1.0dB Maximum
 Return Loss: 30MHz 60MHz 80MHz
 -20dB -14dB -11.5dB Typ
 CMRR: 30MHz 50MHz 100MHz
 -42dB -37dB -33dB Typ

Notes:

1. Solderability: Leads shall meet MIL-STD-202G, Method 208H for solderability.
2. Flammability: UL94V-0
3. ASTM oxygen index: > 28%
4. Insulation System: Class F 155°C. UL file E151556
5. Operating Temperature Range: -40°C to +125°C
6. Storage Temperature Range: -55°C to +125°C
7. Aqueous wash compatible
8. SMD Lead Coplanarity: ±0.004"(0.102mm)
9. Electrical and mechanical specifications 100% tested
10. RoHS Compliant Component
11. Recommended IR Reflow peak temp of 235°C Max.

DOC. REV: A/1

XFMRs [®] www.XFMRs.com	Title: TRANSFORMER		
	UNLESS OTHERWISE SPECIFIED	P/N: XFBMC25-2SR-A	REV. A
TOLERANCES: .xxx ±0.010	DWN.	Yu	Aug-06-20
Dimensions in Inch	CHK.	YK Liao	Aug-06-20
SHEET 1 OF 1	APP.	DDC	Aug-06-20

CONCEPT

GENERAL INFORMATION

Part Number:	95-N08P-GP02-YK
Part Description:	8pin open bottom Lpin case
Weight (lbs.):	0.00330 lbs.approx
T&R Notes:	1) PROCESS IN ACCORDANCE WITH EIA-461-2 STANDARDS * TAPE LEADER DIMENSION 15.30" MIN. * TAPE TRAILER DIMENSION 6.30" MIN. 2) PARTS SHOULD BE PACKAGED IN ACCORDANCE WITH ESD GUIDELINES IN EIA-541. 3) REEL LABEL: 'A' * PART NUMBER * QUANTITY * DATE CODE

SUPPLIER INFORMATION

Company Name:	XFMRS
Address Line 1:	UNIT G-J, 3/F, BLK 1, GOLDEN DRAGON IND CTR
State / ZIP:	152-160 TAI LIN PAI ROAD
Country:	HONG KONG, CHINA
Program Manager:	Kitty Lai
Contact E-mail:	kilai@xfmrs.com.hk
Contact Phone:	852 2423 1689

PRIMARY PACKAGING

Packaging Type:	PST&R			
Dimensions(cm):	L 33.0	W 33.0	H 3.2	
Weight:	1.08 lbs. approx			
QPC (Parts Per Reel)	250 pcs.			
Total Weight w/parts:	1.90 lbs.			
Banding / Shrink / Wrap:	BOPP Wrap			
Other:	N/A			

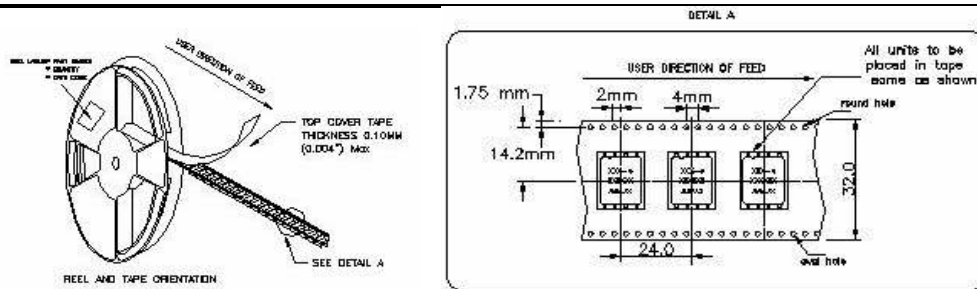

SECONDARY PACKAGING

Packaging Type:	Paper Box			
Dimensions(cm):	L 36.5	W 36.5	H 24.0	
Weight:	1.89 lbs.			
Boxes per Unit Load:	2000 pcs.			
Total weight w/Parts (lbs):	17.62 lbs.approx			
Banding / Shrink / Wrap:	BOPP Wrap / PP Banding			
Other:	N/A			

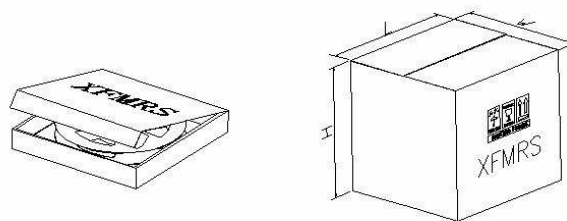

SHIPPING INFORMATION

Packaging Type:	PE Pallet			
Unit Load dims(cm):	L 120	W 100	H 113	
Weight:	16.72 lbs.			
Number of box Loads:	24 box.			
Number of Parts:	48000 pcs.			
Load weight total (lbs):	439.50 lbs.approx			
Banding / Shrink / Wrap:	PE Shrink			

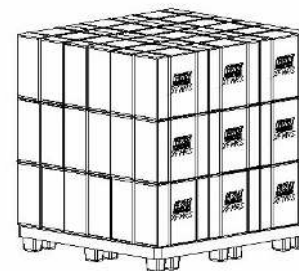

PACKAGING APPROVAL

Internal Document
 Manufacture / Q.A ./ Process Instructions

Drafted	Checked	Approved	Rev	Date
Kong	Liao		A/1	Aug-07-20

XFMRs

Recommended Infrared Reflow Temperature Profile for RoHS Compliant Parts

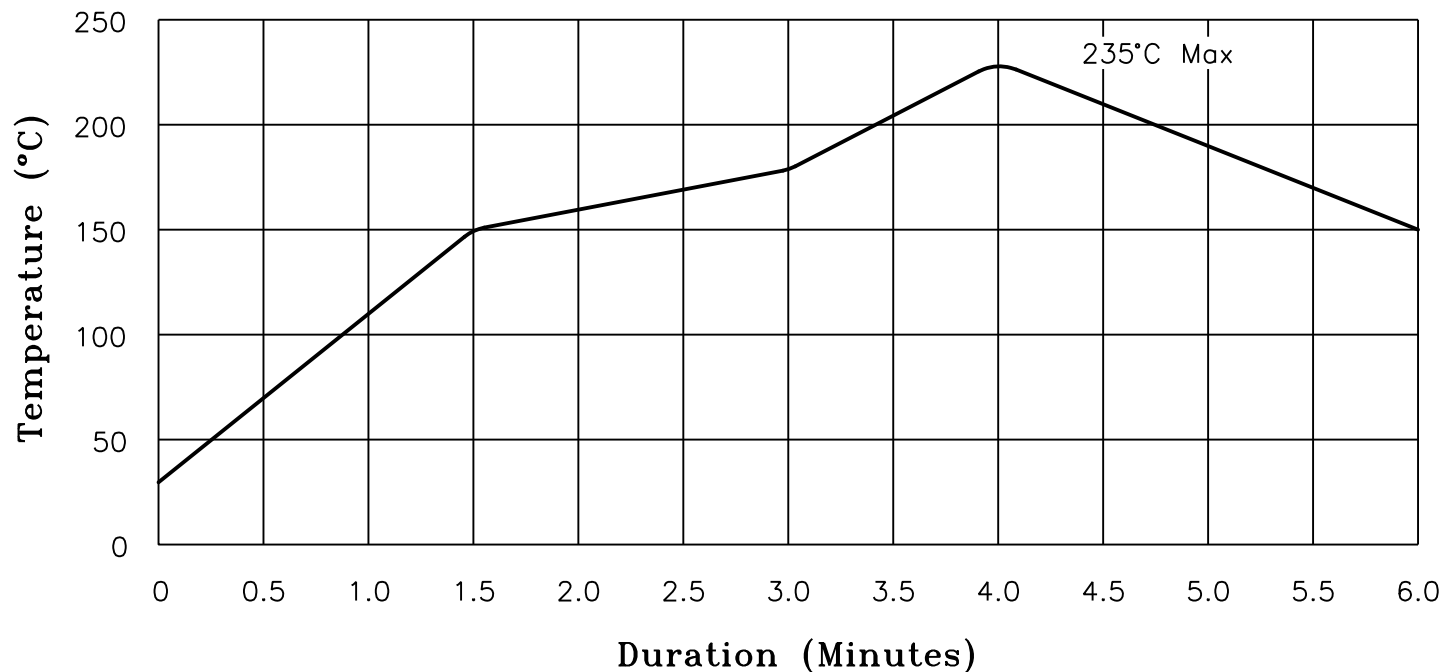

NOTES: Maximum duration at 235+0/-5° shall be 10-15 seconds.
 Maximum duration above 217° shall be 45-75 seconds.
 ALL Temperatures refer to topside of the package, measured on the package body surface.
 *Excludes ALL RJ-45 Combo products. (See IR Reflow for Non-RoHS Compliant parts)

XFMRs Inc www.XFMRs.com	Title: IR REFLOW CHART (RoHS Compliant parts)			
	UNLESS OTHERWISE SPECIFIED TOLERANCES: N/A	P/N: N/A	REV. A	
	DWN.	廖玉坤	Aug-18-05	
	CHK.	李清儿	Aug-18-05	
SHEET 1 OF 1	APP.	Isaiah M	Aug-18-05	