



Datasheet

(DOC No. XXXXXXXXX)

» HX5330 LC Lens Driver

Version 2.0 March 2021



Datasheet

HX5330

LC Lens Driver

Overview:

The HX5330 is three channels LC Lens driver containing a step-up converter which provides for programmable output voltages to drive the LC Lens with a sufficient voltage. The HX5330 can be operated with 6-bit resolution D/A converter for setting the driver operating voltage up to 15V.



Revision History

Revision	Date	Revision Description	Originator(s)
Version 1.0	09/29/2020	Initial release.	CC Chen
Version 1.1	10/06/2020	Modify title font size and remove table.	CC Chen
Version 1.2	01/25/2021	All updated.	CC Chen
Version 2.0	03/23/2021	All updated for public version.	CC Chen



Table of Contents

1. General Description	7
2. Features	7
3. Applications	7
4. Simplified Application Diagram	7
5. Function Block Diagram	8
6. Pin Assignment	8
7. Pin Description	9
8. DC Characteristics	10
8.1 Absolute maximum rating	10
8.2 Recommended operating rating	10
9. Electrical Characteristics	11
9.1 DC/DC converter	11
9.2 LC diffuser driver	11
9.3 I ² C interface	13
10. Function Description	15
10.1 Digital to analog converter (DAC)	15
10.2 I ² C protocol	15
10.2.1 I ² C protocol definition	16
10.2.2 I ² C slave address	16
10.2.2 Write-mode	16
10.2.3 Read-mode	17
10.3 I ² C command list and description	17
10.3.1 Write protect register address: 0x00h (Default value)	17
10.3.2 Control register address: 0x01h (Default value)	17
10.3.3 Safety detection status: 0x00h (Default value)	19
10.3.4 Heater and Output voltage: 0x3Fh (Default value)	19
10.3.5 Output AC frequency: 0x13h (Default value)	20
10.3.6 Over drive voltage: 0x40h (Default value)	20
11. Application Information	22
11.1 Operation flow chart	22
11.2 Safety Detection Function	22
11.3 Over Drive Function	23
11.4 Application Reference Circuit	23
11.5 Power Sequence	24



11.6 External Power	25
12. Package Outline Dimension	26
13. Ordering Information	26
14. Remarks.....	26



List of Figures

Figure 1 Simplified application diagram	7
Figure 2 Function block diagram	8
Figure 3 Bottom view	8
Figure 4 I ² C serial-interface timing diagram	14
Figure 5 I ² C Signal Timing	15
Figure 6 I ² C Start/Stop	15
Figure 7 I ² C Data Transfer	16
Figure 8 I ² C command list and description	17
Figure 9 LC_EN, Spot_EN, LCCOUT_EN, LCCPIN_EN, LCBPIN_DS functions	18
Figure 11 Operation flow chart	22
Figure 12 Safety detection function operation	22
Figure 13 Over drive function operation	23
Figure 14 Application circuit (For Load Capacitance < 2uF)	23
Figure 15 Application circuit (External 15V power)	24
Figure 16 Power sequence	24
Figure 17 Simplified application diagram with LC Lens RC model	25
Figure 18 Package Outline Dimension	26



List of Tables

Table 1 Slave Address Table 16



1. General Description

The HX5330 is three channels LC Lens driver containing a step-up converter which provides for programmable output voltages to drive the LC Lens with a sufficient voltage. The HX5330 can be operated with 6-bit resolution D/A converter for setting the driver operating voltage up to 15V.

2. Features

- VIN input supply voltage range: 2.5V to 3.3V
- Output voltage Maximum is 15V
- Support 6-bit DAC (Digital to Analog Converter)
- 3 channels drivers output for LC diffuser
- Support absence of LC Lens detection (Safety detection)
- Support I²C programmable
- Support GPIO controls output voltage
- Support 8-bit programmable AC output frequency (12.8kHz ~ 50Hz)
- 14-pin WLCSP 1.035mm x 2.035 x 0.535mm package

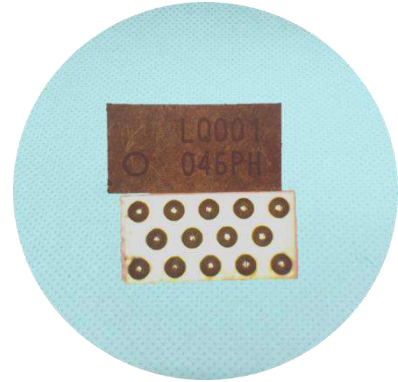

3. Applications

- LC Lens
- Structured-light 3D illuminations

4. Simplified Application Diagram

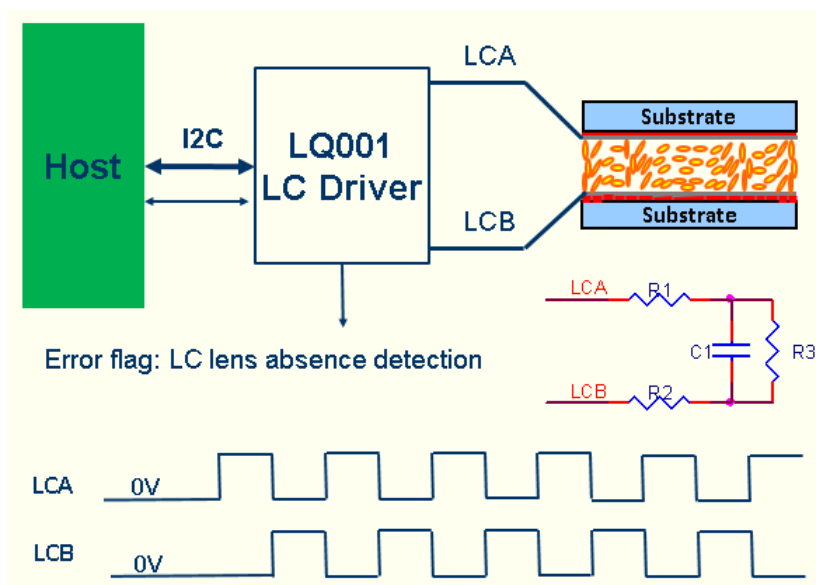

Figure 1 Simplified application diagram



5. Function Block Diagram

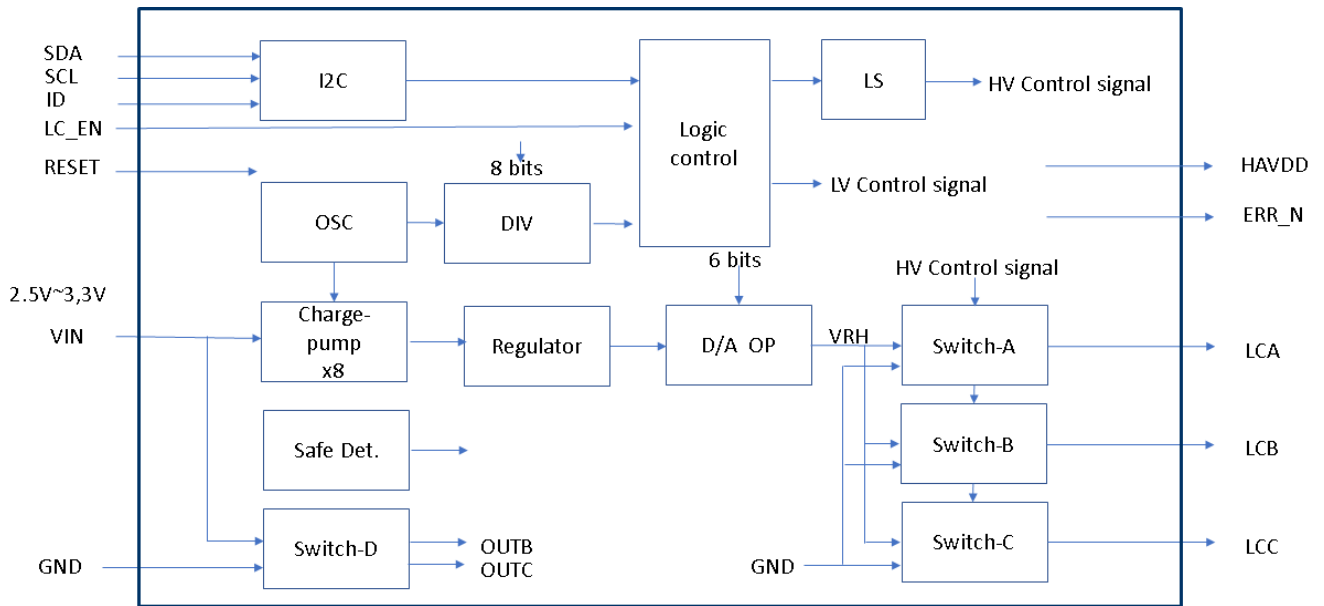

Figure 2 Function block diagram

6. Pin Assignment

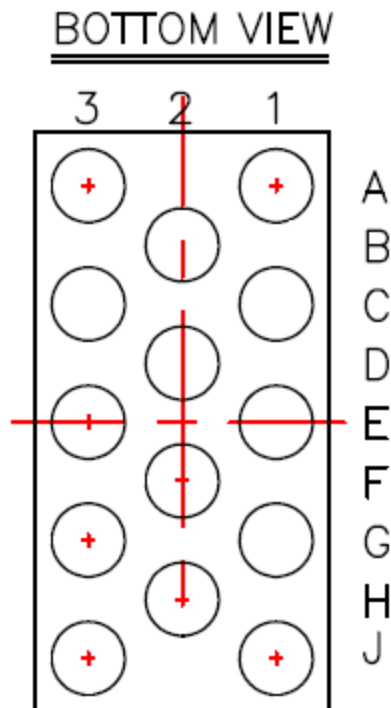

Figure 3 Bottom view



7. Pin Description

P: power pin, G: Ground pin, I: Input pin, O: Output pin, I/O: Inout pin

Pin	Type	Pin name	Description
A1	O	ERR_N	Safety detection flag, Open drain pin, Low is error
C1	I	LC_EN	LC Lens output enable
E1	I	RESET	Reset signal. This pin low for at last 15us
G1	I/O	SDA	I ² C compatible serial data input / output.
J1	I	SCL	I ² C compatible serial clock input.
B2	G	AGND	Analog Power ground
D2	G	AGND	Analog Power ground
F2	G	DGND	Digital Power ground
H2	I	ID	I ² C ID definition (ID=L, I ² C ID=0x74, ID=H I ² C ID=0x75)
A3	P	VIN	Power supply input pin for all the control circuits and step up converter.
C3	P	HAVDD	Step up converter output pin or external power supply.
E3	O	LCA	LC Lens output and safety detection
G3	O	LCB	LC Lens output and safety detection
J3	O	LCC	LC Lens output



8. DC Characteristics

8.1 Absolute maximum rating

Parameter		Spec.			Unit
		Min.	Typ.	Max.	
VIN, SDA, SCL, RESET, LC_EN, ERR_N, ID		-0.3	-	3.6	V
HAVDD to GND		-0.3	-	18	V
LCA, LCB, LCC to GND		-0.3	-	18	V
ESD susceptibility	HBM (Human Body Mode) ⁽¹⁾	2	-	-	KV
	MM (Machine Mode) ⁽²⁾	200	-	-	V
Storage temperature range		-40	-	125	°C
Lead temperature (soldering, 10 sec)		-	-	260	°C

Note: (1) HBM follow test standard: MIL-STD-883C Method 3015.7.

(2) MM follow test standard: EIAJ-IC-121 Method 20.

8.2 Recommended operating rating

VIN=3.3V, GND=0, TA=25°C, unless otherwise noted.

Parameter	Symbol	Spec.			Unit
		Min.	Typ.	Max.	
Supply Voltage	VIN	2.5		3.3	V
High Voltage Storage Capacitor	CHAVDD		1		μF
Load (Lens) Capacitance	CLOAD		200		pF
Output Frequency	FOUT		1		KHz
Operating temperature range	TA	-20	-	85	°C



9. Electrical Characteristics

(VIN=3.3V, GND=0V, TA=25°C, unless otherwise noted.)

Parameter	Condition	Spec.			Unit
		Min.	Typ.	Max.	
VIN quiescent current	no loading	-	2	-	mA
VIN shutdown current	RESET=GND	-	50	-	μA
VIN sleep current	SLEEP_EN="H"	-	500	-	μA
Input logic high voltage	V _{IH}	1.4	-	-	V
Input logic low voltage	V _{IL}	-	-	0.4	V
Output logic low voltage	V _{OL} , R _{pull-H} =4.7KΩ	-	-	0.3	V

9.1 DC/DC converter

(VIN=3.3V, GND=0V, TA=25°C, unless otherwise noted.)

Parameter	Condition	Spec.			Unit
		Min.	Typ.	Max.	
HAVDD Output voltage	VIN=3.3V, C _{HAVDD} =1uF	0	-	18	V
HAVDD startup time	VIN=3.3V, C _{HAVDD} =1uF, HAVDD=18V, no load	-	10	-	mS
Switching frequency range	Normal mode	-	1.6	-	MHz
Switching frequency range	Sleep mode	-	80	-	KHz

9.2 LC diffuser driver

(VIN=3.3V, GND=0V, TA=25°C, unless otherwise noted.)

Parameter	Condition	Spec.			Unit
		Min.	Typ.	Max.	
Output voltage swing high (V _{max})	LC_EN=H & 0x01h = 0x01h	-	-	15	V
Output voltage swing low	LC_EN=L 0x01h = 0x00h	0	-	-	V
Output voltage accuracy	VAP[5:0]=0x3Fh	-10	-	+10	%
Output current (*1)	HAVDD=15V, VAP[5:0]=0x3Fh LCA/B/C Output -0.5V	-	-	400	μA



Parameter	Condition	Spec.			Unit
		Min.	Typ.	Max.	
	HAVDD=15V, VAP[5:0]=0x3Fh LCA/B/C Output +0.5V	400	-	-	μA
	HAVDD=15V, VAP[5:0]=0x19h LCA/B/C Output -0.25V	-	-	400	μA
	HAVDD=15V, VAP[5:0]=0x19h LCA/B/C Output +0.25V	400	-	-	μA
Output voltage resolution		-	6	-	Bits
Diffuser driver frequency range		0.05	1	12.8	KHz
Diffuser driver frequency resolution		-	8	-	Bits
Diffuser driver on duty		45	50	55	%
Rising Slew rate (SR) (*2)	LC_EN=H & 0x01h = 0x01h, VAP[5:0] = 0x3Fh Loading capacitor = 470pF	-	5.2	-	V/μS
Rising Slew rate (SR) (*2)	LC_EN=H & 0x01h = 0x01h, VAP[5:0] = 0x3Fh Loading capacitor = 470pF Resistor (R1, R2) = 1KΩ	-	0.35	-	V/uS

Note 1: External HAVDD=15V

Note 2: Loading capacitor (C1) = 470pF, R3 is over few MΩ

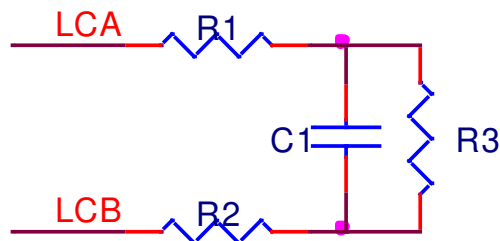



9.3 I²C interface

(VIN=3.3V, GND=0, TA=25°C, unless otherwise noted.)

Parameter	Symbol	Condition	Spec.			Unit
			Min.	Typ.	Max.	
I²C timing characteristics						
Low level input voltage	V _{IL}	VIN=2.5V~3.3V	-	-	0.4	V
High level input voltage	V _{IH}	VIN=2.5V~3.3V	1.4	-	-	V
Serial-clock frequency	F _{SCL}	-	1	-	1000	KHz
Bus free time between STOP and START conditions	T _{BUF}	F _{SCL} =1000KHz	0.4	-	-	μs
		F _{SCL} =400KHz	1.3	-	-	μs
Hold time (Repeated) START condition	T _{HD_STA}	F _{SCL} =1000KHz	0.4	-	-	μs
		F _{SCL} =400KHz	0.6	-	-	μs
SCL pulse-width low	T _{LOW}	F _{SCL} =1000KHz	0.4	-	-	μs
		F _{SCL} =400KHz	1.3	-	-	μs
SCL pulse-width high	T _{HIGH}	F _{SCL} =1000KHz	0.4	-	-	μs
		F _{SCL} =400KHz	0.6	-	-	μs
Setup time for a repeated START condition	T _{SU_STA}	F _{SCL} =1000KHz	0.4	-	-	μs
		F _{SCL} =400KHz	0.6	-	-	μs
Data hold time	T _{HD_DAT}	F _{SCL} =1000KHz	0	-	500	ns
		F _{SCL} =400KHz	0	-	900	ns
Data setup time	T _{SU_DAT}	F _{SCL} =1000KHz	100	-	-	ns
		F _{SCL} =400KHz	100	-	-	ns
SDA and SCL receiving rise time	T _R	F _{SCL} =1000KHz	20+0.1CB ^(*1)	-	100	ns
		F _{SCL} =400KHz	20+0.1CB ^(*1)	-	300	ns
SDA and SCL receiving fall time	T _F	F _{SCL} =1000KHz	20+0.1CB ^(*1)	-	100	ns
		F _{SCL} =400KHz	20+0.1CB ^(*1)	-	300	ns
SDA transmitting fall time	T _F	F _{SCL} =1000KHz	20+0.1CB ^(*1)	-	100	ns
		F _{SCL} =400KHz	20+0.1CB ^(*1)	-	300	ns
Setup time for STOP condition	T _{SU_STO}	F _{SCL} =1000KHz	0.4	-	-	μs
		F _{SCL} =400KHz	0.6	-	-	μs
Bus capacitance	CB	-	-	-	400	pF
Pulse width of suppressed spike	T _{SP}	-	0	-	50	ns

Note 1: CB is in pF.

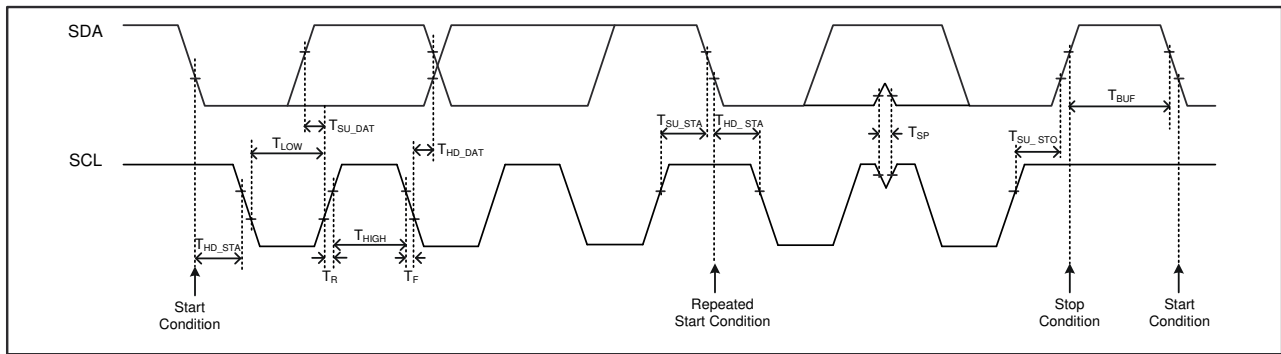

Figure 4 I²C serial-interface timing diagram



10. Function Description

The HX5330 provides I²C programmable voltage and frequency AC driving output. It also supports absence LC Lens detection and heater function.

10.1 Digital to analog converter (DAC)

The HX5330 includes **6-bit** Digital to analog converter (DAC). The DAC can support 0V to $V_{max} = 15V$, $VAP[5:0] =$ decimal equivalent (0~63) of the binary code that is loaded to the DAC register. Determining the output voltage use the following equation:

$$\text{Output Voltage: } V_{AA} = (V_{max}/64) * (VAP[5:0] + 1)$$

10.2 I²C protocol

The data on the SDA line must be stable during the HIGH period of the clock. The HIGH or LOW state of the data line can only change when the clock signal on the SCL line is LOW.

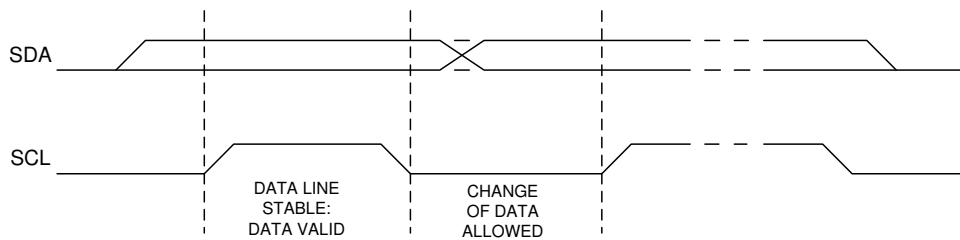

Figure 5 I²C Signal Timing

Within the procedure of the I²C-bus, unique situations arise which are defined as START and STOP conditions. A HIGH to LOW transition on the SDA line while SCL is HIGH is one such unique case. This situation indicates a START condition. A LOW to HIGH transition on the SDA line while SCL is HIGH defines a STOP condition. START and STOP conditions are always generated by the master. The I²C bus is considered to be busy after the START condition. The I²C bus is considered to be free again a certain time after the STOP condition.

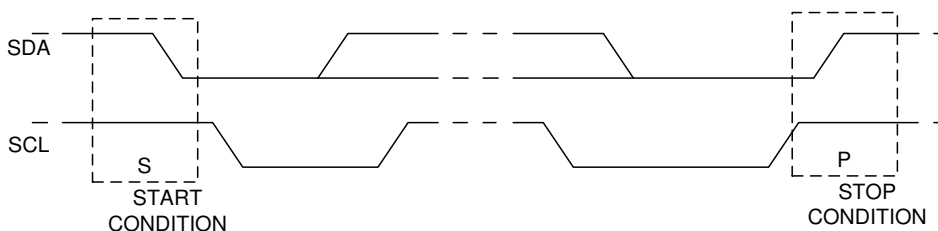

Figure 6 I²C Start/Stop



Every byte put on the SDA line must be 8-bits long. The number of bytes that can be transmitted per transfer is unrestricted. Each byte has to be followed by an acknowledge bit. Data is transferred with the most significant bit (MSB) first.

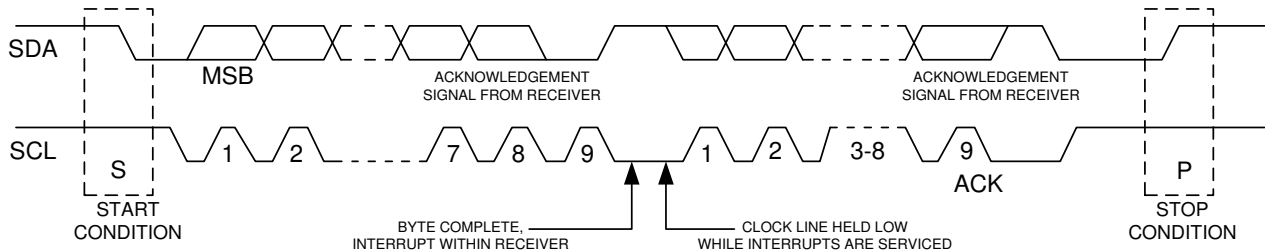

Figure 7 I²C Data Transfer

10.2.1 I²C protocol definition

S	START
AS	ACK SLAVE
AM	ACK MASTER
NA	NO ACK
P	STOP

10.2.2 I²C slave address

HX5330 has two slave address could be select by setting HW pin "ID". The slave address of I²C selected by ID pin is defined a follow table.

Table 1 Slave Address Table

ID	Slave address (A6-A0)
0	1110100
1	1110101

10.2.2 Write-mode

S	Device address							AS	Register address	AS	First data (8-bit)	AS	...	Last data (8-bit)	AS	P
	1	1	1	0	1	0	ID		0		Start address					



10.2.3 Read-mode

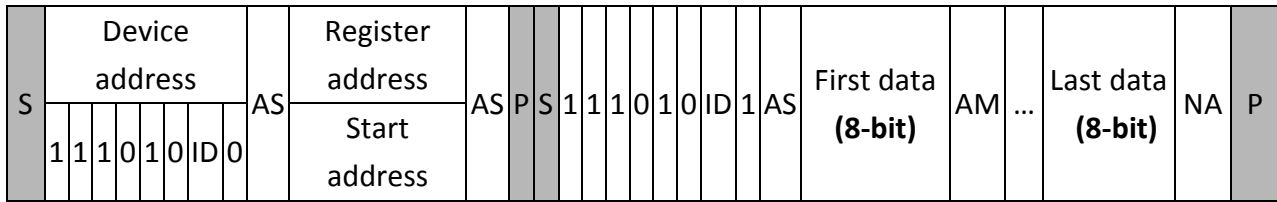

10.3 I²C command list and description

Address	R/W	D7	D6	D5	D4	D3	D2	D1	D0	Initial code
0x00h	W/R	0	1	0	1	1	0	1	0	0x00h
0x01h	W/R	Sleep_EN	LCEN_DIS	Safety_EN	Over_drive	LCBPIN_DS	LCCPIN_EN	LCCOU_T_EN	Spot_EN	0x01h
0x02h	R	-	-	-	-	-	-	ERR_FG	MOD	0x00h
0x03h	R/W	-	-	Output Voltage VAP[5:0]						0x3Fh
0x04h	R/W	Frequency FAP[7:0]								0x13h
0x05h	R/W	Safety_Dis	Over_Drive	Over drive Voltage VOP[5:0]						0x40h

Figure 8 I²C command list and description

10.3.1 Write protect register address: 0x00h (Default value)

Address	R/W	D7	D6	D5	D4	D3	D2	D1	D0	Initial code
		Write Protection								
0x00h	W/R	0	1	0	1	1	0	1	0	0x00h(*1)

Note 1: Programming correct value (5Ah) to enable registers' access. Please avoid to program A5h and 69h which is reserved for test mode.

10.3.2 Control register address: 0x01h (Default value)

Address	R/W	D7	D6	D5	D4	D3	D2	D1	D0	Initial code
		Control register								
0x01h	W/R	Sleep_EN	LCEN_DIS	Safety_EN	Over_drive	LCBPIN_DS	LCCPIN_EN	LCCOU_T_EN	Spot_EN	0x01h



The below show the controll bit detail information:

Spot_EN	Output enable
0	LCA, LCB, LCC keep 0V
1	LCA, LCB, LCC enable output (*2)

Note 2: LCA, LCB, LCC output is controled by LC_EN and Spot_EN. Both LC_EN=H and Spot_EN=H control LCA, LCB and LCC output voltage

LCCOUT_EN	LCC Output phase
0	LCC, LCA with the same output phase
1	LCC, LCA with 180° output phase

LCCPIN_EN	LCC Output enable
0	LCC disable output
1	LCC enable output

LCBPIN_DS	LCB Output phase
0	LCB, LCA with 180° output phase
1	LCB, LCA with the same output phase

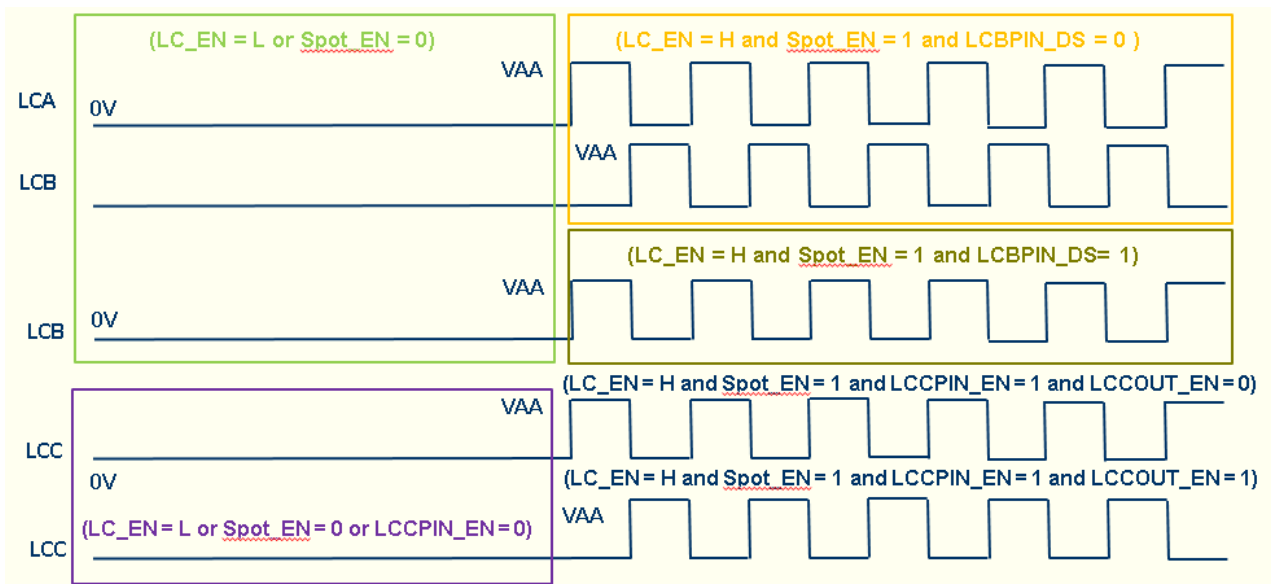

Figure 9 LC_EN, Spot_EN, LCCOUT_EN, LCCPIN_EN, LCBPIN_DS functions

Over_drive	Over drive function enable
0	Disable over drive function
1	Enable over drive function (*3)



Note 3: Over_Drive can be auto clear to 0 by hardware.

Safety_EN	Safety detection function enable
0	Disable safety detection function
1	Enable safety detection function (*4)

Note 4: Safety_EN can be auto clear to 0 by hardware.

LCEN_DIS	Safety detection function enable
0	LC_EN normally function
1	Disable LC_EN function

Sleep_EN	Sleep function enable
0	Normal mode
1	Enter sleep mode

10.3.3 Safety detection status: 0x00h (Default value)

Address	R/W	D7	D6	D5	D4	D3	D2	D1	D0	Initial code
		Status								
0x02h	R	-	-	-	-	-	-	ERR_FG	MOD	0x00h

The below show the tatus bit detail information:

MOD	LCC Output phase
0	LCA, LCB, LCC keep 0V
1	LCA, LCB/LCC has output voltage

ERR_FG	Error detection flag
0	Normally
1	LC Lens damaged

10.3.4 Heater and Output voltage: 0x3Fh (Default value)

Address	R/W	D7	D6	D5	D4	D3	D2	D1	D0	Initial code
		-	-	Output Voltage (V _{AA})						
0x03h	R/W	-	-	Output Voltage VAP[5:0]						0x3Fh



The below show the output voltage detail information:

Output Voltage	D5	D4	D3	D2	D1	D0
V_{AA}	Output Voltage VAP[5:0]					

$$\text{Output Voltage: } V_{AA} = (V_{\max}/64) * (VAP[5:0] + 1), V_{\max} = 15V$$

10.3.5 Output AC frequency: 0x13h (Default value)

Address	R/W	D7	D6	D5	D4	D3	D2	D1	D0	Initial code
		Output AC frequency (f)								
0x04h	R/W	Frequency FAP[7:0]								0x13h

$$\text{Output frequency: } f = (12.8\text{kHz} * (FAP[7:0] + 1) / 256), FAP[7:0] = 0x00h, f = 50\text{Hz}$$

10.3.6 Over drive voltage: 0x40h (Default value)

Address	R/W	D7	D6	D5	D4	D3	D2	D1	D0	Initial code
		LC_EN Safety disable	Over drive disable	Over drive voltage ($V_{\text{over drive}}$)						
0x05h	R/W	Safety_ Dis	Over_ Dis	Over drive Voltage VOP[5:0]						0x40h

The below show the LC_EN trigger to safety detection function detail information:

Safety_Dis	LC_EN safety disable
0	Normally
1	LC_EN trigger to safety detection function is disable

The below show the Over drive disable function detail information:

Safety_Dis	LC_EN safety disable
0	Normally
1	Over drive function is disable

The below show the Over drive voltage detail information:

Over drive Voltage	D5	D4	D3	D2	D1	D0
$V_{\text{over drive}}$	Over drive Voltage VOP[5:0]					



Over drive voltage: $V_{\text{over drive}} = (V_{\text{max}} / 64) * (VOP[5:0] + 1)$, $V_{\text{max}} = 15V$

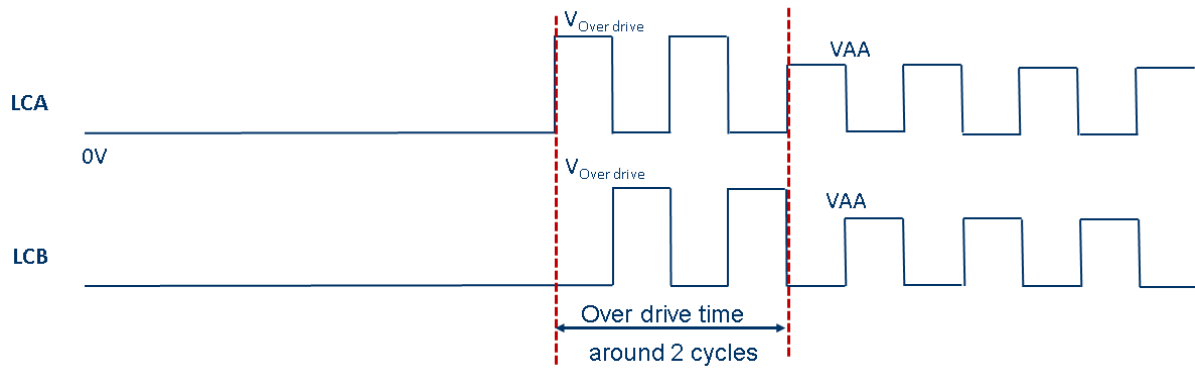

Figure 10 Over drive voltage illustration



11. Application Information

11.1 Operation flow chart

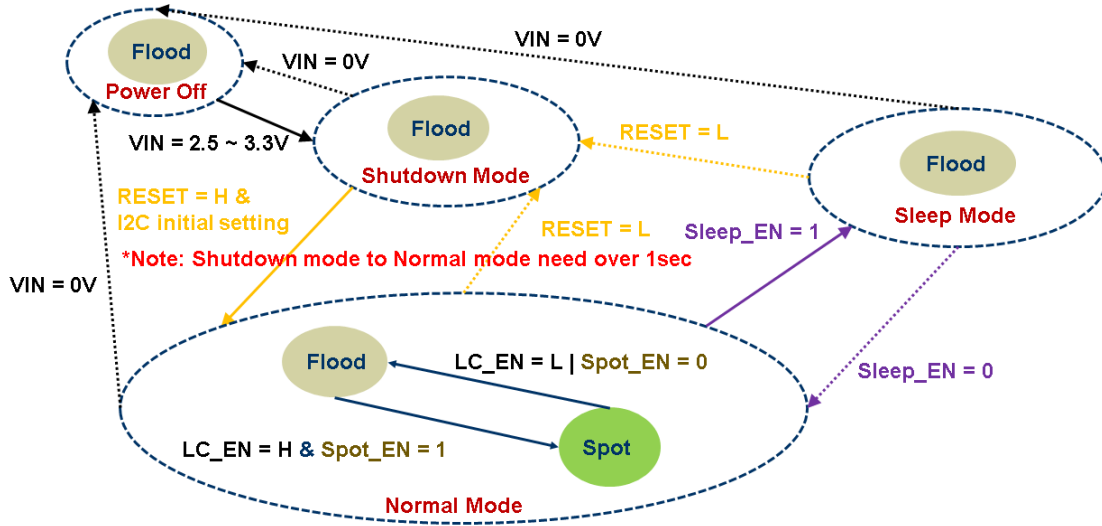

Figure 101 Operation flow chart

11.2 Safety Detection Function

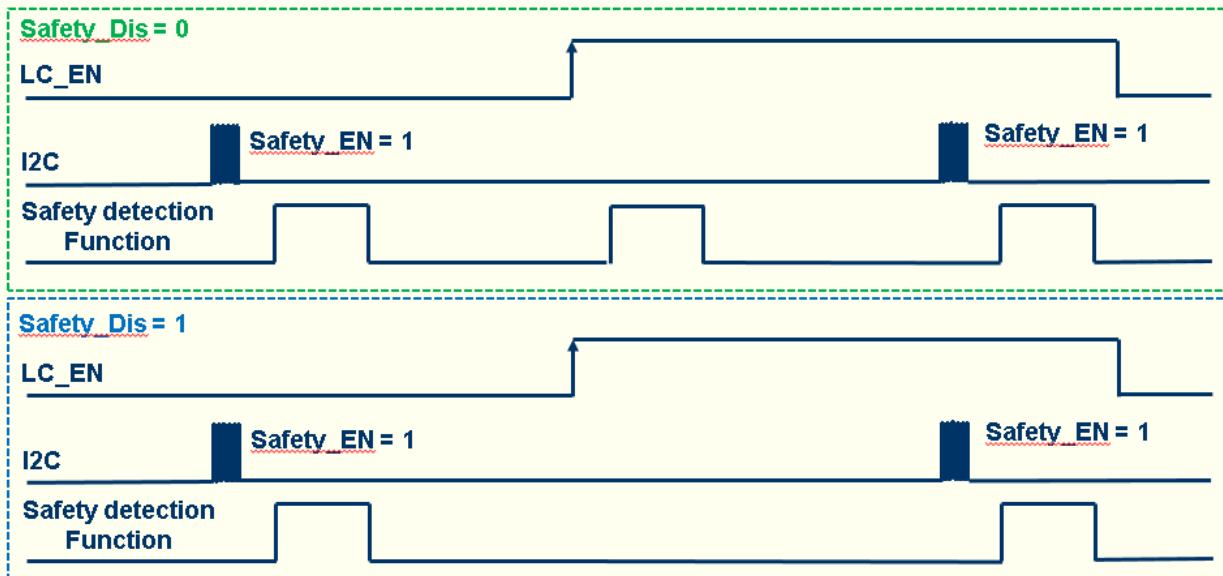

Figure 112 Safety detection function operation



11.3 Over Drive Function

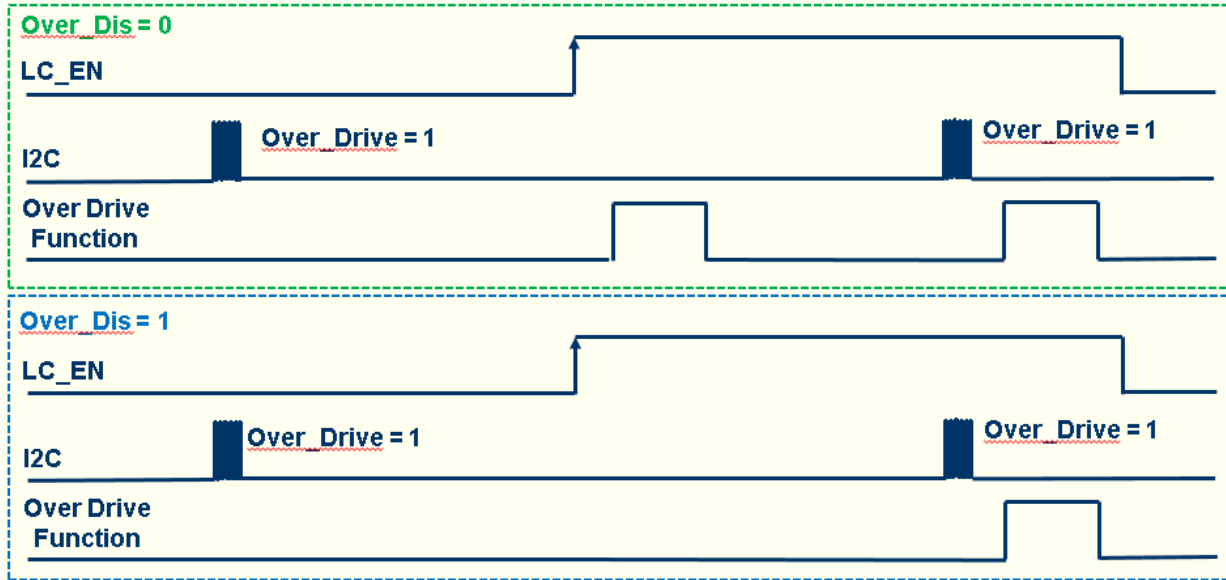

Figure 123 Over drive function operation

11.4 Application Reference Circuit

Case A: without external HAVDD

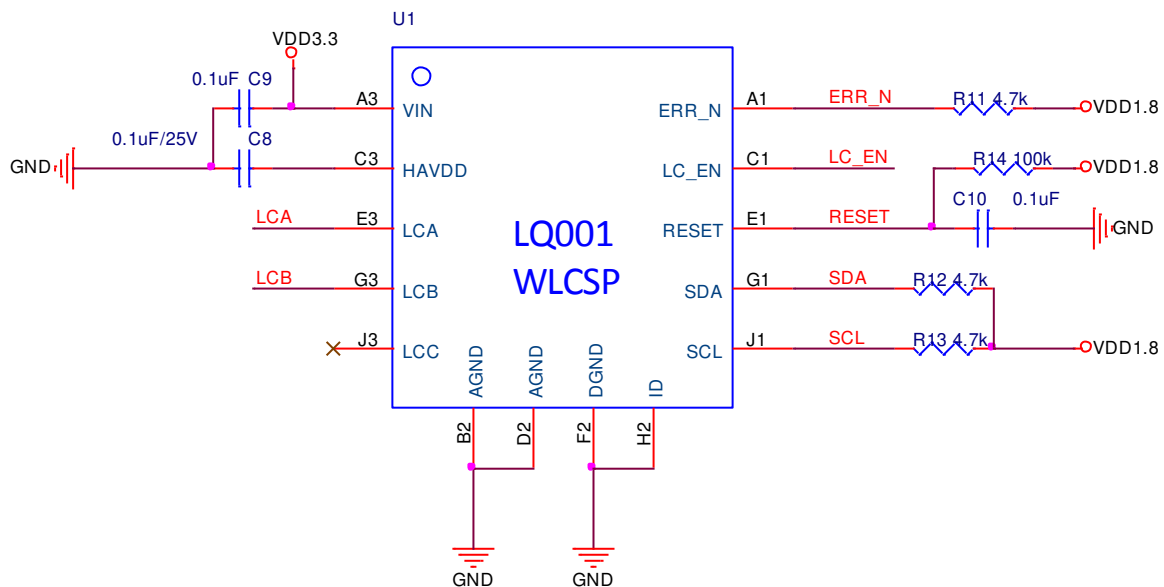

Figure 134 Application circuit (For Load Capacitance < 2uF)



Case B: with external HAVDD (15V)

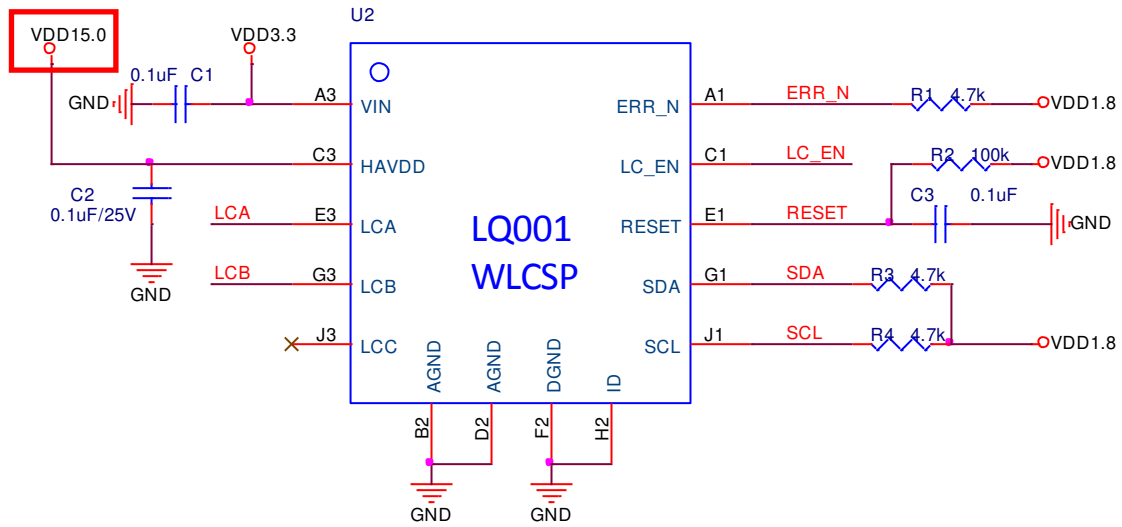

Figure 145 Application circuit (External 15V power)

11.5 Power Sequence

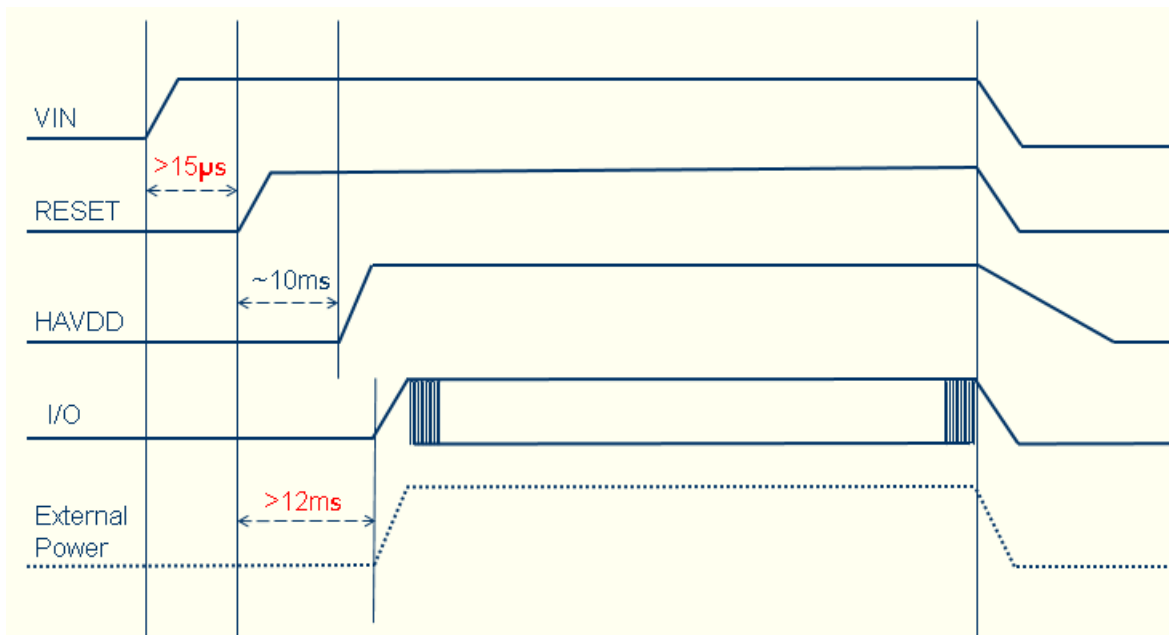

Figure 156 Power sequence



11.6 External Power

If LC Lens's C1 is over 3 μ F or R1, R2 is over 33k Ω [Fig 17], Please used external power (15V) supply to HAVDD. The external power need follow the power sequence [Fig 16].

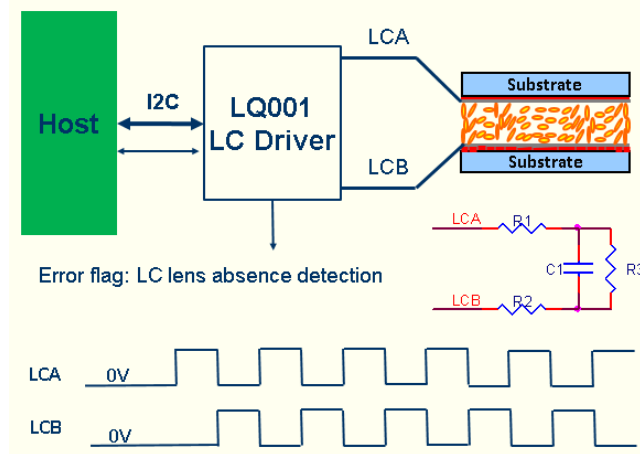

Figure 167 Simplified application diagram with LC Lens RC model



12. Package Outline Dimension

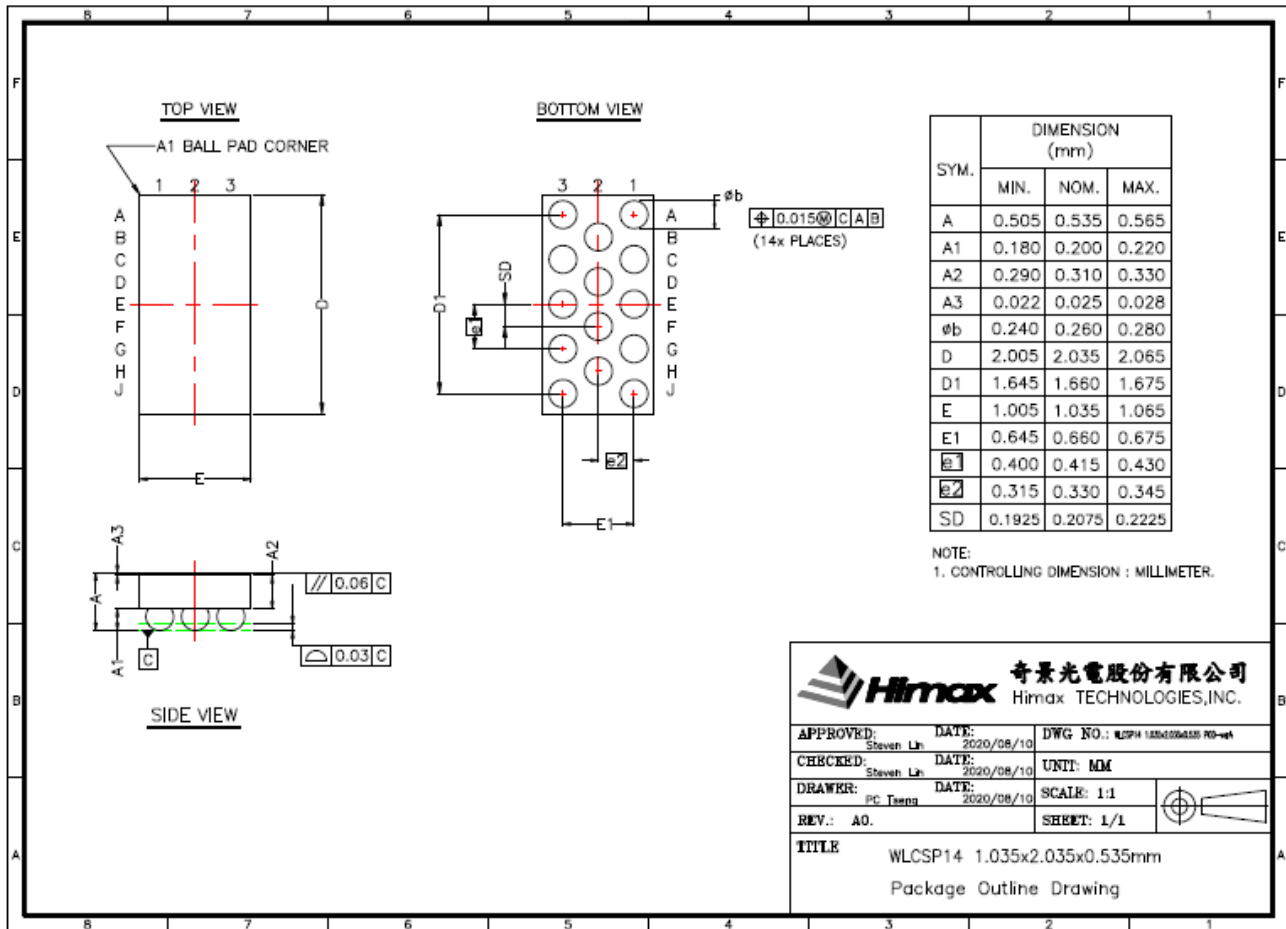

Figure 178 Package Outline Dimension

13. Ordering Information

Part no.	Package
HX5330	WLCSP 14L 1.035x2.035x0.535mm

14. Remarks

HX5330 is also named as LQ001 from Liqxtal technology.