



MAXIM

3V, Ultra-Low-Power Quadrature Demodulator

MAX2451

General Description

The monolithic MAX2451 is a quadrature demodulator with a supporting oscillator and divide-by-8 prescaler. It operates from a single +3V supply and draws only 5.5mA. The demodulator accepts an amplified and filtered IF signal in the 35MHz to 80MHz range, and demodulates it into I and Q baseband signals with 51dB of voltage conversion gain. The IF input is terminated with a 400Ω thin-film resistor for matching to an external IF filter. The baseband outputs are fully differential and have 1.2Vp-p signal swings.

Pulling the CMOS-compatible ENABLE pin low shuts down the MAX2451 and reduces the supply current to less than 2μA, typical. To minimize spurious feedback, the MAX2451's internal oscillator is set at twice the IF frequency via external tuning components. The MAX2451 comes in a 16-pin narrow SO package.

Applications

Digital Cordless Phones
GSM and North American Cellular Phones
Wireless LANs
Digital Communications
Pagers

Pin Configuration

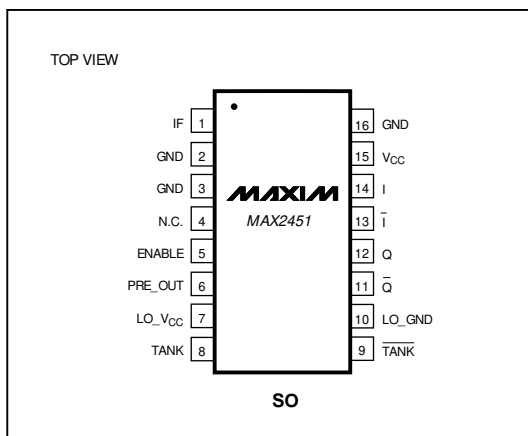

Features

- ♦ Integrated Quadrature Phase Shifters
- ♦ On-Chip Oscillator (Requires External Tuning Circuit)
- ♦ 51dB Voltage Conversion Gain
- ♦ On-Chip Divide-by-8 Prescaler
- ♦ Baseband Output Bandwidth Up to 9MHz
- ♦ CMOS-Compatible Enable
- ♦ 5.5mA Operating Supply Current
2μA Shutdown Supply Current

Ordering Information

PART	TEMP. RANGE	PIN-PACKAGE
MAX2451CSE	0°C to +70°C	16 Narrow SO

Functional Diagram

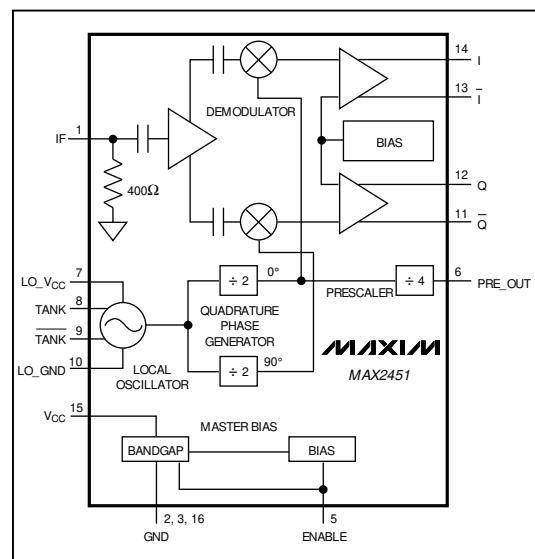

MAXIM

Maxim Integrated Products 1

Call toll free 1-800-998-8800, or visit our WWW site at <http://www.maxim-ic.com> for free samples or the latest literature.

3V, Ultra-Low-Power Quadrature Demodulator

ABSOLUTE MAXIMUM RATINGS

V _{CC} , LO_V _{CC} to GND.....	-0.3V to +4.5V	Continuous Power Dissipation (T _A = +70°C)	
ENABLE, TANK, \bar{TANK} , I, \bar{I} , Q, \bar{Q} to GND.....	-0.3V to (V _{CC} + 0.3V)	Narrow SO (derate 8.70mW/°C above +70°C)	696mW
IF to GND.....	-0.3V to +1.5V	Operating Temperature Range.....	0°C to +70°C
		Storage Temperature Range	-65°C to +165°C
		Lead Temperature (soldering, 10sec)	+300°C

Stresses beyond those listed under "Absolute Maximum Ratings" may cause permanent damage to the device. These are stress ratings only, and functional operation of the device at these or any other conditions beyond those indicated in the operational sections of the specifications is not implied. Exposure to absolute maximum rating conditions for extended periods may affect device reliability.

DC ELECTRICAL CHARACTERISTICS

(V_{CC} = LO_V_{CC} = \bar{TANK} = +2.7V to +3.3V, ENABLE = V_{CC} - 0.4V, GND = LO_GND = 0V, I = \bar{I} = Q = \bar{Q} = IF = TANK = OPEN, T_A = 0°C to +70°C, unless otherwise noted.)

PARAMETER	SYMBOL	CONDITIONS	MIN	TYP	MAX	UNITS
Supply Voltage Range	V _{CC} , LO_V _{CC}		2.7		3.3	V
Supply Current	I _{CC(ON)}			5.5	7.4	mA
Shutdown Supply Current	I _{CC(OFF)}	Enable = 0.4V		2	20	μA
Enable/Disable Time	t _{ON/OFF}			10		μs
ENABLE Bias Current	I _{EN}			1	3	μA
ENABLE High Voltage	V _{ENH}		V _{CC} - 0.4			V
ENABLE Low Voltage	V _{ENL}				0.4	V
IF Input Impedance	Z _{IN}		320	400	480	Ω
I, \bar{I} , Q, \bar{Q} Voltage Level	V _{I/\bar{I}} , V _{Q/\bar{Q}}			1.2		V
Baseband I and Q DC Offset				±11	±50	mV

AC ELECTRICAL CHARACTERISTICS

V_{CC} = LO_V_{CC} = ENABLE = 3.0V, f_{LO} = 140MHz, f_{IF} = 70.1MHz, V_{IF} = 2.82mVp-p, T_A = +25°C, unless otherwise noted.)

PARAMETER	SYMBOL	CONDITIONS	MIN	TYP	MAX	UNITS
Baseband I and Q Amplitude Balance				< ±0.45		dB
Baseband I and Q Phase Accuracy				< ±1.3		degrees
Voltage Conversion Gain				51		dB
Noise Figure	NF			18		dB
Allowable I and Q Voltage Swing		(Note 1)			1.35	Vp-p
I and Q IM3 Level	IM _{3I/Q}	(Note 2)		-44		dBc
I and Q IM5 Level	IM _{5I/Q}	(Note 2)		-60		dBc
I and Q Signal 3dB Bandwidth	BW _{3dB}			9		MHz
Oscillator Frequency Range	f _{LO}	(Notes 1, 3)	70		160	MHz
PRE_OUT Output Voltage	V _{PRE_OUT}	R _L = 10kΩ, C _L < 6pF		0.35		Vp-p
PRE_OUT Slew Rate	SR _{PRE_OUT}	R _L = 10kΩ, C _L < 6pF, rising edge		60		V/μs
Oscillator Phase Noise		Offset = 10kHz		-80		dBc/Hz

Note 1: Guaranteed by design, not tested.

Note 2: f_{IF} = 2 tones at 70.10MHz and 70.11MHz, V_{IF} = 1.41mVp-p per tone.

Note 3: Oscillator frequencies up to 1GHz (500MHz IF) by externally overdriving (see *Applications Information*).

3V, Ultra-Low-Power Quadrature Demodulator

Typical Operating Characteristics

($V_{CC} = LO_V_{CC} = ENABLE = 3.0V$, $f_{LO} = 140MHz$, $f_{IF} = 70.1MHz$, $V_{IF} = 2.82mV_{p-p}$, $T_A = +25^{\circ}C$, unless otherwise noted.)

MAX2451

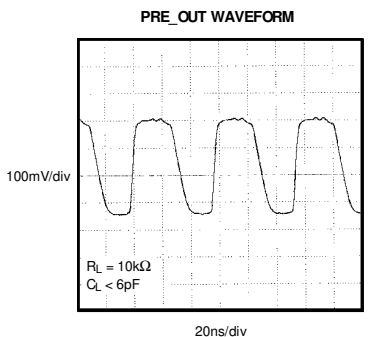
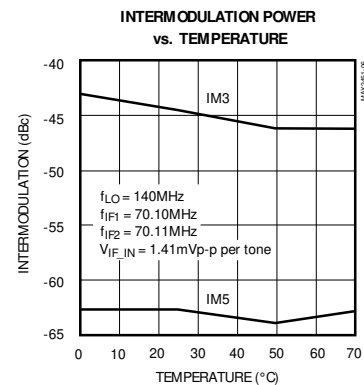
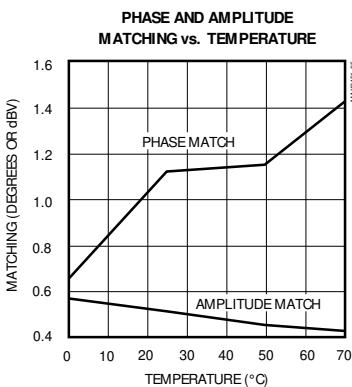
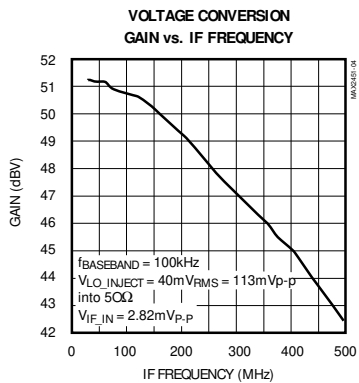
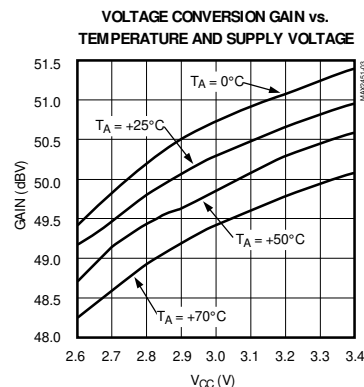
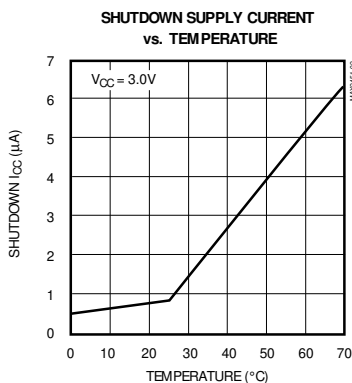
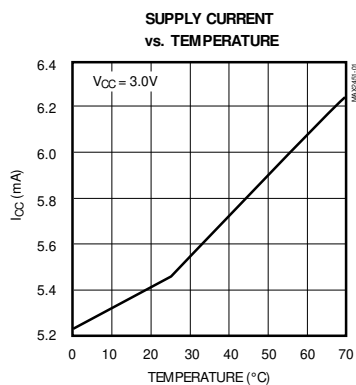

3V, Ultra-Low-Power Quadrature Demodulator

Pin Description

PIN	NAME	FUNCTION
1	IF	IF Input
2, 3, 16	GND	Ground
4	N.C.	No Connect. No internal connection to this pin.
5	ENABLE	Enable Control, active high
6	PRE_OUT	Local-Oscillator Divide-by-8 Prescaled Output
7	LO_VCC	Local-Oscillator Supply. Bypass separately from Vcc.
8	TANK	Local-Oscillator Resonant Tank Input
9	\bar{TANK}	Local-Oscillator Resonant Tank Inverting Input
10	LO_GND	Local-Oscillator Ground
11	\bar{Q}	Baseband Quadrature Inverting Output
12	Q	Baseband Quadrature Output
13	\bar{I}	Baseband Inphase Inverting Output
14	I	Baseband Inphase Output
15	VCC	Demodulator Supply

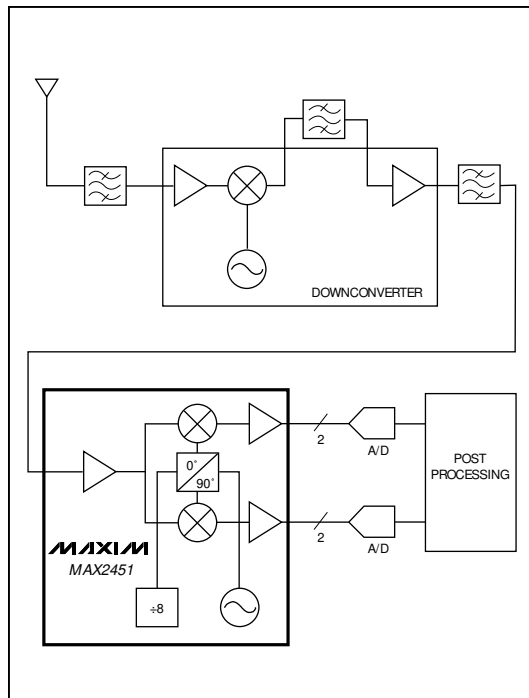

Figure 1. Typical Application Block Diagram

Detailed Description

The following sections describe each of the functional blocks shown in the *Functional Diagram*. Also refer to the Typical Application Block Diagram (Figure 1).

Demodulator

The demodulator contains a single-ended-to-differential converter, two Gilbert-cell multipliers, and two fixed gain stages. Internally, IF is terminated with a 400 Ω resistor to GND. The IF input signal is AC coupled into the input amplifier, which has 14dB of gain. This amplified IF signal is fed into the I and Q channel mixers for demodulation. The multipliers mix the IF signal with the quadrature LO signals, resulting in baseband I and Q signals. The conversion gain of the multipliers is 15dB. These signals are further amplified by 21dB by the baseband amplifiers. The baseband amplifier chains are DC coupled.

Local Oscillator

The local-oscillator section is formed by an emitter-coupled differential pair. Figure 2 shows the local-oscillator equivalent circuit schematic. An external LC resonant tank determines the oscillation frequency, and the Q of this resonant tank affects the oscillator phase noise. The oscillation frequency is twice the IF frequency, for easy generation of quadrature signals.

The oscillator may be overdriven by an external source. The source should be AC coupled into TANK/ \bar{TANK} , and should provide 200mVp-p levels. A choke (typically 2.2 μ H) is required between TANK and \bar{TANK} . Differential input impedance at TANK/ \bar{TANK} is 10k Ω . For single-ended drive, connect an AC bypass capacitor (1000pF) from \bar{TANK} to GND, and AC couple TANK to the source.

The oscillator can be overdriven at frequencies up to 1GHz (500MHz IF), but conversion gain and prescaler output levels will be somewhat reduced.

3V, Ultra-Low-Power Quadrature Demodulator

MAX2451

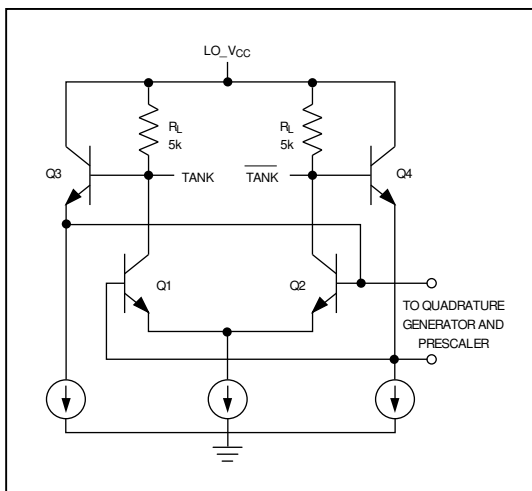

Figure 2. Local-Oscillator Equivalent Circuit

Quadrature Phase Generator

The quadrature phase generator uses two latches to divide the local-oscillator frequency by two, and generates two precise quadrature signals. Internal limiting amplifiers shape the signals to approximate square waves to drive the Gilbert-cell mixers. The inphase signal (at half the local oscillator frequency) is further divided by four for the prescaler output.

Prescaler

The prescaler output, PRE_OUT, is buffered and swings typically 0.35Vp-p with a 10kΩ and 6pF load. It can be AC coupled to the input of a frequency synthesizer.

Master Bias

During normal operation, ENABLE should be above VCC - 0.4V. Pulling the ENABLE input low shuts off the master bias and reduces the circuit current to typically 2μA. The master bias section includes a bandgap reference generator and a PTAT (Proportional To Absolute Temperature) current generator.

Applications Information

Figure 3 shows the implementation of a resonant tank circuit. The inductor, two capacitors, and a dual varactor form the oscillator's resonant circuit. In Figure 3, the oscillator frequency ranges from 130MHz to 160MHz. To ensure reliable start-up, the inductor is directly connected across the local oscillator's tank ports. The two 33pF capacitors affect the Q of the resonant circuit. Other values may be chosen to meet individual appli-

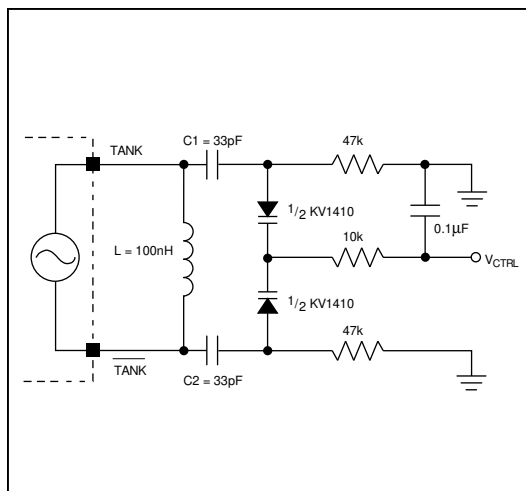

Figure 3. Typical Resonant Tank Circuit

cation requirements. The oscillation frequency can be determined using the following formula:

$$f_o = \frac{1}{2\pi\sqrt{L_{EQ}C_{EQ}}}$$

where

$$C_{EQ} = \frac{1}{\frac{1}{C1} + \frac{1}{C2} + \frac{2}{C_{VAR}}} + C_{STRAY}$$

and

$$L_{EQ} = L + L_{STRAY}$$

where CSTRAY = parasitic capacitance and LSTRAY = parasitic inductance.

To alter the oscillation frequency range, change the inductance, the capacitance, or both. For best phase-noise performance, keep the Q of the resonant tank as high as possible:

$$Q = R_{EQ} \sqrt{\frac{C_{EQ}}{L_{EQ}}}$$

where REQ ≈ 10kΩ (Figure 2).

The oscillation frequency can be changed by altering the control voltage, VCTRL.

MAX2451

3V, Ultra-Low-Power Quadrature Demodulator

Package Information

**Narrow SO
SMALL-OUTLINE
PACKAGE
(0.150 in.)**

DIM	INCHES		MILLIMETERS	
	MIN	MAX	MIN	MAX
A	0.053	0.069	1.35	1.75
A1	0.004	0.010	0.10	0.25
B	0.014	0.019	0.35	0.49
C	0.007	0.010	0.19	0.25
E	0.150	0.157	3.80	4.00
e	0.050		1.27	
H	0.228	0.244	5.80	6.20
L	0.016	0.050	0.40	1.27

DIM	PINS	INCHES		MILLIMETERS	
		MIN	MAX	MIN	MAX
D	8	0.189	0.197	4.80	5.00
D	14	0.337	0.344	8.55	8.75
D	16	0.386	0.394	9.80	10.00

21-0041A

Maxim cannot assume responsibility for use of any circuitry other than circuitry entirely embodied in a Maxim product. No circuit patent licenses are implied. Maxim reserves the right to change the circuitry and specifications without notice at any time.

6 Maxim Integrated Products, 120 San Gabriel Drive, Sunnyvale, CA 94086 (408) 737-7600

© 1995 Maxim Integrated Products Printed USA **MAXIM** is a registered trademark of Maxim Integrated Products.