

| PART NUMBER | REV | FIRST USED |
|-------------|-----|------------|
| 680303-1 | A | 122500-1 |
| 680303-2 | A | 565435-5 |

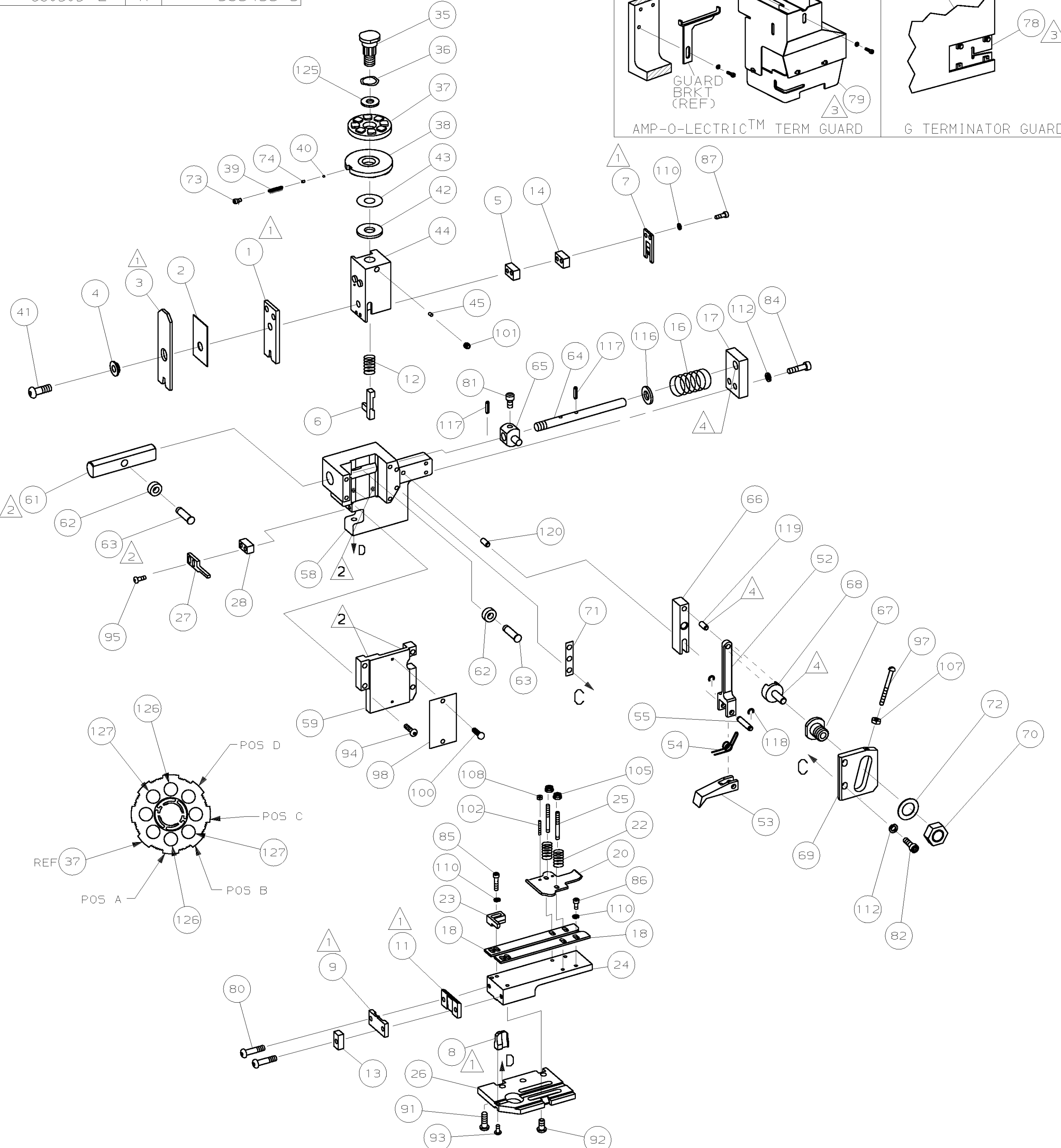
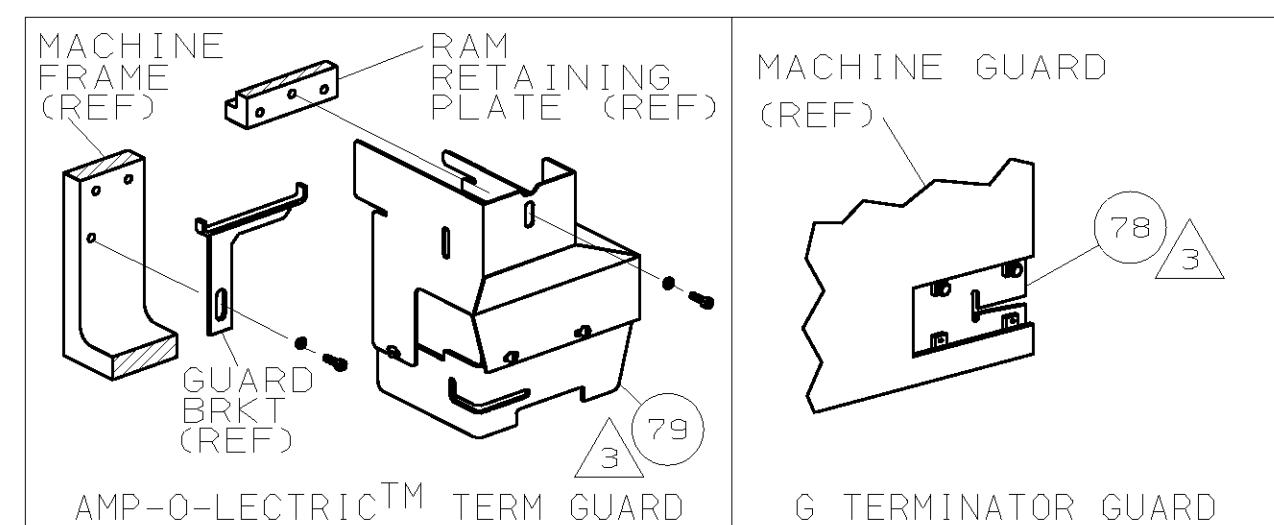

| TERMINAL NAME: RECEPTACLE | | 356308 | | CRIMPING DATA | |
|---------------------------|---------------------------|-----------|------------|------------------|-------------|
| PAD LTR | CRIMP HEIGHT | WIRE SIZE | | | |
| A | .067 ±.002 [1.70 ±0.05mm] | 16 | | | |
| B | .059 ±.002 [1.50 ±0.05mm] | 18 | | | |
| C | NOT | USED | | | |
| D | NOT | USED | | | |
| CRIMP | SIZE | TYPE | RANGE | | |
| WIRE | .090 [2.29mm] | F | 18-16 | | |
| INSUL | .140 [3.56mm] | F | Ø.115-.121 | | |
| WIRE STRIP LENGTH | TERM APPL | SPEC | FEED | APPL INSTRUCTION | SET UP GAGE |
| - | NONE | | .868 | 408-8039 | 458638-1 |
| | | | | | LAYOUT |
| | | | | | L1764 |

| LEADMAKER & BENCH MODEL G | | MECH POST FEED | | | |
|---------------------------|-----|----------------|---|----------|---------------------|
| REF | REF | - | A | 22594-8 | NUT, HEX |
| REF | REF | - | B | 240628-1 | PLATE, ADJ |
| REF | REF | - | B | 240626-1 | SHAFT, PIVOT |
| REF | REF | - | B | 240633-1 | BUSHING |
| REF | REF | - | A | 455680-1 | LEVER, INTERMEDIATE |
| REF | REF | - | B | 240629-1 | BLOCK, PIVOT |
| REF | REF | - | A | 240632-2 | SCR, ADJ |
| REF | REF | - | B | 240659-3 | PIN, CAM ROLLER |
| REF | REF | - | B | 240658-1 | CAM, ROLLER |
| REF | REF | - | B | 454398-1 | ROD, FEED |

| | | | | | | |
|-----|-----|---|---|------------|----------------------------------|-----|
| | | | | | | 129 |
| | | | | | | 128 |
| 2 | 2 | - | C | 1-354779-4 | PIN, WIRE DISC (.3060)B | 127 |
| 2 | 2 | - | C | 9-354778-6 | PIN, WIRE DISC (.2975)A | 126 |
| 1 | 1 | - | A | 986950-1 | WASHER, FLAT PRECISION | 125 |
| 1 | 1 | - | A | 217238-1 | GENERAL INSTRUCTION PACKAGE | 124 |
| 1 | 1 | - | - | 4088039 | EF APPL INST 408-8039 | 123 |
| | | | | | | 122 |
| | | | | | | 121 |
| REF | REF | - | A | 1-21030-7 | PIN, DOWEL (Ø.187x1.50)H5G | 120 |
| REF | REF | - | A | 1-21030-1 | PIN, DOWEL (Ø.187x.50)LEVER | 119 |
| REF | REF | - | A | 21045-3 | RING, RET "C" (Ø.187)FD PIN | 118 |
| REF | REF | - | A | 5-21028-1 | PIN, STD SPRING (Ø.12)FD ADJ ROD | 117 |
| REF | REF | - | A | 21899-4 | WASHER, FLAT (Ø5/16)SCR ADJ | 116 |
| | | | | | | 115 |
| | | | | | | 114 |
| | | | | | | 113 |
| REF | REF | - | A | 21024-5 | WASHER, LOCK (NO.10)FD ROD GDE | 112 |
| | | | | | | 111 |
| 7 | 7 | - | A | 21024-4 | WASHER, LOCK (NO.8)SHEAR BL | 110 |
| | | | | | | 109 |
| 2 | 2 | - | A | 21018-4 | NUT, HEX (4-40)DRAG | 108 |
| REF | REF | - | A | 21018-5 | NUT, HEX (6-32)FD ADJ PL | 107 |
| | | | | | | 106 |
| 2 | 2 | - | A | 21022-2 | NUT, HEX 5L (8-32)DRAG STUD | 105 |
| | | | | | | 104 |
| | | | | | | 103 |
| 2 | 2 | - | A | 2-21006-6 | SCR, SKT SET (4-40x.62)DRAG | 102 |
| 1 | 1 | - | A | 21009-2 | SCR, SKT SET (1/4-20x.25)RAM | 101 |
| 2 | 2 | - | A | 21017-2 | SCR, DRIVE (#2x.19) ID PLATE | 100 |
| 1 | 1 | - | A | 1-21002-7 | SCR, BHC (6-32x.38)CAM | 99 |
| 1 | 1 | - | B | 461264-1 | PLATE, IDENTIFICATION | 98 |
| REF | REF | - | A | 6-23715-5 | SCR, PAN HD (6-32x1.50)FEED ADJ | 97 |
| | | | | | | 96 |
| 2 | 2 | - | A | 2-21002-2 | SCR, BHC (8-32x.50)STRIPPER | 95 |
| REF | REF | - | A | 2-21002-9 | SCR, BHC (10-32x.75)H5G CAP | 94 |
| 1 | 1 | - | A | 22733-8 | SCR, BHC (8-32x.38 LW)ANVIL | 93 |
| 4 | 4 | - | A | 3-21002-3 | SCR, BHC (1/4-20x.50)ST 6D PL | 92 |
| REF | REF | - | A | 2-22733-8 | SCR, BHC (1/4-20x.62)BASE PL | 91 |
| | | | | | | 90 |
| | | | | | | 89 |
| | | | | | | 88 |
| 2 | 2 | - | A | 2-21000-7 | SCR, 5HC (8-32x.50)SLUG BLADE | 87 |
| 3 | 3 | - | A | 2-21000-6 | SCR, 5HC (8-32x.38)STRIP GUIDE | 86 |
| 2 | 2 | - | A | 2-21000-9 | SCR, 5HC (8-32x.75)R STRIP GUIDE | 85 |
| REF | REF | - | A | 3-21000-7 | SCR, 5HC (10-32x.75)FEED ROD GDE | 84 |
| | | | | | | 83 |
| REF | REF | - | A | 3-21000-6 | SCR, 5HC (10-32x.62)FEED ADJ PL | 82 |
| REF | REF | - | A | 3-21000-4 | SCR, 5HC (10-32x.38)PIVOT BLOCK | 81 |
| 2 | 2 | - | A | 3-21002-0 | SCR, BHC (10-32x.88)SHEAR PL | 80 |
| REF | REF | - | A | 455745-1 | GUARD, WINDOW | 79 |
| - | REF | - | A | 679532-1 | INSERT, GUARD | 78 |
| | | | | | | 77 |
| | | | | | | 76 |
| | | | | | | 75 |
| 1 | 1 | - | A | 690603-1 | SPRING, ASSIST | 74 |
| 1 | 1 | - | A | 23030-1 | SCR, SKT CAP (6-32x.25)CP DSC | 73 |
| REF | REF | - | A | 458109-1 | WASHER, FLAT (SPECIAL) | 72 |
| REF | REF | - | A | 690517-1 | SPACER | 71 |

| | | | | | | |
|-----|-----|---|---|------------|------------------------------|----|
| | | | | | | 60 |
| | | | | | | 59 |
| REF | REF | - | C | 454220-1 | CAP, RAM | 58 |
| REF | REF | - | D | 453736-1 | HOUSING | 57 |
| | | | | | | 56 |
| | | | | | | 55 |
| REF | REF | - | B | 240624-1 | PIN, FEED FINGER | 54 |
| REF | REF | - | B | 691499-1 | SPRING, FEED FINGER | 53 |
| REF | REF | - | B | 240635-1 | FINGER, FEED | 52 |
| REF | REF | - | B | 240634-1 | LEVER, TERMINAL | 51 |
| | | | | | | 50 |
| | | | | | | 49 |
| 1 | - | - | B | 690501-3 | CAM, POST FEED 1 1/8 ST | 48 |
| - | 1 | - | B | 690501-4 | CAM, POST-FEED 1 5/8 ST | 47 |
| | | | | | | 46 |
| 1 | 1 | - | A | 690191-1 | PLUG, NYLON | 45 |
| 1 | 1 | - | C | 455674-1 | RAM | 44 |
| 1 | 1 | - | A | 690125-1 | WASHER, LAMINATED | 43 |
| 1 | 1 | - | A | 690124-1 | WASHER, RAM | 42 |
| 1 | 1 | - | A | 7-21002-9 | BOLT, CRIMPER (5/16-24x1.00) | 41 |
| 1 | 1 | - | A | 23241-6 | BALL, STEEL | 40 |
| 1 | 1 | - | A | 690170-1 | SPRING, COMPRESSION | 39 |
| 1 | 1 | - | C | 690142-1 | DISC, INSULATION | 38 |
| 1 | 1 | - | D | 354777-1 | WIRE DISC, PLASTIC | 37 |
| 1 | 1 | - | A | 22480-5 | WASHER, SPRING | 36 |
| 1 | 1 | - | B | 690212-1 | POST, RAM | 35 |
| | | | | | | 34 |
| | | | | | | 33 |
| 1 | 1 | - | D | 458980-1 | APPLICATOR, BASIC (SUB ASSY) | 32 |
| | | | | | | 31 |
| | | | | | | 30 |
| | | | | | | 29 |
| 1 | 1 | - | B | 3-690451-2 | SPACER, STRIPPER | 28 |
| 1 | 1 | - | A | 240639-1 | STRIPPER | 27 |
| REF | REF | - | C | 455676-1 | PLATE, BASE | 26 |
| 2 | 2 | - | A | 22354-8 | DRAG, STUD | 25 |
| 1 | 1 | - | B | 458803-3 | PLATE, STRIP GUIDE | 24 |
| 1 | 1 | - | C | 240825-3 | PLATE, STRIP HOLD DOWN | 23 |
| 2 | 2 | - | A | 4-22281-1 | SPRING, DRAG | 22 |
| | | | | | | 21 |
| 1 | 1 | - | A | 454177-1 | DRAG, STOCK | 20 |
| | | | | | | 19 |
| 2 | 2 | - | C | 454204-3 | GUIDE, STRIP (FRONT) | 18 |
| REF | REF | - | A | 454178-1 | GUIDE, FEED ROD | 17 |
| REF | REF | - | A | 4-22284-9 | SPRING, FEED RETURN | 16 |
| | | | | | | 15 |
| 1 | 1 | - | C | 4-240641-9 | SPACER, SLUG BLADE | 14 |
| 1 | 1 | - | C | 690481-2 | SPACER, HOLD DOWN | 13 |
| 1 | 1 | - | A | 23846-1 | SPRING, HOLD DOWN | 12 |
| 1 | 1 | - | B | 240833-2 | PLATE, REAR SHEAR | 11 |
| | | | | | | 10 |
| 1 | 1 | - | B | 1-690495-6 | PLATE, FRONT SHEAR | 9 |
| 1 | 1 | - | D | 6-240655-0 | ANVIL | 8 |
| 1 | 1 | - | B | 690474-6 | BLADE, SLUG | 7 |
| 1 | 1 | - | D | 1-455892-4 | HOLD DOWN, TERMINAL | 6 |
| 1 | 1 | - | C | 6-240641-5 | SPACER, SLUG BLADE | 5 |
| 1 | 1 | - | B | 238009-8 | SPACER, BLOCK CRIMPER | 4 |
| 1 | 1 | - | C | 456134-3 | CRIMPER, INSULATION | 3 |
| 1 | 1 | - | B | 455888-3 | SPACER, CRIMPER | 2 |
| 1 | 1 | - | C | 1-456406-0 | CRIMPER, WIRE | 1 |

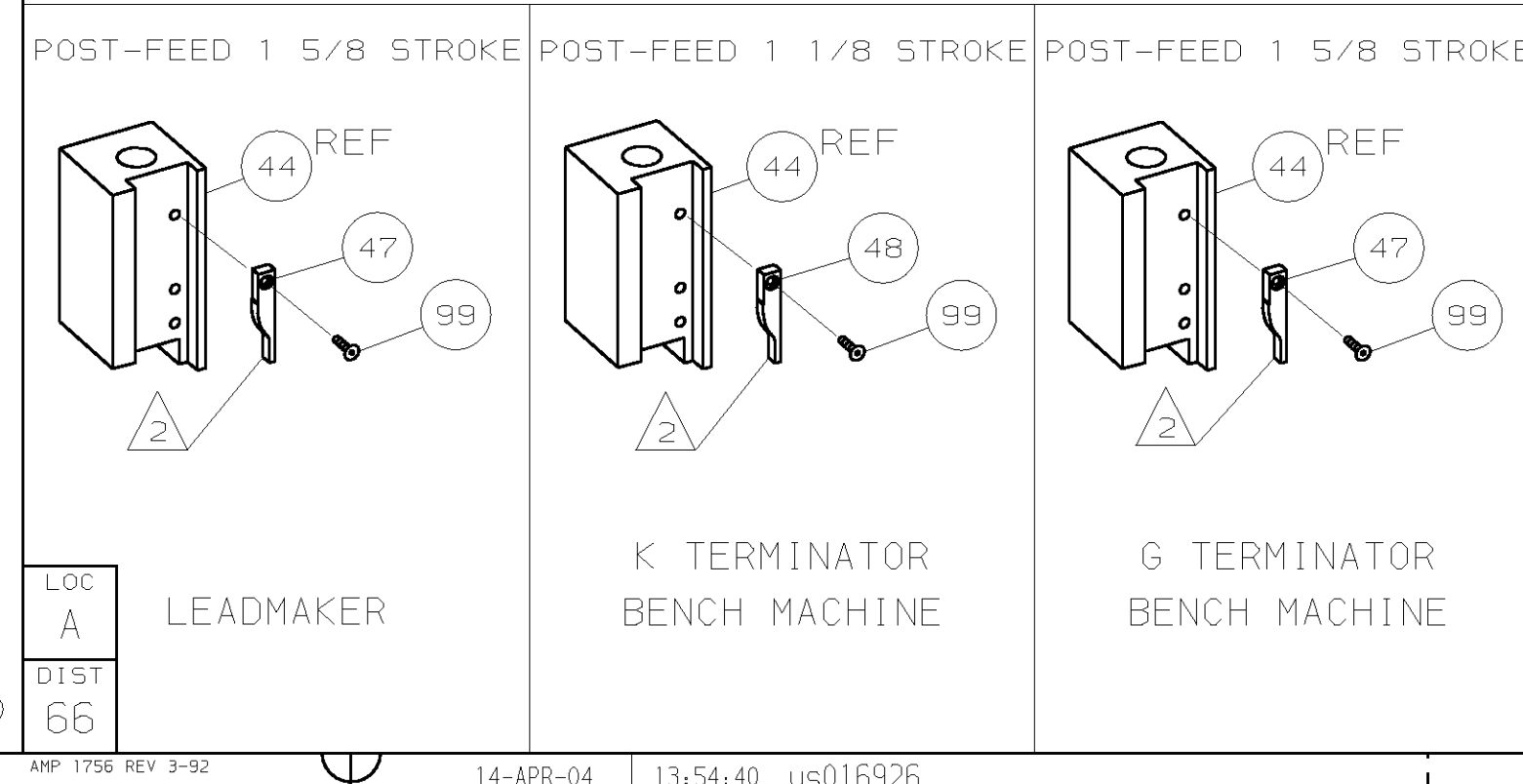

- 1 RECOMMENDED SPARE PARTS.
- 2 GREASE LIGHTLY.
- 3 GUARD MUST BE IN PLACE WHEN OPERATING APPLICATOR IN A BENCH MACHINE.
- 4 LUBRICATE DAILY USING NO. 20 MACHINE OIL.
- 5. ITEMS WITH QTY OF REF SPECIFIED (EXCEPT ITEMS 78 AND 79) ARE USED ON ITEM 32.
- 6 ITEM 78 USED WITH G TERMINATOR ONLY.

| LOC | LEADMAKER | K TERMINATOR BENCH MACHINE | G TERMINATOR BENCH MACHINE |
|------|-----------|----------------------------|----------------------------|
| A | | | |
| DIST | | | |
| 66 | | | |

| QTY | RECD | PER | ASSY | PARTS LIST | DESCRIPTION | ITEM NO |
|-----|------|-----|----------|------------|-------------|---------|
| -2 | -1 | U/M | DWG SIZE | PART NO | DESCRIPTION | ITEM NO |
| | | | | | | |

| QTY RECD PER ASSY | | PARTS LIST | | REVISION OF EACH ASSY NO (WHEN BLANK, USE DWG REVISION) | |
|-------------------|--|------------|--|---|--|
| | | | | | |
| | | | | | |

DIMENSIONS IN INCHES. DO NOT SCALE PRINT. TOLERANCES UNLESS OTHERWISE SPECIFIED:

DR M. OBRINE 5-7-96 APP T. ELBIN 5-7-96
 CHK 5-7-96 REL 7/16/96
 C. ERISMAN B. MORGAN

AMP AMP Incorporated Harrisburg, PA 17105-3608

NAME: END FEED HDM APPLICATOR MACHINE REF: MINI APPL
 SCALE: D DWG NO: 680303 SHEET: 1 OF 1 REV: A1

CUSTOMER AND ASSEMBLY DRAWING