

# SOLENOID PRODUCT SPECIFICATION

PART No.	VOLTAGE	DUTY CYCLE	POWER (W)	CURRENT (A)	DCR (Ω) *
DSOL-0830-05C	5 VDC	100%	6.4	1.3	3.9
DSOL-0830-05E	5 VDC	25%, 60sec On	12.5	2.5	2.0
DSOL-0830-12C	12 VDC	100%	6.4	0.6	22.5
DSOL-0830-12E	12 VDC	25%, 60sec On	12.5	1.1	11.5
DSOL-0830-24C	24 VDC	100%	6.4	0.3	90.0
DSOL-0830-24E	24 VDC	25%, 60sec On	12.5	0.6	46.0

DRAWING SHOWN SOLENOID ENERGIZED

\* Release value are ±10% at 25°C.  
 \* DCR VALUES ARE ±10% AT 25°C

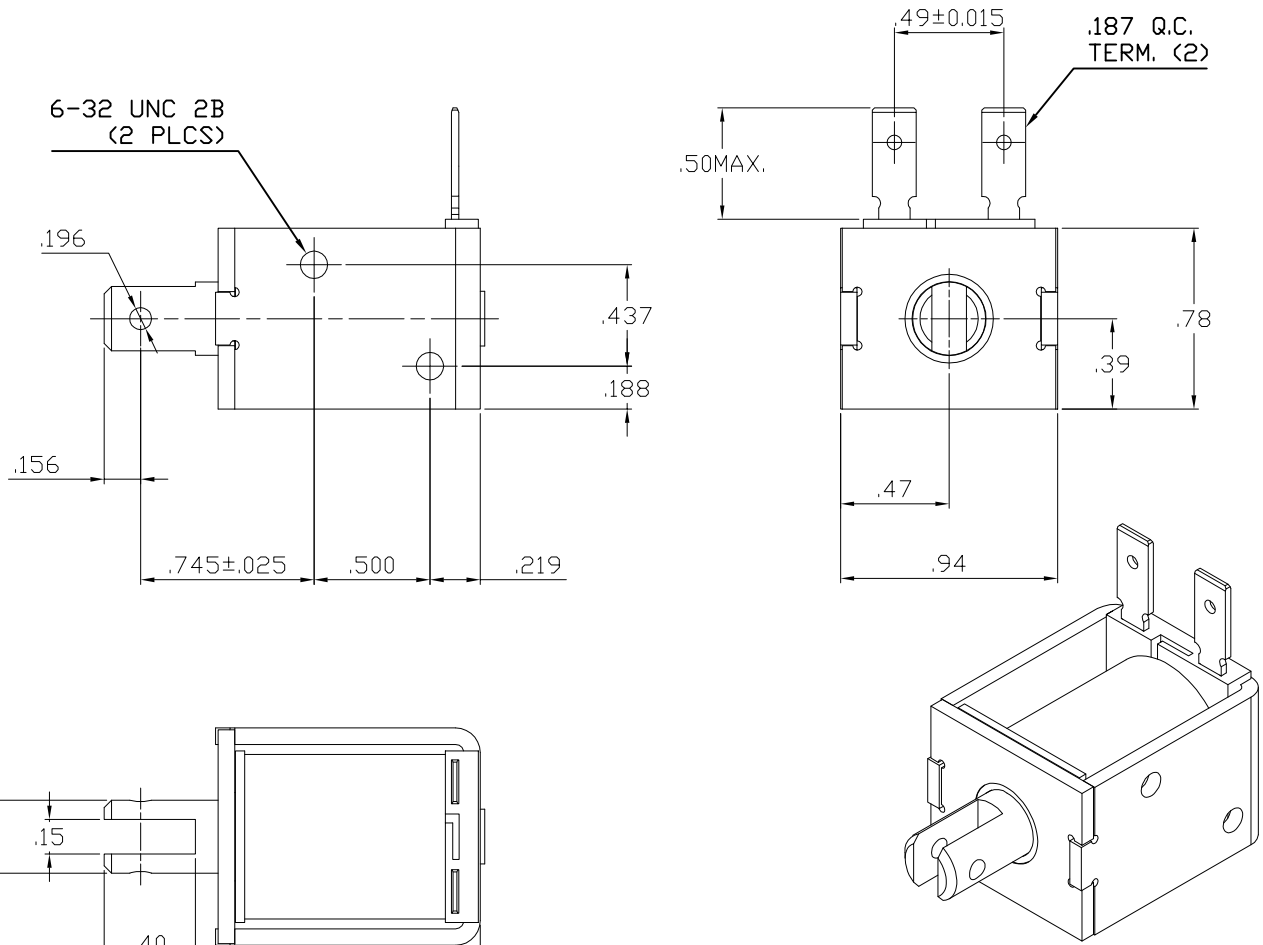

## 2. SCHEMATIC AND CONSTRUCTION :

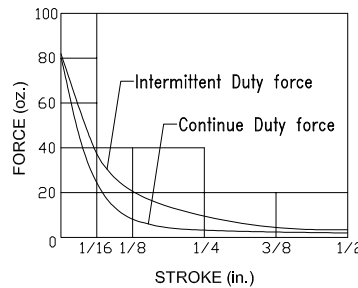
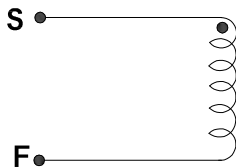

UNIT : inch.

UNLESS TOLERANCES.

X.X = ±0.02

X.XX = ±0.01

ANGLES = ±1°

INSULATION MATERIALS: UL CONSTRUCTION, CLASS B 130°C  
 LIFE EXPECTANCY: 100K CYCLES OPERATIONS

LAYER TEST	IR. @500 Vdc.	HI-POT
(S-F) 500Vp. MIN.	COIL TO FRAME	@50/60Hz., 2mA
TEST ONLY COIL	50 MOHM MIN.	COIL TO FRAME
		1200Vac., 1s