	Date	17-Sep-2022	SPECIFICATION	OLE WOLFF
	Page	1 / 5		www.owolff.com
	CN	P/N: OWPB-3308W-32.5-24		Revision: 00



SPECIFICATION FOR APPROVAL

Piezo Transducer

Part Number	OWPB-3308W-32.5-24
Note	This item was compliance with the following requirements: 1. RoHS directive 2. REACH
Customer P/N	

Ole Wolff	Signature / Date	Prepared	Checked	Approved
		Yaobaoxin 2022.9.17		

Customer	Signature / Date	Confirmation		

REVISION NOTES:

Date	Rev.	Description of Revision
2022.9.17	00	Initial Release

OLE WOLFF ELEKTRONIK A/S Roedengvej 25 4180 Soroe Denmark TEL: +45 57833830 FAX: +45 57820019	OLE WOLFF ELECTRONICS INC. 1525 McCarthy Blvd, Suite 1093 Milpitas, Ca 95035 USA TEL: +1 408 888 8413	OLEWOLFF ELEKTRONIK GmbH Schulstrasse 15A. DE-25451 Quickborn, Germany TEL: +49 (0) 4106 765900 FAX: +49 (0) 4106 627297	OLEWOLFF ELECTRONICS 3 Bedford Street, Woburn, Bedfordshire MK17 9QB, ENGLAND TEL: +44 (0) 1525 290755 FAX: +44 (0) 1525 290855	OLE WOLFF ELEKTRONIK Yliopistonkatu 26 (P.O.BOX 257) FI-40101 Jyväskylä Finland TEL: +358 14 338 3050 FAX: +358 14 338 3059	OLE WOLFF (ASIA) LTD. Unit B, 19/F., Bold Win Ind. Bldg., No. 16-18 Wah Sing St., Kwai Chung, N.T., H.K. TEL: +852 2424 3274 FAX: +852 2424 2219	OLE WOLFF LTD. Unit 7A08, Block 2, Elite Building, Nanshan Avenue, Nanshan District, Shenzhen, PRC. TEL: +86 755 82612542 TEL: +86 755 26406156
---	---	--	--	--	--	---

	Date	17-Sep-2022	SPECIFICATION	OLE WOLFF
	Page	2 / 5		www.owolff.com
	CN	P/N: OWPB-3308W-32.5-24		Revision: 00

1. SCOPE

THIS SPECIFICATION IS APPLIED TO OLE WOLFF PIEZO TRANSDUCER MODEL: OWPB-3308W-32.5-24

2. GENERAL REQUIREMENTS

OPERATING TEMPERATURE RANGE: -20°C ~ +60°C

STORAGE TEMPERATUR RANGE: -30°C ~ +60°C

3. MECHANICAL LAYOUT & DIMENSIONS

DIMENSIONS: SHOWN IN FIGURE 3.

WEIGHT: 3.5g

4. ELECTRICAL CHARACTERISTICS

NO.	ITEM	SPECIFICATION
1	RATED VOLTAGE	24Vp-p
2	MAX INPUT VOLTAGE	30 Vp-p
3	RESONANT FREQUENCY	2750-3500Hz
4	CAPACITANCE AT 120HZ	120000±30%pF
5	*RATED CURRENT	≤80mA
6	* SOUND OUTPUT AT 3 M	≥90dB at 3.25 KHz
8	HOUSING MATERIAL	PBT/ Black

*Applying rated voltage (Resonant frequency, Square wave)

OLE WOLFF ELEKTRONIK A/S Roedengvej 25 4180 Soroe Denmark TEL: +45 57833830 FAX: +45 57820019	OLE WOLFF ELECTRONICS INC. 1525 McCarthy Blvd, Suite 1093 Milpitas, Ca 95035 USA TEL: +1 408 888 8413	OLEWOLFF ELEKTRONIK GmbH Schulstrasse 15A. DE-25451 Quickborn, Germany TEL: +49 (0) 4106 765900 FAX: +49 (0) 4106 627297	OLEWOLFF ELECTRONICS 3 Bedford Street, Woburn, Bedfordshire MK17 9QB, ENGLAND TEL: +44 (0) 1525 290755 FAX: +44 (0) 1525 290855	OLE WOLFF ELEKTRONIK Yliopistonkatu 26 (P.O.BOX 257) FI-40101 Jyväskylä Finland TEL: +358 14 338 3050 FAX: +358 14 338 3059	OLE WOLFF (ASIA) LTD. Unit B, 19/F., Bold Win Ind. Bldg., No. 16-18 Wah Sing St., Kwai Chung, N.T., H.K. TEL: +852 2424 3274 FAX: +852 2424 2219	OLE WOLFF LTD. Unit 7A08, Block 2, Elite Building, Nanshan Avenue, Nanshan District, Shenzhen, PRC. TEL: +86 755 82612542 TEL: +86 755 26406156
---	---	--	--	--	--	---

	Date	17-Sep-2022	SPECIFICATION	OLE WOLFF
	Page	3 / 5		www.owolff.com
	CN	P/N: OWPB-3308W-32.5-24		Revision: 00

5. RELIABILITY TEST

- After Test All specifications must be satisfied after the test.				
5.1 High temperature Test Temperature: +60±2°C Duration: 96HRS				
5.2 Low temperature Test Temperature: -30±2°C Duration: 96HRS				
5.3 Humidity Test Temperature: +40±2°C Humidity: 93(+2/-3)%RH Duration: 96HRS				
5.4 Temperature cycling Test Temperature: -30±2°C room temp. +60±2°C room temp. Duration: 30min 15min 30min 15min Cycle: 5 cycles				
5.5 Vibration Test Input power: 10Hz to 55Hz, and then 55Hz to 10Hz (To-and-fro. sweep time:1 minute) Amplitude: 1.0mm Direction: X, Y and Z (0.5hours per plane)				
5.6 Drop Test Height: 700mm Drop Face: 10mm thick wooden board. Times: 3 times				
5.7 Solder heat resistance Pin terminals are immersed up to 1.5mm from part's body in solder bath of 260±5°C for 10±1s.Refer to GB2423.28.				

OLE WOLFF ELEKTRONIK A/S Roedengvej 25 4180 Soroe Denmark TEL: +45 57833830 FAX: +45 57820019	OLE WOLFF ELECTRONICS INC. 1525 McCarthy Blvd, Suite 1093 Milpitas, Ca 95035 USA TEL: +1 408 888 8413	OLEWOLFF ELEKTRONIK GmbH Schulstrasse 15A. DE-25451 Quickborn, Germany TEL: +49 (0) 4106 765900 FAX: +49 (0) 4106 627297	OLEWOLFF ELECTRONICS 3 Bedford Street, Woburn, Bedfordshire MK17 9QB, ENGLAND TEL: +44 (0) 1525 290755 FAX: +44 (0) 1525 290855	OLE WOLFF ELEKTRONIK Yliopistonkatu 26 (P.O.BOX 257) FI-40101 Jyväskylä Finland TEL: +358 14 338 3050 FAX: +358 14 338 3059	OLE WOLFF (ASIA) LTD. Unit B, 19/F., Bold Win Ind. Bldg., No. 16-18 Wah Sing St., Kwai Chung, N.T., H.K. TEL: +852 2424 3274 FAX: +852 2424 2219	OLE WOLFF LTD. Unit 7A08, Block 2, Elite Building, Nanshan Avenue, Nanshan District, Shenzhen, PRC. TEL: +86 755 82612542 TEL: +86 755 26406156
---	---	--	--	--	--	---

	Date	17-Sep-2022	SPECIFICATION	OLE WOLFF
	Page	4 / 5		www.owolff.com
	CN	P/N: OWPB-3308W-32.5-24		Revision: 00

6. TEST METHOD (Figure 1)

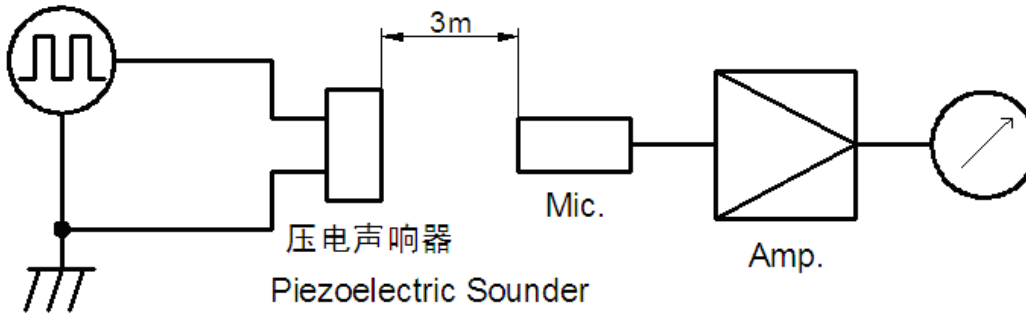

MIC: ND10 普通声级计或等同品
MIC: ND10 Sound Meter or equivalent

信号发生器: DF1641D或等同品
Signal Generator: DF1641D or equivalent

7. FREQUENCY RESPONSE (Figure 2)

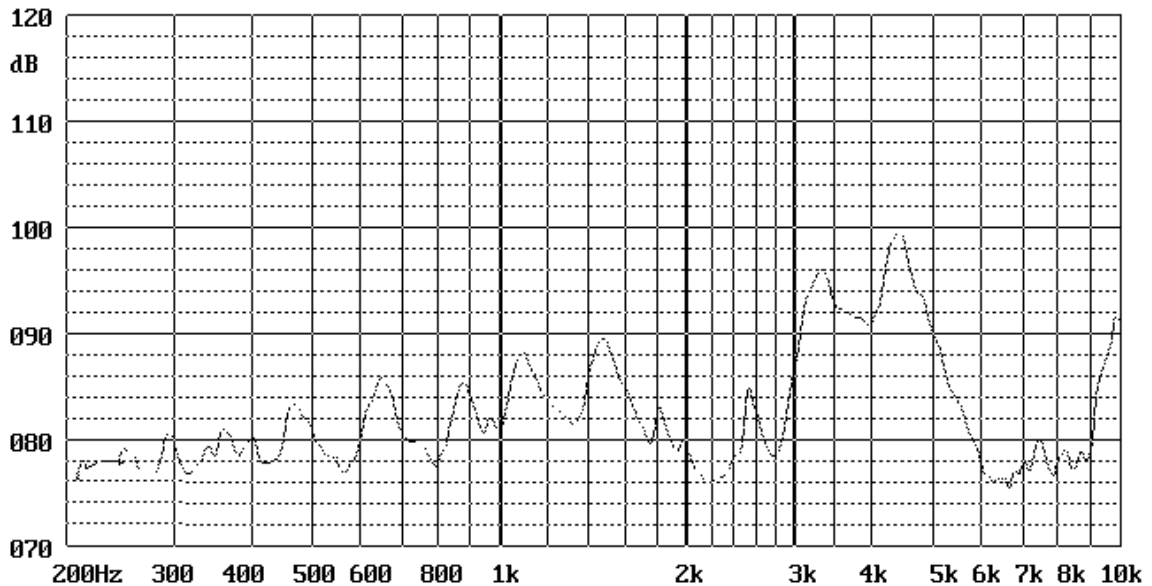

OLE WOLFF ELEKTRONIK A/S Roedengvej 25 4180 Soroe Denmark TEL: +45 57833830 FAX: +45 57820019	OLE WOLFF ELECTRONICS INC. 1525 McCarthy Blvd, Suite 1093 Milpitas, Ca 95035 USA TEL: +1 408 888 8413	OLEWOLFF ELEKTRONIK GmbH Schulstrasse 15A. DE-25451 Quickborn, Germany TEL: +49 (0) 4106 765900 FAX: +49 (0) 4106 627297	OLEWOLFF ELECTRONICS 3 Bedford Street, Woburn, Bedfordshire MK17 9QB, ENGLAND TEL: +44 (0) 1525 290755 FAX: +44 (0) 1525 290855	OLE WOLFF ELEKTRONIK Yliopistonkatu 26 (P.O.BOX 257) FI-40101 Jyväskylä Finland TEL: +358 14 338 3050 FAX: +358 14 338 3059	OLE WOLFF (ASIA) LTD. Unit B, 19/F., Bold Win Ind. Bldg., No. 16-18 Wah Sing St., Kwai Chung, N.T., H.K. TEL: +852 2424 3274 FAX: +852 2424 2219	OLE WOLFF LTD. Unit 7A08, Block 2, Elite Building, Nanshan Avenue, Nanshan District, Shenzhen, PRC. TEL: +86 755 82612542 TEL: +86 755 26406156
---	---	--	--	--	--	---

	Date	17-Sep-2022	SPECIFICATION	OLE WOLFF
	Page	5 / 5		www.owolff.com
	CN	P/N: OWPB-3308W-32.5-24		Revision: 00

8. DIMENSIONS (Figure 3)

Unit: mm Tolerance: ±0.5mm Except Specified

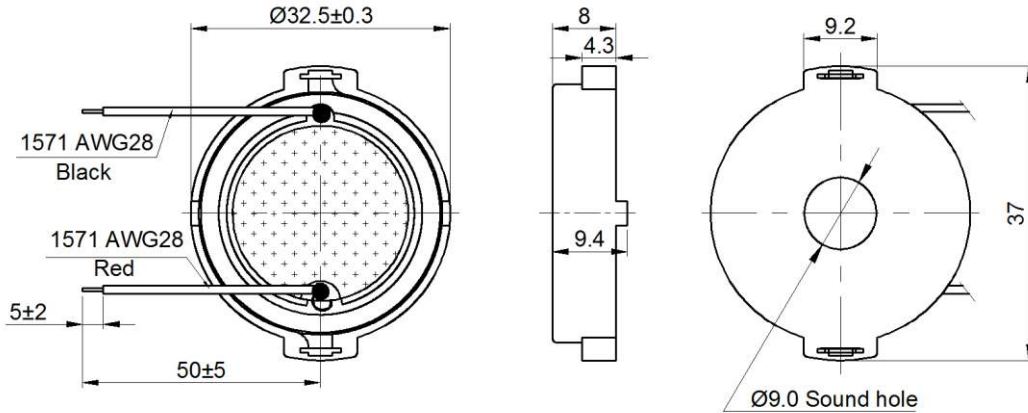

9. PACKAGE INFORMATION

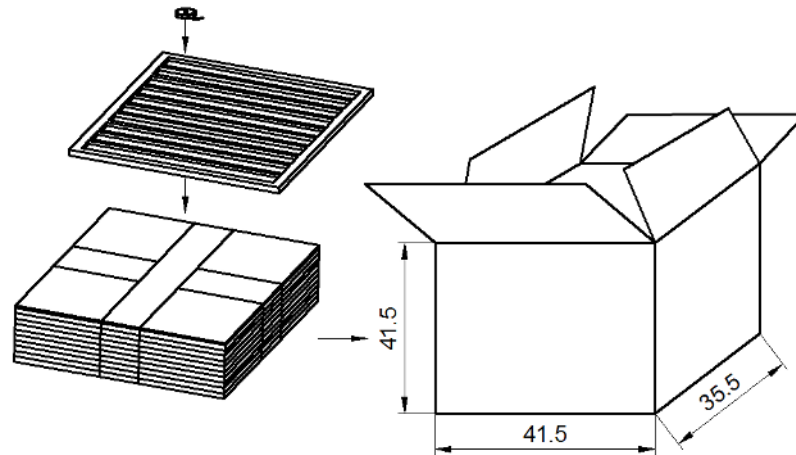

NOTES:

- 1.80PCS per plate
- 2.Total 30 plates per carton
- 3.Total 2400PCS a carton
- 4.Volume:41.5*35.5*41.5cm

OLE WOLFF ELEKTRONIK A/S Roedengvej 25 4180 Soroe Denmark TEL: +45 57833830 FAX: +45 57820019	OLE WOLFF ELECTRONICS INC. 1525 McCarthy Blvd, Suite 1093 Milpitas, Ca 95035 USA TEL : +1 408 888 8413	OLEWOLFF ELEKTRONIK GmbH Schulstrasse 15A. DE-25451 Quickborn, Germany TEL: +49 (0) 4106 765900 FAX: +49 (0) 4106 627297	OLEWOLFF ELECTRONICS 3 Bedford Street, Woburn, Bedfordshire MK17 9QB, ENGLAND TEL: +44 (0) 1525 290755 FAX: +44 (0) 1525 290855	OLE WOLFF ELEKTRONIK Yliopistonkatu 26 (P.O.BOX 257) FI-40101 Jyväskylä Finland TEL: +358 14 338 3050 FAX: +358 14 338 3059	OLE WOLFF (ASIA) LTD. Unit B, 19/F., Bold Win Ind. Bldg., No. 16-18 Wah Sing St., Kwai Chung, N.T., H.K. TEL: +852 2424 3274 FAX: +852 2424 2219	OLE WOLFF LTD. Unit 7A08, Block 2, Elite Building, Nanshan Avenue, Nanshan District, Shenzhen, PRC. TEL: +86 755 82612542 TEL: +86 755 26406156
---	--	--	--	--	--	---