

THIS DRAWING IS UNPUBLISHED. RELEASED FOR PUBLICATION
 © COPYRIGHT - ALL RIGHTS RESERVED.

LOC	DIST	REVISIONS					
		P	LTR	DESCRIPTION	DATE	DWN	APVD
B1	-		D3	REVISED PER ECO-11-005150	31MAR2011	RK	HMR
			D4	ECR-14-007793	26AUG2014	RK	MKO
			D5	REVISED PER ECR-16-016780	19AUG2017	NG	MKO
			D6	REVISED PER ECR-21-123503	12MAR2022	RK	JB

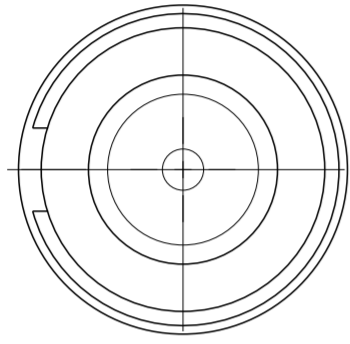

WIRE CROSS-SECTION:
 $\varnothing 6\text{mm}^2 - 16\text{mm}^2$

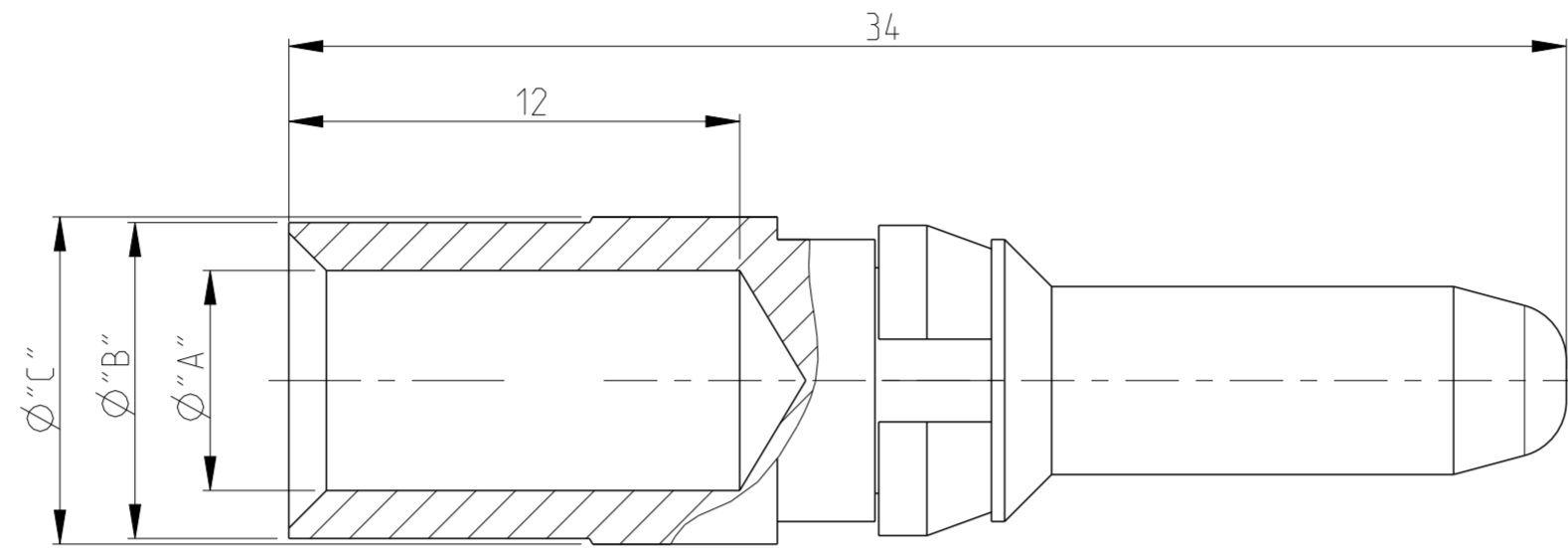

WIRE CROSS-SECTION:
 $\varnothing 2.5\text{mm}^2 / 4\text{mm}^2$

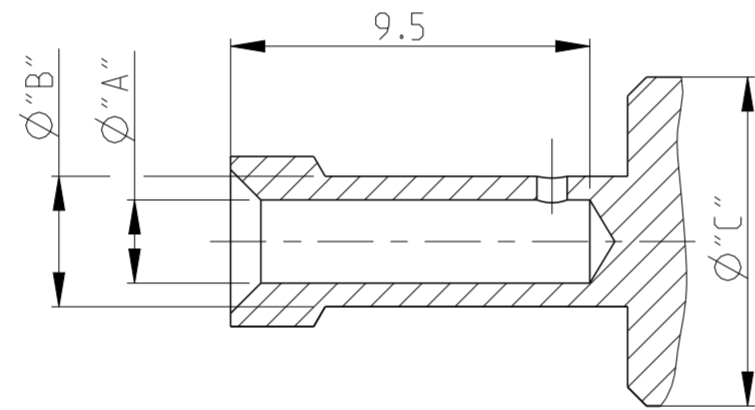

Notes

- 1 MATERIAL: BRASS
- 2 FINISH SILVER PLATING: 2 μm Ag MIN. OVER Cu
- 3 FINISH GOLD PLATING: 0.75 μm Au MIN. OVER Ni
- 4 WEIGHT (MAX.): 7.60 g, VOLUME (MAX.): 932mm³ (APPROX.)
- 5 SUITABLE SOCKET CONTACT: CUSTOMER DRAWING 1105151
- 6 SUITABLE INSERTS: SERIES HSS, CUSTOMER DRAWING
- 7 SUITABLE CRIMP TOOL: PN 1-1105850-8
- 8 SUITABLE INSERTION TOOL: -
- 9 SUITABLE EXTRACTION TOOL: PN 0-1102855-5
- 10 FINE WIRE DIA. MAX. $\varnothing 4.5$
- 11 PACKAGING:
25 PIECES IN A POLY-BAG
1 POLY-BAG IN A CARTON
- 12 PACKAGING:
1 PIECES LOOSE
- 13 STANDARDS: DIN EN 61984, DIN EN 60664-1

OBSOLETE	HSS-C-Sti.Au.16.0 mm ²	GOLD	11	12				11	12		
			5-2	9-3	16.0	5.85	8.4	8.7	12	5-2	9-3
	HSS-C-Sti.Au.10.0 mm ²		4-2	9-2	10.0	4.35	5.9	8.7	12	4-2	9-2
	HSS-C-Sti.Au.6.0 mm ²		3-2	9-1	6.0	3.5	4.9	8.7	12	3-2	9-1
	HSS-C-Sti.Ag.25.0 mm ²	SILVER	6-1	8-7	25.0	7	9.45	9.6	12	6-1	8-7
	HSS-C-Sti.Ag.16.0 mm ²		5-1	8-6	16.0	5.85	8.4	8.7	12	5-1	8-6
	HSS-C-Sti.Ag.10.0 mm ² -fine		4-3	8-5	10.0	4.6	5.9	8.7	12	4-3	8-5
	HSS-C-Sti.Ag.10.0 mm ²		4-1	8-4	10.0	4.35	5.9	8.7	12	4-1	8-4
	HSS-C-Sti.Ag.6.0 mm ²		3-1	8-3	6.0	3.5	4.9	8.7	12	3-1	8-3
	HSS-C-Sti.Ag.4.0 mm ²		2-1	8-2	4.0	2.8	3.9	8.7	12	2-1	8-2
	HSS-C-Sti.Ag.2.5 mm ²		1-1	8-1	2.5	2.2	3.45	8.7	12	1-1	8-1
						[MM ²]	"A"	"B"	"C"	[MM]	PN
	ORDERING TEXT	PLATING	CROSS SECTION	DIMENSIONS	STRIPPING-LENGTH	WITH CLIP					

PARTS LIST

THIS DRAWING IS A CONTROLLED DOCUMENT. DWN: 08APRIL2008 K.SCHROEDER
 CHK: H.BRAUN
 APVD: T.SCHNURPFEIL

STE TE Connectivity

PIN CONTACT SERIES HSS

108-74016
 114-74028

SIZE: A2 CAGE CODE: 00779 DRAWING NO: 1105150 RESTRICTED TO: -
 WEIGHT: - SCALE: 5:1 SHEET 1 OF 1 REV: 06
 Customer Drawing

