

RF CHARACTERISTICS

Frequency range : **0 - 40 GHz**
Impedance : **50 Ohms**

Frequency (GHz)	DC - 6	6 - 12.4	12.4 - 18	18 - 26.5	26.5 - 40
VSWR max	1.30	1.40	1.50	1.70	1.90
Insertion loss max	0.30 dB	0.40 dB	0.50 dB	0.70 dB	0.80 dB
Isolation min	70 dB	60 dB	60 dB	55 dB	50 dB
Average power (*)	80 W	60 W	50 W	20 W	10 W

ELECTRICAL CHARACTERISTICS

Actuator : **LATCHING**
Nominal current ** : **320 mA**
Actuator voltage (Vcc) : **12V (10.2 to 13V)**
Terminals : **9 pins D-SUB male connector**
Indicator rating : **1 W / 30 V / 100 mA**
Self cut-off time : **40 ms < CT < 120 ms**
TTL inputs (E) - High level : **2.2 to 5.5 V / 800µA at 5.5 V**
- Low level : **0 to 0.8 V / 20µA at 0.8 V**

MECHANICAL CHARACTERISTICS

Connectors : **SMA 2.9 female per MIL-C 39012**
Life : **2.5 million cycles**
Switching Time*** : **< 15 ms**
Construction : **Splashproof**
Weight : **< 100 g**

ENVIRONMENTAL CHARACTERISTICS

Operating temperature range : **-40°C to +85°C**
Storage temperature range : **-55°C to +85°C**

(* Average power at 25°C per RF Path)

(** At 25° C ±10%)

(*** Nominal voltage ; 25° C)



PAGE 2/2

ISSUE 25-10-16

SERIE : DPDT

PART NUMBER : R577862105

DRAWING

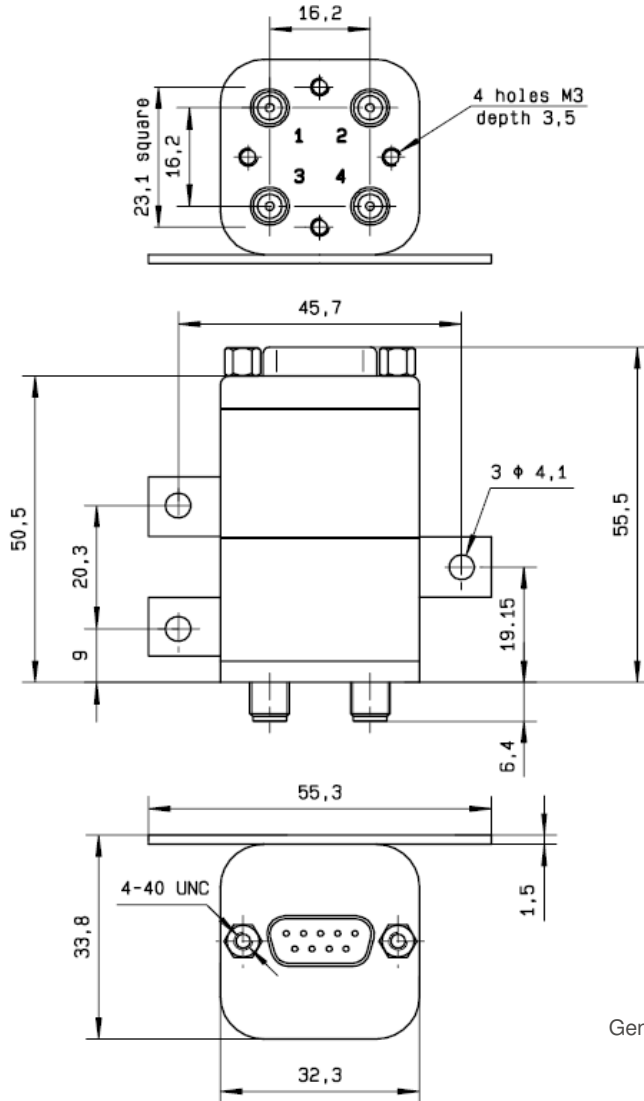

LABEL

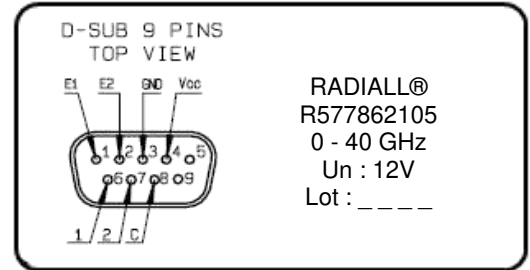

General tolerances : ±0.5 mm

SCHEMATIC DIAGRAM

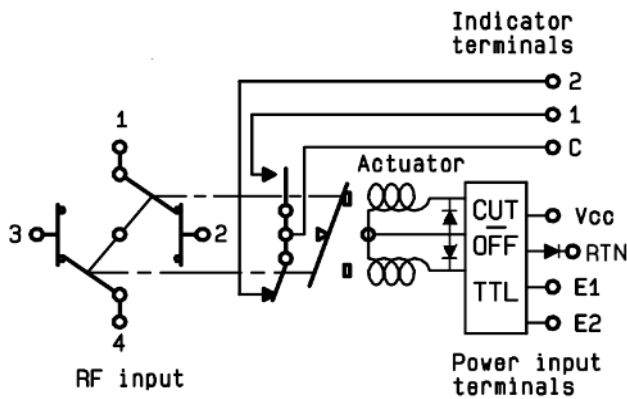

TTL input	RF Continuity	Ind.
E1=1 / E2=0	1 ↔ 3 / 2 ↔ 4	C.1
E1=0 / E2=1	1 ↔ 2 / 3 ↔ 4	C.2
E1=0 / E2=0	Memory	-
E1=1 / E2=1	Forbidden	-