

PART NUMBER	REVISION	DESCRIPTION	FEED TYPE
2150611-2	B	FINE CRIMP HEIGHT ADJUST	PNEUMATIC
7-2150611-2	B	PNEUMATIC AND CRIMP TOOLING KIT	PNEUMATIC
7-2150611-7	A	CRIMP TOOLING KIT	-

ATLANTIC VERSION TERMINATOR INTERFACE ADAPTER

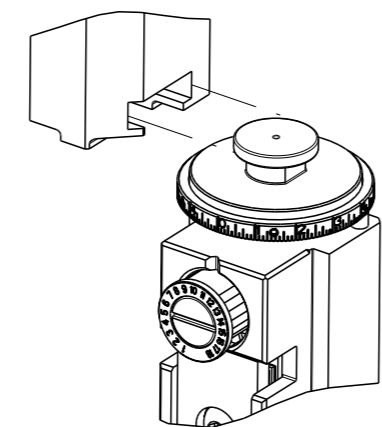

APPLICATOR DATA		
CRIMP	SIZE	TYPE
WIRE	3.05 mm [.120]	F
INSUL	4.50 mm [.177]	F
APPL INSTRUCTIONS 408-35043		

TERMINAL DATA: YAZAKI TERMINAL YAZAKI CRIMP SPECIFICATION			
TERMINAL NAME: TERMIANL			
WIRE STRIP LENGTH		INSULATION DIAMETER RANGE	
4.50-5.50 mm [.177-.217 IN]		∅2.20-3.40 mm [.087-.134 IN]	
TERMINAL APPLICATION SPECIFICATION		7113-1020 Rev WA2235	
TERMINALS APPLIED			
TE TERMINAL	YAZAKI TERMINAL	TE TERMINAL	YAZAKI TERMINAL
286777-1	7113-1020		

WIRE SIZE	CRIMP HEIGHT mm [INCH]	CRIMP HEIGHT REFERENCE SETTING
AV 2mm ² or GXL 14 AWG	1.80+/-0.05 [.071+/- .002]	3.5
AV 1.25mm ² or GXL 16 AWG	1.60+/-0.05 [.063+/- .002]	5.7
AV 0.85mm ² or GXL 18 AWG	1.40+/-0.05 [.055+/- .002]	7.8
AV 0.5mm ² or GXL 20 AWG	1.30+/-0.05 [.051+/- .002]	9.0

- RECOMMENDED SPARE PARTS
- REFER TO SUPPLIED INSTRUCTION SHEET FOR CLEANING, LUBRICATION AND STORAGE OF APPLICATOR.
- APPLY PART NUMBER 1-23419-5 LOCTITE TO THREADS OF ITEMS 180. APPLY PART NUMBER 2-23419-6 LOCTITE TO THREADS OF ITEM 242.
- CRIMP HEIGHT REFERENCE SETTING WAS THE SETTING USED WHEN THE APPLICATOR WAS QUALIFIED AT THE FACTORY. ADJUSTMENT MAY BE NECESSARY WHEN RUNNING APPLICATOR IN THE FIELD.
- TERMINAL LUBRICANT IS RECOMMENDED.
- TERMINAL PITCH NOT COMPATIBLE WITH MECHANICAL FEED.
- 7. UNLESS SPECIFIED OTHERWISE TORQUE VALUES SHALL BE USED PER DOCUMENT, 101-35000.

***WARNING**
ON INSTALLATION, SET WIRE DISC TO CRIMP HEIGHT REFERENCE SETTING FOR LARGEST WIRE SIZE. CRIMP HEIGHT REFERENCE SETTINGS GREATER THAN THE VALUE SHOWN MAY CAUSE DAMAGE TO THE CRIMP TOOLING, REFER TO THE INSTRUCTION SHEET FOR PROPER SETUP AND ADJUSTMENTS.

ATLANTIC VERSION
Shown on sheets 1 of 4 & 2 of 4
(Pacific version shown on sheets 3 of 4 & 4 of 4)

LOC	DIST	REVISIONS					
		P	LY#	DESCRIPTION	DATE	OWN	APVD
A	66	1		DEVELOPMENT	17AUG2015	YY	UG
		A		RELEASED	24SEP2015	YY	UG
		A1		ECR-18-004524	26MAR2018	JAH	TE
		B		ECR-20-012915	15SEP2020	FJ	TE

-	1	1	1803203-1	BLOCK, FRONT DEPRESSOR	261		
-	1	1	2119641-1	FEED CAM, AIR FEED	248		
-	1	1	2119082-3	CAM, SNAIL, INSULATION ADJUSTMENT	244		
-	1	1	2079764-1	WASHER, WAVE SPRING, CREST-TO-CREST	243		
	1	1	2119083-1	RETAINER, INSULATION DIAL	242		
-	1	1	2844940-4	AIR FEED MODULE	238		
	1	1	2-1976055-3	STANDOFF, HOLD-DOWN	180		
-	1	1	6-993111-6	PIN, SLOTTED SPRING 3.0 X 14.0	177		
-	1	1	8-22280-7	SPRING, COMPRESSION	176		
-	1	1	1752353-2	GUIDE PIN, HOLDDOWN	175		
-	1	1	1901680-2	GUIDE PIN, HOLDDOWN	174		
-	REF	REF	994970-2	COUNTER, MAGNETIC	164		
	1	1	2119955-2	ASSY, LUBRICATOR, END FEED	84		
-	1	1	455888-8	SPACER, CRIMPER	82		
-	1	1	2119791-5	DEPRESSOR, WIRE	73		
-	1	1	1803607-4	DOCUMENTATION PACKAGE	71		
-	2	2	2-18032-2	SCR, SET, FLT PNT, M3 X 10.0	70		
-	1	1	2119740-1	TAG, IDENTIFICATION	67		
-	2	2	2168078-1	SCREW, DRIVE, RH, RoHS, 2 x .188	66		
-	1	1	1901681-5	HOLDDOWN, TERMINAL	65		
-	2	2	2168400-5	SHCS, LOW HEAD, RoHS, M4 X 20	64		
-	1	1	2168083-2	SCR, SKT HD CAP, RoHS, M4 X 8.0	60		
-	1	1	5-18022-5	SCR, HEX HD CAP, M4 X 6.0	59		
-	3	3	2168400-4	SHCS, LOW HEAD, RoHS, M4 X 8	57		
-	2	2	1-2168083-0	SCR, SKT HD CAP, RoHS, M4 X 10	56		
-	2	2	5018030-1	NUT, HEX, REG, RoHS, M3	54		
-	2	2	986965-8	NUT, LOCK, HEX, TORQUE (M4)	53		
-	1	1	1-5018030-0	NUT, HEX, REG, RoHS, M3.5	52		
-	1	1	2063961-9	FEED FINGER	51		
-	1	1	18023-9	SCR, SKT HD CAP M4 X 6.0	49		
-	1	1	2119655-5	APPLICATOR BASIC ASSEMBLY, EF	46		
-	1	1	1803517-1	RAM ASSEMBLY, EF ATLANTIC	44		
-	1	1	1803602-1	SCR, BHSC, RoHS (M8 X 25)	41		
-	7	7	1-18028-2	WASHER, FLAT, REG M4	33		
-	2	2	2168083-9	SCR, SKT HD CAP, RoHS, M4 X 20	31		
-	2	2	2168083-2	SCR, SKT HD CAP, RoHS, M4 X 8.0	29		
-	1	1	240639-1	STRIPPER (MACHINING)	27		
-	2	2	1-2168083-5	SCR, SKT HD CAP, RoHS, M4 X 30	25		
-	1	1	1752371-5	PLATE, STRIP GUIDE	24		
-	1	1	240825-2	PLATE, STRIP HOLD DOWN	23		
-	2	2	2-22281-3	SPRING, COMPRESSION	22		
-	1	1	1803292-4	DRAG	20		
-	2	2	1901259-6	GUIDE, LOWER STRIP	18		
-	4	4	1-2079383-1	SCR, BHSC, RoHS (M6 X 12)	17		
	1	1	240644-1	PLATE, REAR SHEAR	11		
-	-	-	-	-	10		
	1	1	690482-3	PLATE, FRONT SHEAR	9		
	1	2	1803257-4	ANVIL, COMBINATION, END FEED	8		
	1	1	1-2217206-4	BLADE, SLUG	7		
-	-	-	-	-	6		
-	1	1	240641-4	SPACER	5		
-	1	1	238011-1	BLOCK, CRIMPER SPACER	4		
	1	2	4-1633962-4	CRIMPER, INSULATION F PREMIUM	3		
-	1	1	455888-3	SPACER, CRIMPER	2		
	1	2	2-456409-6	CRIMPER, WIRE .120 "F" PREMIUM	1		
-	77-72	-	2	PART NO			
-				DESCRIPTION			ITEM NO

<small>THIS DRAWING IS UNPUBLISHED. IT IS SUBJECT TO CHANGE AND THE CONTROLLER'S RESERVATIONS. DIMENSIONS SHOULD BE CONTACTED FOR THE LATEST REVISION.</small>		DWN Y. YIN 17AUG2015 CHK G. BAILEY 17AUG2015 APVD U. GUO 17AUG2015	TE Connectivity Harrisburg, PA 17105-3608
DIMENSIONS: mm 		TOLERANCES UNLESS OTHERWISE SPECIFIED: 0 PLC ± 1 PLC ± 2 PLC ± 3 PLC ± 4 PLC ± ANGLES FINISH ±	NAME Ocean End Feed Applicator SIZE CAGE CODE DRAWING NO RESTRICTED TO A1 00779 C=2150611 WEIGHT - SCALE 1:1 SHEET 1 OF 4 REV B
MATERIAL:		APPLICATION SPEC:	Customer Accessible Production Drawing

LOC		DIST		REVISIONS			
A	66	P	LYR	DESCRIPTION	DATE	OWN	APVD
		-		SEE SHEET 1			

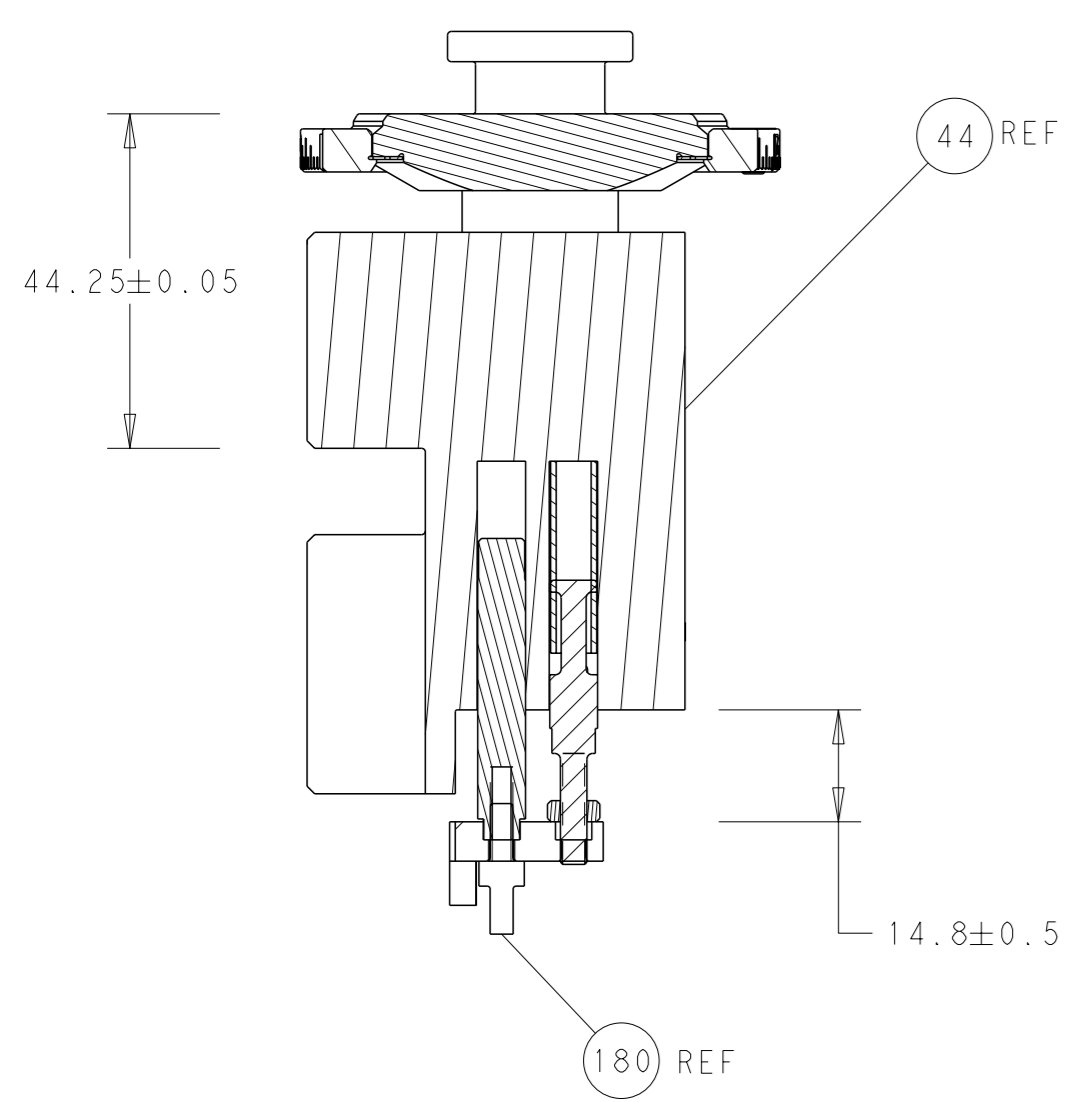

RAM AND HOLDDOWN SET-UP

FEED TYPE

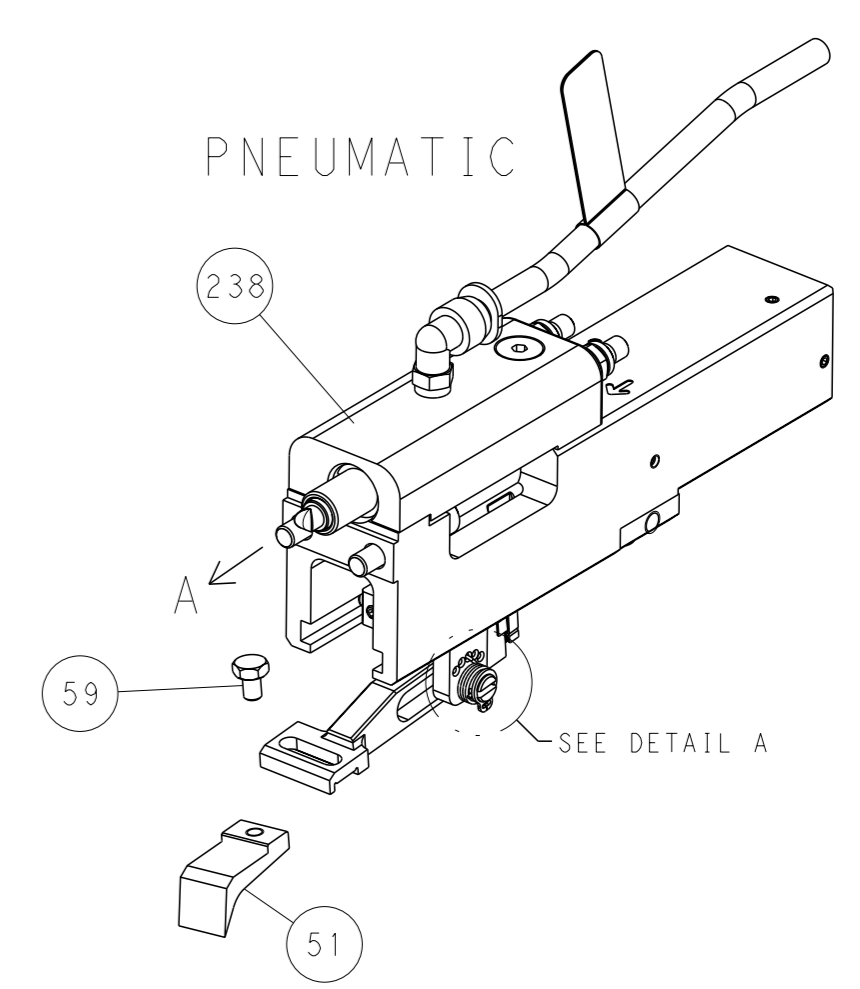

FEED SPRING SETTING POSITION

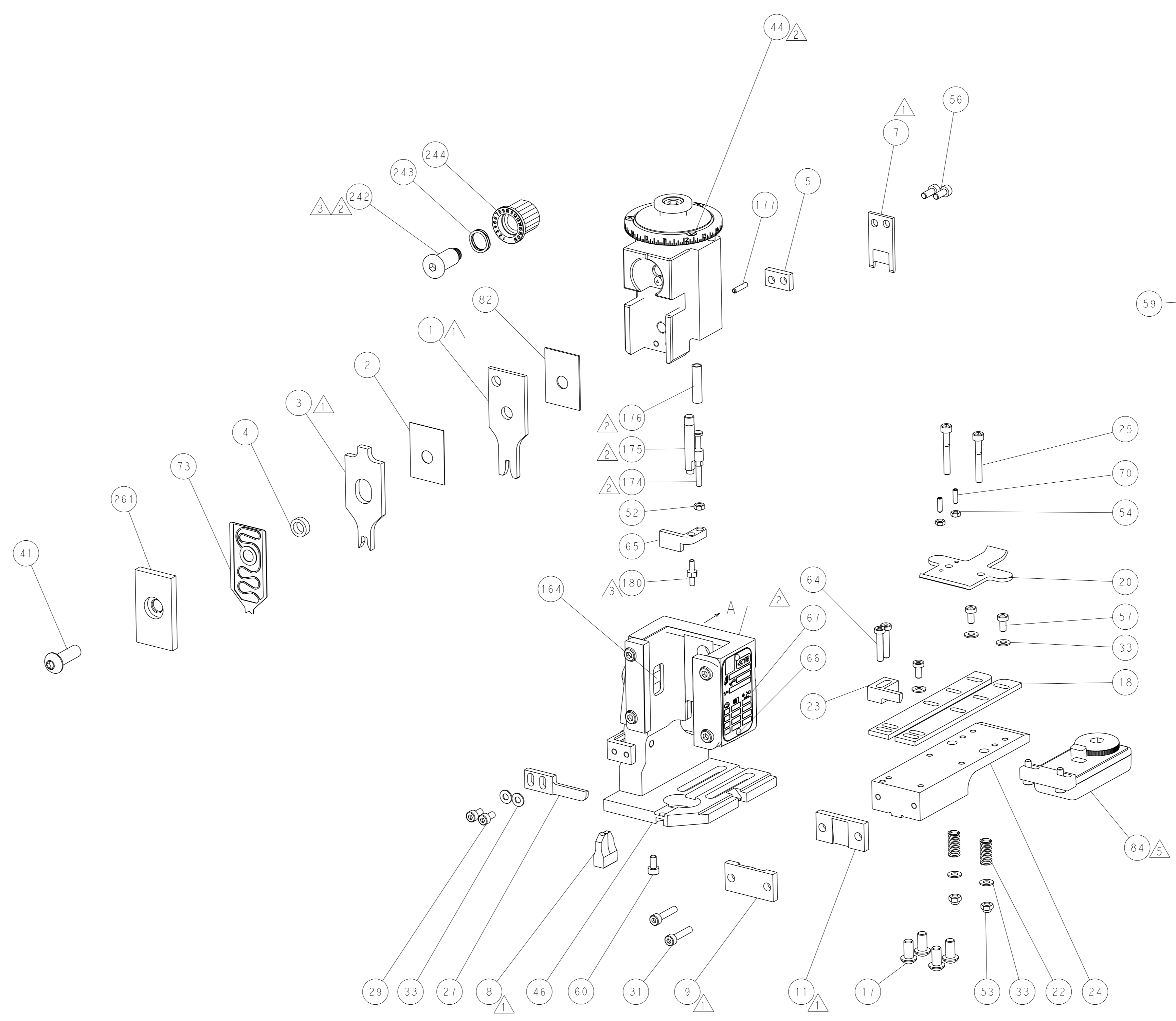
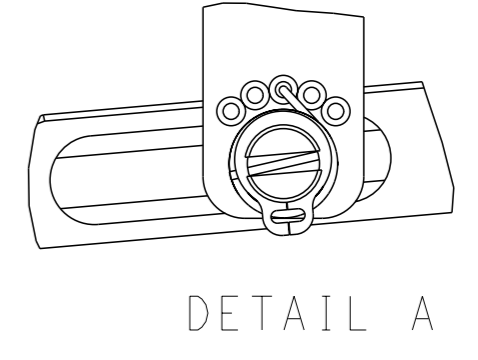

CAM POSITION

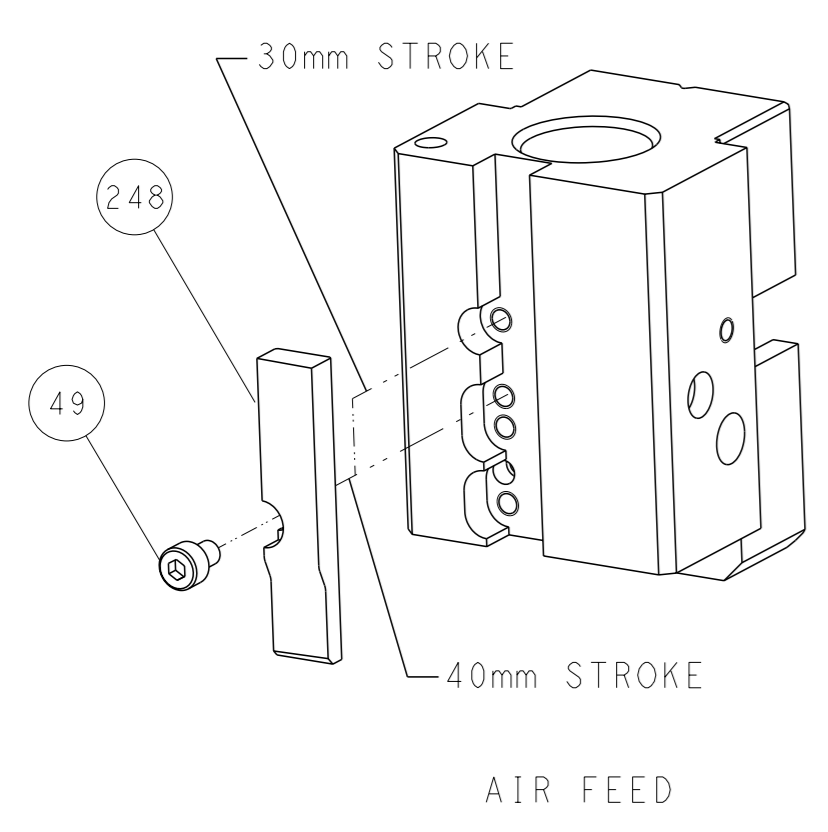

AIR FEED

ATLANTIC VERSION
 Shown on sheets 1 of 4 & 2 of 4
 (Pacific version shown on sheets 3 of 4 & 4 of 4)

<small>THIS DRAWING IS A CONTROLLED DOCUMENT FOR TYCO ELECTRONICS CORPORATION. IT IS SUBJECT TO CHANGE AND TO PATENT AND RESTRICTION DESIGNATION. SHOULD BE CONTACTED FOR THE LATEST VERSION.</small>		OWN: Y. YIN 17AUG2015 CHK: G. BAILEY 17AUG2015 APVD: H. GUO 17AUG2015	TE Connectivity Harrisburg, PA 17105-3608
DIMENSIONS: mm TOLERANCES UNLESS OTHERWISE SPECIFIED: 0 PLC ± 1 PLC ± 2 PLC ± 3 PLC ± 4 PLC ± ANGLES FINISH ±		NAME: Ocean End Feed Applicator SIZE: A1 CAGE CODE: 00779 DRAWING NO: 2150611	RESTRICTED TO: - SCALE: 1:1 SHEET: 2 of 4 REV: B
MATERIAL: - FINISH: -		WEIGHT: - Customer Accessible Production Drawing	SHEETS 3 & 4 ARE NOT REQUIRED FOR ATLANTIC VERSION

THIS DRAWING IS UNPUBLISHED.	RELEASED FOR PUBLICATION		
© COPYRIGHT 20 BY TYCO ELECTRONICS CORPORATION. ALL RIGHTS RESERVED.	20		
PART NUMBER	REVISION	DESCRIPTION	FEED TYPE
2-2150611-2	B	FINE CRIMP HEIGHT ADJUST	PNEUMATIC
7-2150611-7	A	CRIMP TOOLING KIT	-

PACIFIC VERSION TERMINATOR
INTERFACE ADAPTER

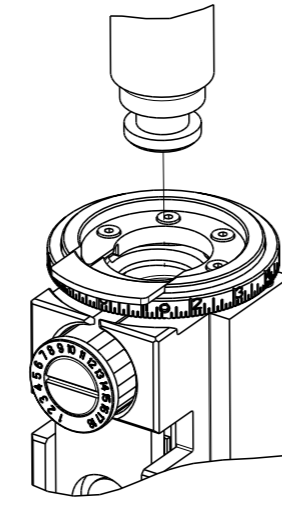

APPLICATOR DATA		
CRIMP	SIZE	TYPE
WIRE	3.05 mm [.120]	F
INSUL	4.50 mm [.177]	F
APPL INSTRUCTIONS 408-35043		

TERMINAL DATA: YAZAKI TERMINAL YAZAKI CRIMP SPECIFICATION			
TERMINAL NAME: TERMIANL			
WIRE STRIP LENGTH		INSULATION DIAMETER RANGE	
4.50-5.50 mm [.177-.217 IN]		2.20-3.40 mm [.087-.134 IN]	
TERMINAL APPLICATION SPECIFICATION	7113-1020 Rev WA2235	-	-
TERMINALS APPLIED			
TE TERMINAL	YAZAKI TERMINAL	TE TERMINAL	YAZAKI TERMINAL
286777-1	7113-1020		

WIRE SIZE	CRIMP HEIGHT mm [INCH]	CRIMP HEIGHT REFERENCE SETTING
AV 2mm ² or GXL 14 AWG	1.80+/-0.05 [.071+/-0.002]	3.5
AV 1.25mm ² or GXL 16 AWG	1.60+/-0.05 [.063+/-0.002]	5.7
AV 0.85mm ² or GXL 18 AWG	1.40+/-0.05 [.055+/-0.002]	7.8
AV 0.5mm ² or GXL 20 AWG	1.30+/-0.05 [.051+/-0.002]	9.0

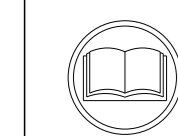

- RECOMMENDED SPARE PARTS
- REFER TO SUPPLIED INSTRUCTION SHEET FOR CLEANING, LUBRICATION AND STORAGE OF APPLICATOR.
- APPLY PART NUMBER 1-23419-5 LOCTITE TO THREADS OF ITEMS 180. APPLY PART NUMBER 2-23419-6 LOCTITE TO THREADS OF ITEM 242.
- CRIMP HEIGHT REFERENCE SETTING WAS THE SETTING USED WHEN THE APPLICATOR WAS QUALIFIED AT THE FACTORY. ADJUSTMENT MAY BE NECESSARY WHEN RUNNING APPLICATOR IN THE FIELD.
- TERMINAL LUBRICANT IS RECOMMENDED.
- TERMINAL PITCH NOT COMPATIBLE WITH MECHANICAL FEED.
- 7. UNLESS SPECIFIED OTHERWISE TORQUE VALUES SHALL BE USED PER DOCUMENT, 101-35000.

***WARNING**
ON INSTALLATION, SET WIRE DISC TO CRIMP HEIGHT REFERENCE SETTING FOR LARGEST WIRE SIZE. CRIMP HEIGHT REFERENCE SETTINGS GREATER THAN THE VALUE SHOWN MAY CAUSE DAMAGE TO THE CRIMP TOOLING, REFER TO THE INSTRUCTION SHEET FOR PROPER SETUP AND ADJUSTMENTS.

PACIFIC VERSION
Shown on sheets 3 of 4 & 4 of 4
(Atlantic version shown on sheets 1 of 4 & 2 of 4)

LOC	DIST	REVISIONS					
A	66	P	LYR	DESCRIPTION	DATE	OWN	APVD
		-		SEE SHEET 1	-	-	-

-	1	1803203-1	BLOCK, FRONT DEPRESSOR	261	
-	1	2119082-3	CAM, SNAIL, INSULATION ADJUSTMENT	244	
-	1	2079764-1	WASHER, WAVE SPRING, CREST-TO-CREST	243	
	-	1	2119083-1	RETAINER, INSULATION DIAL	242
-	1	2844940-4	AIR FEED MODULE	238	
-	4	2079383-9	SCR, BHSC, RoHS (M6 X 20)	186	
	-	1	2-1976055-3	STANDOFF, HOLD-DOWN	180
-	1	6-993111-6	PIN, SLOTTED SPRING 3.0 X 14.0	177	
-	1	8-22280-7	SPRING, COMPRESSION	176	
-	1	1752353-2	GUIDE PIN, HOLDDOWN	175	
-	1	1901680-2	GUIDE PIN, HOLDDOWN	174	
-	REF	994970-2	COUNTER, MAGNETIC	164	
-	1	2119641-2	FEED CAM, AIR FEED	152	
-	1	2168083-8	SCR, SKT HD CAP, RoHS, M4 X 16	144	
-	1	2119655-6	APPLICATOR BASIC ASSEMBLY, EF	141	
-	1	1803518-1	RAM ASSEMBLY, EF PACIFIC	140	
	-	1	2119955-2	ASSY, LUBRICATOR, END FEED	84
-	1	455888-8	SPACER, CRIMPER	82	
-	1	2119791-5	DEPRESSOR, WIRE	73	
-	1	1803607-4	DOCUMENTATION PACKAGE	71	
-	2	2-18032-2	SCR, SET, FLT PNT, M3 X 10.0	70	
-	1	2119740-1	TAG, IDENTIFICATION	67	
-	2	2168078-1	SCREW, DRIVE, RH, RoHS, 2 x .188	66	
-	1	1901681-5	HOLDDOWN, TERMINAL	65	
-	2	2168400-5	SHCS, LOW HEAD, RoHS, M4 X 20	64	
-	1	5-18022-5	SCR, HEX HD CAP, M4 X 6.0	59	
-	3	2168400-4	SHCS, LOW HEAD, RoHS, M4 X 8	57	
-	2	1-2168083-0	SCR, SKT HD CAP, RoHS, M4 X 10	56	
-	2	5018030-1	NUT, HEX, REG, RoHS, M3	54	
-	2	986965-8	NUT, LOCK, HEX, TORQUE (M4)	53	
-	1	1-5018030-0	NUT, HEX, REG, RoHS, M3.5	52	
-	1	2063961-9	FEED FINGER	51	
-	1	18023-9	SCR, SKT HD CAP M4 X 6.0	49	
-	1	1803602-1	SCR, BHSC, RoHS (M8 X 25)	41	
-	7	1-18028-2	WASHER, FLAT, REG M4	33	
-	2	2168083-9	SCR, SKT HD CAP, RoHS, M4 X 20	31	
-	2	2168083-2	SCR, SKT HD CAP, RoHS, M4 X 8.0	29	
-	1	240639-1	STRIPPER (MACHINING)	27	
-	2	1-2168083-5	SCR, SKT HD CAP, RoHS, M4 X 30	25	
-	1	1752371-5	PLATE, STRIP GUIDE	24	
-	1	240825-2	PLATE, STRIP HOLD DOWN	23	
-	2	2-22281-3	SPRING, COMPRESSION	22	
-	1	1803292-4	DRAG	20	
-	2	1901259-6	GUIDE, LOWER STRIP	18	
	-	1	240644-1	PLATE, REAR SHEAR	11
-	-	-	-	10	
	-	1	690482-3	PLATE, FRONT SHEAR	9
	1	1	1803257-4	ANVIL, COMBINATION, END FEED	8
	-	1	1-2217206-4	BLADE, SLUG	7
-	-	-	-	6	
-	1	1	240641-4	SPACER	5
-	1	1	238011-1	BLOCK, CRIMPER SPACER	4
	1	1	4-1633962-4	CRIMPER, INSULATION F PREMIUM	3
-	1	1	455888-3	SPACER, CRIMPER	2
	1	1	2-456409-6	CRIMPER, WIRE .120 "F" PREMIUM	1
-	77-22		PART NO	DESCRIPTION	ITEM NO

<small>THE DRAWING IS UNPUBLISHED. IT IS SUBJECT TO CHANGE AND THE DRAWINGING INFORMATION SHOULD BE CONTACTED FOR THE LATEST REVISION.</small>		DWN Y. YIN 17AUG2015 CHK G. BAILEY 17AUG2015 APVD U. GUO 17AUG2015	TE Connectivity Harrisburg, PA 17105-3608
DIMENSIONS: mm 		TOLERANCES UNLESS OTHERWISE SPECIFIED: 0 PLC ± 1 PLC ± 2 PLC ± 3 PLC ± 4 PLC ± ANGLES FINISH ±	NAME Ocean End Feed Applicator SIZE CAGE CODE DRAWING NO A1 00779 C=2150611 RESTRICTED TO
MATERIAL:		WEIGHT:	SCALE 1:1 SHEET 3 OF 4 REV B Customer Accessible Production Drawing

LOC		DIST		REVISIONS			
A	66	P	LY#	DESCRIPTION	DATE	OWN	APVD
		-		SEE SHEET 1			

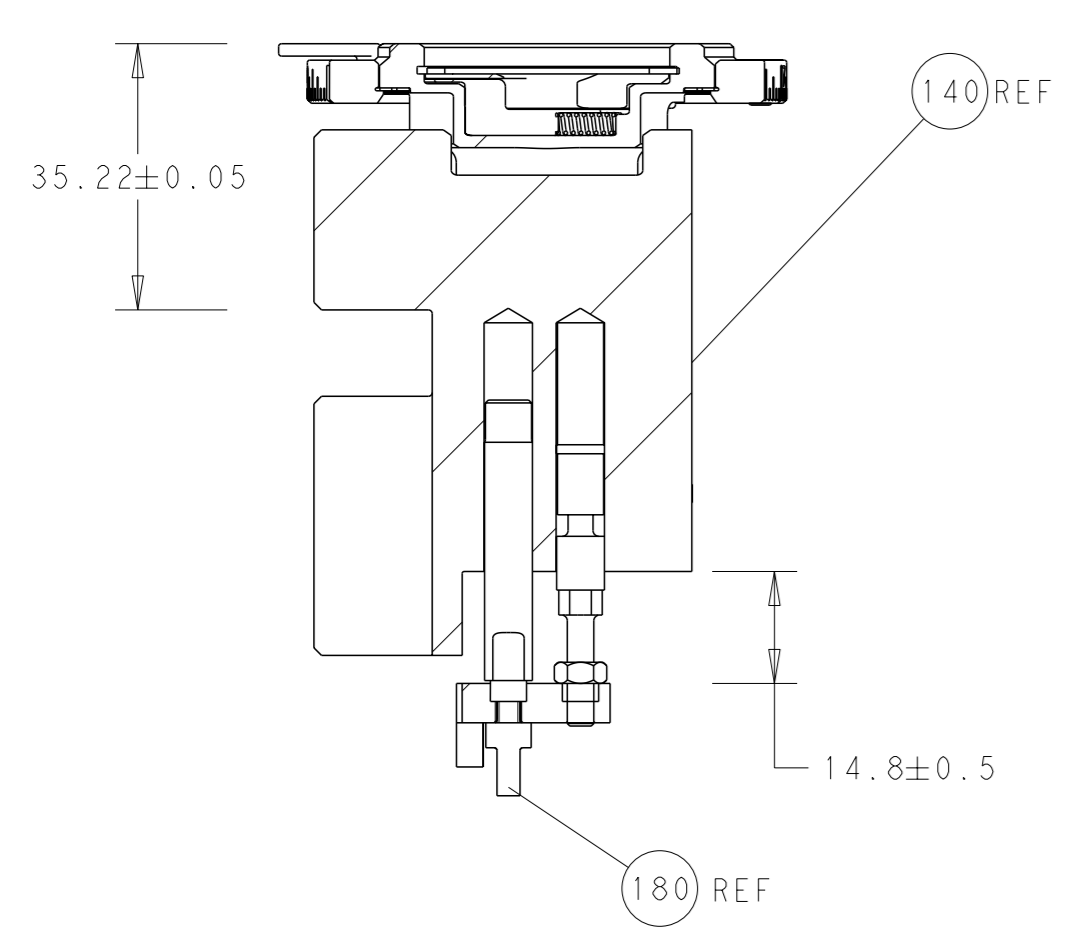

RAM AND HOLDDOWN SET-UP

FEED TYPE

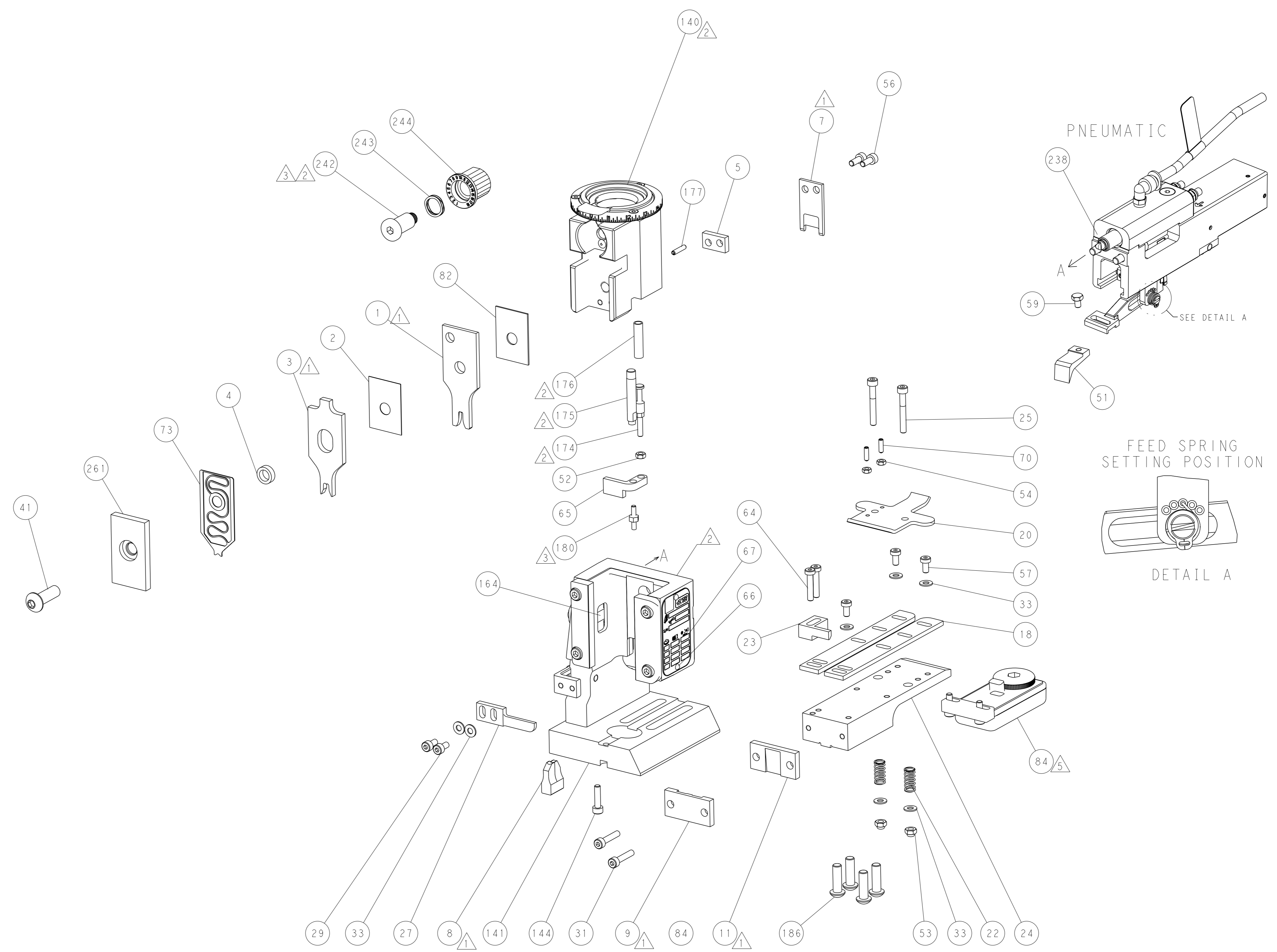

CAM POSITION

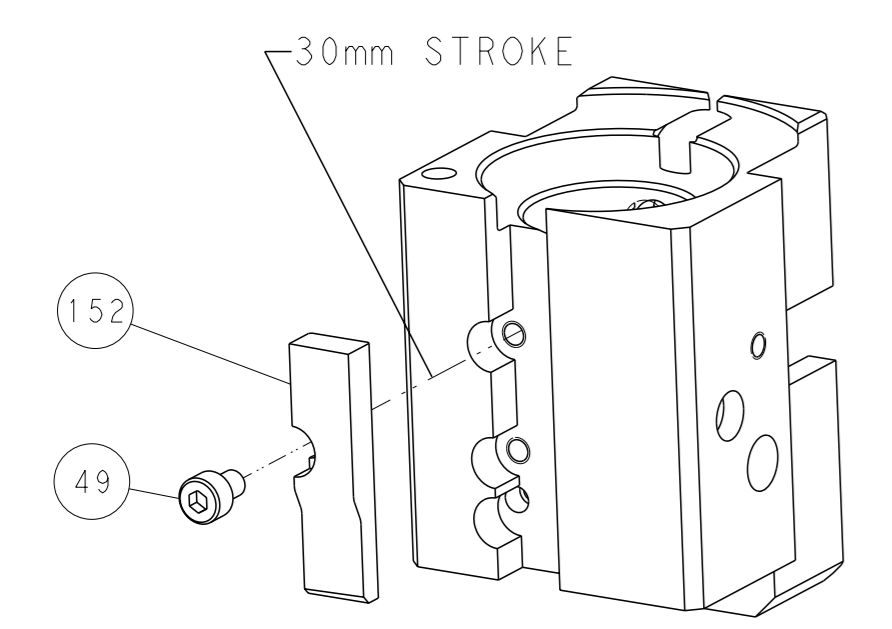

AIR FEED

PACIFIC VERSION
 Shown on sheets 3 of 4 & 4 of 4
 (Atlantic version shown on sheets 1 of 4 & 2 of 4)

<small>THIS DRAWING IS A CONTROLLED DOCUMENT FOR TYCO ELECTRONICS CORPORATION. IT IS SUBJECT TO CHANGE AND THE USER'S RESPONSIBILITY TO VERIFY THE IDENTIFICATION SHOULD BE CONTACTED FOR THE LATEST REVISION.</small>		DWN Y.YIN 17AUG2015 CHK G.BAILEY 17AUG2015 APVD H.GUO 17AUG2015	NAME Ocean End Feed Applicator
DIMENSIONS: mm 	TOLERANCES UNLESS OTHERWISE SPECIFIED: 0 PLC ± 1 PLC ± 2 PLC ± 3 PLC ± 4 PLC ± ANGLES FINISH ±	SIZE CAGE CODE DRAWING NO A 00779 C=2150611	RESTRICTED TO -
MATERIAL		WEIGHT -	SCALE 1:1 SHEET 4 OF 4 REV B
Customer Accessible Production Drawing		Customer Accessible Production Drawing	