

YOU NEED

- TMCM-1161
- Stepper motor (e.g. QSH5718, QSH6018)
- Serial interface: RS232, RS485, or USB
- If you choose RS485: RS485 interface converter suitable to your module
- Nominal supply voltage +24V DC (10... 30V DC)
- TMCL-IDE program and PC
- Cables for interface, motor, and power

STARTING UP

1. Choose your interface.
USB: connect USB interface to PC. Download and install the file *TMCM-1161.inf* (www.trinamic.com) after connecting the power supply.
RS485 or RS232: use the interface connector.
For communication via RS485 interpose an interface converter (e.g. USB-2-485). Connect the chosen interface to PC.
2. Connect the 24V DC power supply. Use pin 1 and pin 2 of the interface connector.
3. Connect motor to 4-pin connector of module.
4. Turn power ON. The green LED for power lights up and the motor is powered but in standstill now.
If this does not occur, turn power OFF and check your connections and power supply!
5. Start the TMCM-IDE program (see next page how to configure the connection and to use the IDE)
6. Type in the open window:

```

ROR 0, 500 //Rotate motor 0 with speed 500
WAIT TICKS, 0, 500
MST 0
ROR 0, 250 //Rotate motor 0 with speed 250
WAIT TICKS, 0, 500
MST 0

```

7. Click the *Assemble* icon. Thereafter click the *Download* icon to download the code to the module. Click the *Run* icon. The program will now be executed.
8. Click the *Stop* icon and start TMCL™ *Direct Mode* to issue the following commands:

ROR rotate right, motor 0, value 500 -> click *Execute* / The motor is rotating now.
MST motor stop, motor 0 -> click *Execute* / The motor stops now.

FIRST STEPS ARE MADE.

Please refer to the TMCM-1161 Hardware and Firmware Manuals, too.

PRECAUTIONS

- Do not mix up connections or short-circuit pins.
- Avoid bounding I/O wires with motor power wires.
- Do not exceed the maximum power supply of +30V DC!
- Do not connect or disconnect the motor while powered!
- **START WITH POWER SUPPLY OFF!**

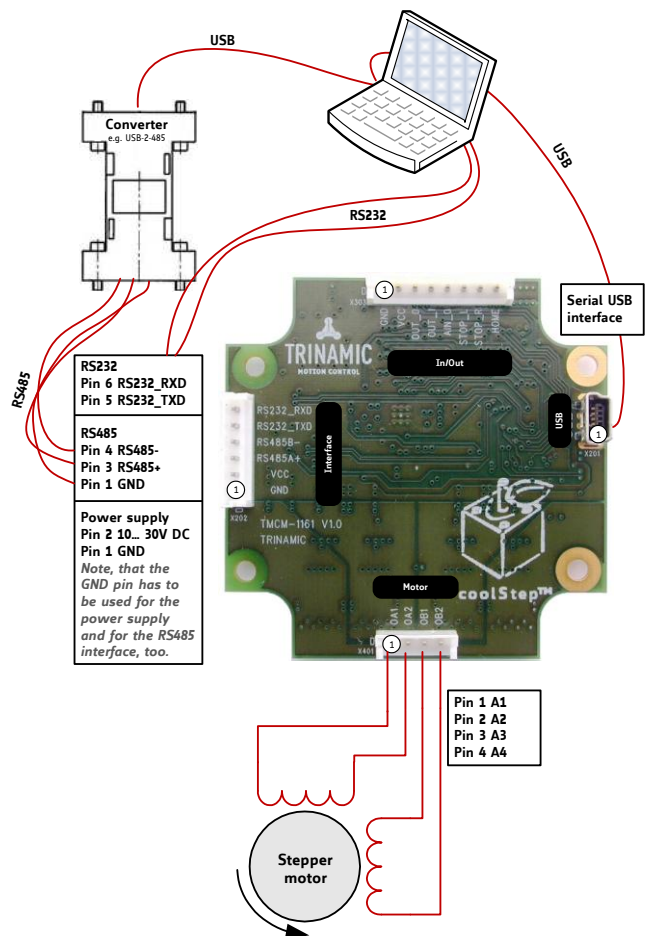

TMCL-IDE

The TMCL-IDE is available on www.trinamic.com.

1. Make sure the COM port you intend to use is not blocked by another program.
2. Open TMCL-IDE by clicking *TMCL.exe*.
3. Choose *Setup* and *Options* and thereafter the *Connection* tab.

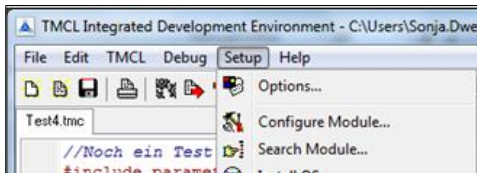

4. Choose *COM port* and *Type*. Click *OK*.

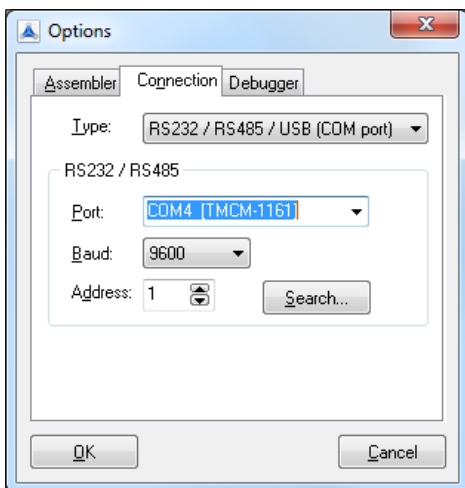

5. Write a program code into the white field and save it with *File/Save*. Note, that TMCL programs run standalone on the module, too.

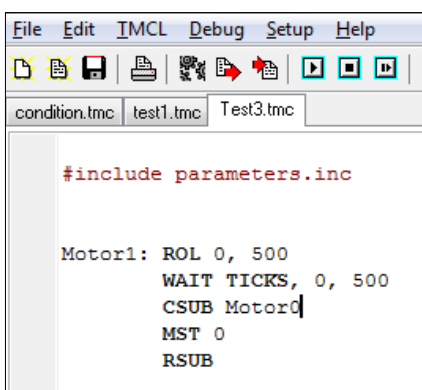

6. Click *Assemble* first, then *Download* and *Run* to start the program.

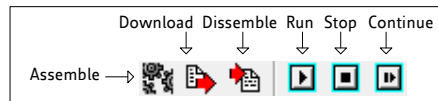

7. Stop all running programs by clicking *Stop* and start *Direct Mode* by clicking the appropriate icon.



8. The TMCM-1161 is automatically detected, if the communication is established.
9. Issue a command by choosing *Instruction*, *Type*, *Motor*, and *Value* and click *Execute* to send it to the module.

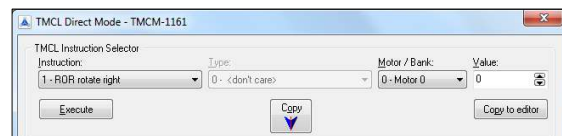

TROUBLESHOOTING

IF COMMUNICATION IS NOT ESTABLISHED

- Check if the green LED lights up. If not, check your power supply.
- Try to start *Direct Mode* and check, if the module is detected automatically.
- Check, if you are using the right COM port and it is not blocked by another program.
- Check, if the file *TMCM-1161.inf* is installed correctly.
- Check your connection settings. Default: 9600 baud, address 1.
- Check if your RS485 converter functions.

IF MOTOR DOES NOT RESPOND

- Usually the communication is not established (see above).
- Check the motor connection.
- If you are using a TMCL™ program try a movement command in *Direct Mode* to check if there is a problem with it.
- Restore factory settings by using instruction 137 for cancelling all settings modified by the user.