

PART NUMBER	REV	FIRST USED	POWER UNIT	FEED TYPE
1852821-1	A	122500-1	LEADMAKER & BENCH MODEL G	POST FEED
1852821-2	A	565435-5	BENCH MODEL K	POST FEED
7-1852821-7	A	-	SPARE PARTS	-

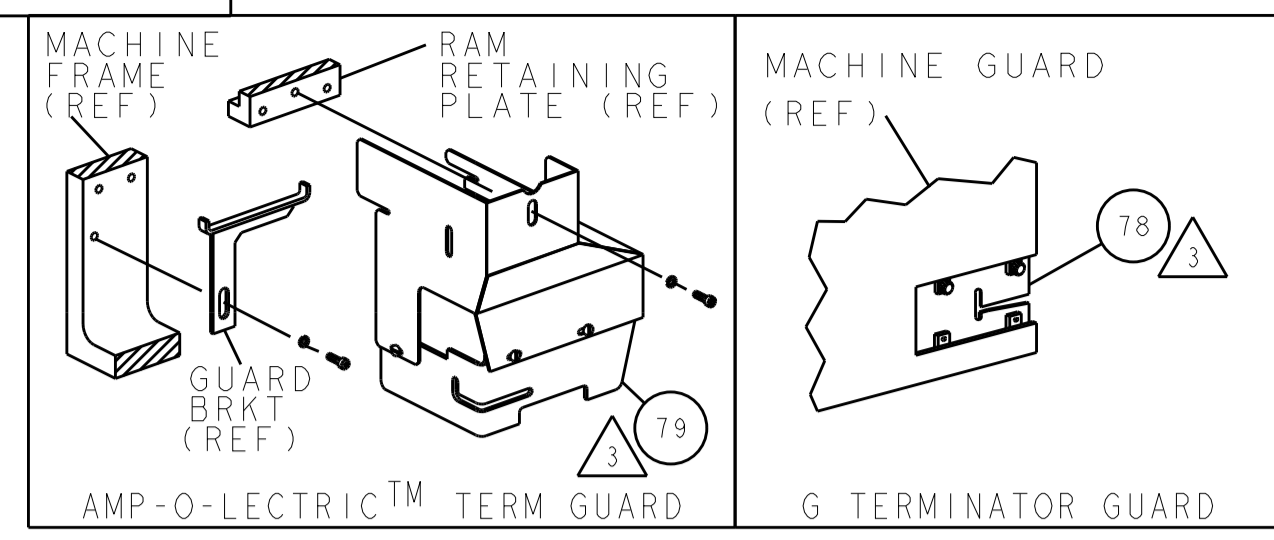

TERMINAL NAME: SPADE TERMINAL					
60251	41380	TE TERMINAL - TE CRIMP SPECS			
60355	-				
60456	-	PAD LTR	CRIMP HEIGHT	WIRE SIZE	
60600	-	A	.096±.002[2.44±0.05mm]	14AWG	
40760	-	B	.087±.002[2.21±0.05mm]	16AWG	
40761	-	C	.082±.002[2.08±0.05mm]	18AWG	
40762	-	D	-	-	
40784	-	CRIMP	SIZE	TYPE	RANGE
40802	-	-	-	-	-
40803	-	WIRE	.120 [3.05mm]	F	18-14 AWG
41209	-	INSUL	.210 [5.33mm]	F	∅.130-.180
WIRE STRIP LENGTH	TERM APPL SPEC	FEED	APPL INSTRUCTIONS	SET UP GAGE	
.173-.203	114-2084	.715	408-8039	458638-1	

LOC	DIST	REVISIONS			
A	66	REV	DESCRIPTION	DATE	OWN
		A	RELEASED	04MAR2009	LG
		A1	ECR-13-017162	04NOV2013	BH
		A2	ECR-13-017320	12NOV2013	BH

- △ RECOMMENDED SPARE PARTS
- △ GREASE LIGHTLY
- △ GUARD MUST BE IN PLACE WHEN OPERATING APPLICATOR IN A BENCH MACHINE

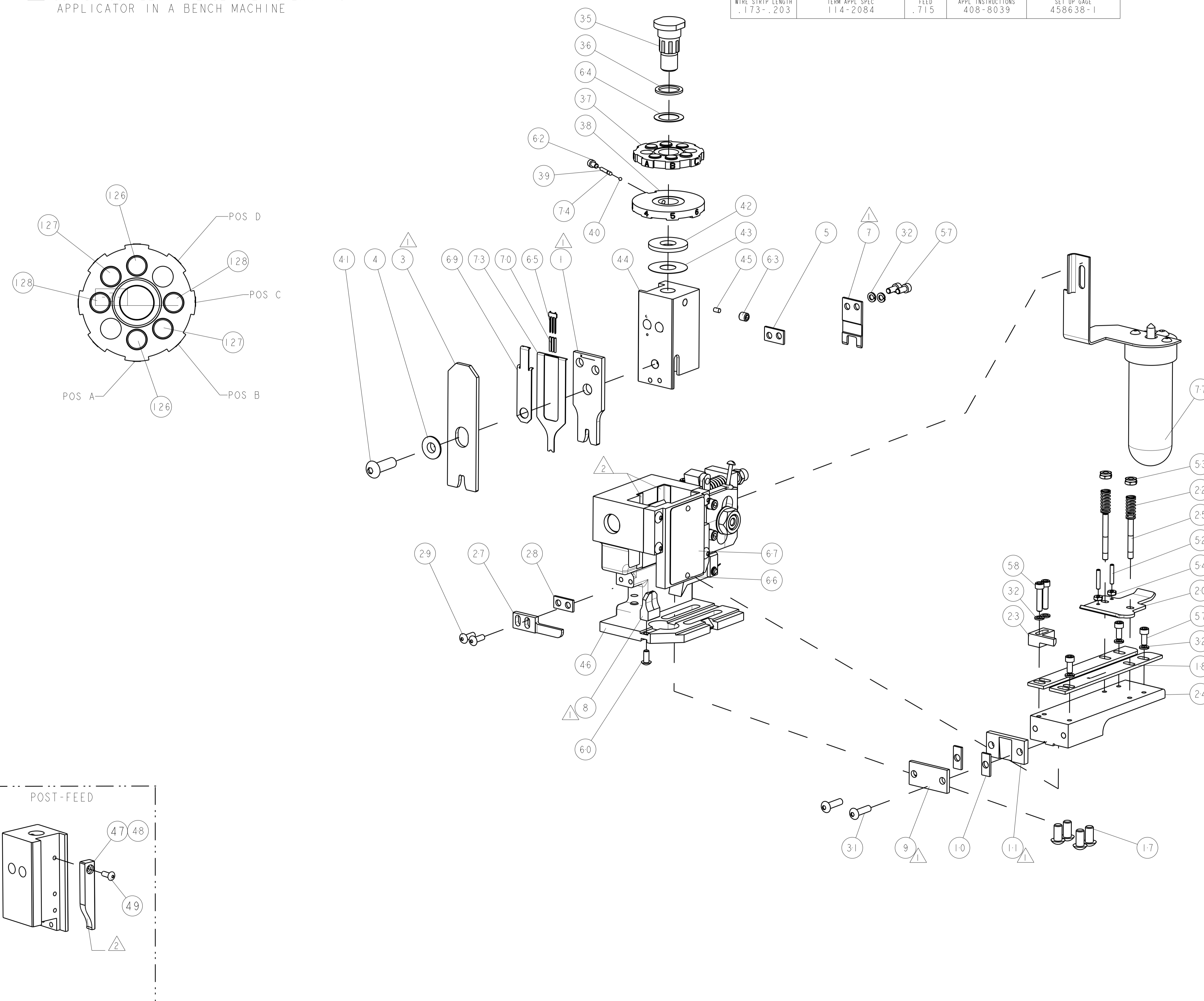

REV	QTY	UNIT	DESCRIPTION	ITEM NO	
-	2	2	7-354778-4	PIN, WIRE DISC, .2865	128
-	2	2	6-354778-3	PIN, WIRE DISC, .2810	127
-	2	2	4-354778-4	PIN, WIRE DISC, .2715	126
△	REF	-	455745-1	GUARD WINDOW	79
△	-	REF	679532-1	INSERT, GUARD	78
-	1	-	465184-9	LUBRICATOR ASSY	77
-	1	1	690603-1	SPRING ASSIST AMP-O-MATOR APPLICATOR	74
-	1	1	1490525-3	DEPRESSOR, WIRE	73
-	1	1	217238-1	GENERAL INSTRUCTION PKG	72
-	1	1	4088039	EF APPL INST 408-8039	71
-	3	3	2-23147-2	SPRING, COMPRESSION	70
-	1	1	1490524-1	DEPRESSOR, SPACER	69
-	1	1	461264-1	PLATE, IDENTIFICATION	67
-	2	2	21017-2	SCREW, DRIVE	66
-	1	1	1424350-1	HOLDER, PIN, WIRED	65
-	1	1	986950-1	WASHER, FLAT PRECISION	64
-	1	1	21009-2	SCR, SET, SELF LOCKING 1/4-20 X .250	63
-	1	1	23030-1	SCR, SKT HD CAP 6-32 X .25	62
-	1	1	22733-8	SCR, BHSC, SELF-LOCKING, 8-32 X .375	60
-	2	2	2-21000-9	SCR, SKT HD CAP 8-32 X .750	58
-	3	3	2-21000-6	SCR, SKT HD CAP 8-32 X .375	57
-	2	2	2-21000-6	SCR, SKT HD CAP 8-32 X .375	56
-	2	2	21018-4	NUT, HEX, REG 4-40	54
-	2	2	21022-2	NUT, LOCK, HEX, TORQUE, 8-32	53
-	2	2	2-21006-6	SCR, SET, CUP POINT 4-40 X .625	52
-	1	1	1-21002-7	SCR, BTN SKT CAP 6-32 X .375	49
-	1	-	690501-3	CAM, POST FEED, 1 1/8	48
-	-	1	690501-4	CAM, POST-FEED 1 5/8	47
-	1	1	458980-1	SUB ASSY, APPLICATOR FRAME	46
-	1	1	690191-1	PLUG, NYLON	45
-	1	1	455674-1	RAM	44
-	1	1	690125-1	SHIM SUB-ASSY	43
-	1	1	690124-1	WASHER, RAM (.115)	42
-	1	1	7-21002-9	SCR, BTN SKT HD CAP 5/16-24 X 1.00	41
-	1	1	23241-6	BALL, STEEL	40
-	1	1	690170-1	SPRING, COMPRESSION	39
-	1	1	690142-1	DISC, INSULATION	38
-	1	1	354777-1	WIRE DISC, ASSEMBLY	37
-	1	1	22480-5	SPRING, COMPRESSION	36
-	1	1	690212-1	POST, RAM	35
-	7	7	21024-4	WASHER, SPRG LOCK, REG NO 8	32
-	2	2	2-21002-9	SCR, BTN SKT HD CAP 10-32 X .750	31
-	2	2	2-21002-2	SCR, BTN SKT HD CAP 8-32 X .500	29
-	1	1	3-690451-2	SPACER, STRIPPER	28
-	1	1	240639-1	STRIPPER (MACHINING)	27
-	2	2	22354-8	STUD, THREADED	25
-	1	1	455678-1	PLATE, STRIP GUIDE	24
-	1	1	240825-3	PLATE, STRIP HOLD DOWN	23
-	2	2	4-22281-1	SPRING, DRAG	22
-	1	1	454177-1	DRAG	20
-	2	2	454204-3	GUIDE, LOWER STRIP	18
-	4	4	3-21002-3	SCR, BTN SKT HD CAP 1/4-20 X .500	17
△	1	1	240644-1	PLATE, REAR SHEAR	11
△	2	2	240645-7	SPACER, SHEAR PLATE	10
△	1	1	240642-1	PLATE, FRONT SHEAR	9
△	1	1	3-240693-8	ANVIL, COMBINATION	8
△	1	1	1-240651-3	BLADE, SLUG	7
-	-	-	-	-	6
-	1	1	3-240641-3	SPACER	5
-	1	1	238009-1	BLOCK, FL CRIMPER SPACER	4
△	1	1	1-456134-1	CRIMPER, INSULATION F PREMIUM	3
△	1	1	456409-3	CRIMPER, WIRE .120 "F" PREMIUM	1

DIMENSIONS:		TOLERANCES UNLESS OTHERWISE SPECIFIED:		DRAWN	
INCHES	0 PLC ±.01	1 PLC ±.01	2 PLC ±.01	3 PLC ±.001	4 PLC ±.0001
	ANGLES ±.0001	FINISH			
MATERIAL		WEIGHT		SCALE	3:5
Customer Drawing		Customer Drawing		SHEET	1 OF 1

CUSTOMER VIEWABLE ASSEMBLY