

**Pb** THIS PRODUCT MANUFACTURED WITH LEAD-FREE PROCESSING

**DESIGNED & DIMENSIONED IN MILLIMETERS[INCHES]**

DO NOT SCALE FROM THIS PRINT

**SMA-P-C-XX-ST-C47**

GENDER -P: PLUG  
 TYPE -C: CABLE  
 ORIENTATION -ST: STRAIGHT  
 TERMINATION -C47: CCA-047-X CABLE  
 PLATING SPECIFICATION -HF: 30µ" GOLD CENTER CONTACT, 3µ" GOLD OUTER CONTACT (SEE TABLE 1)

TABLE 1		
ITEM	COMPONENT	-HF
1	SUB ASSEMBLY	SUB-SMA-P-C-XX-ST-C47

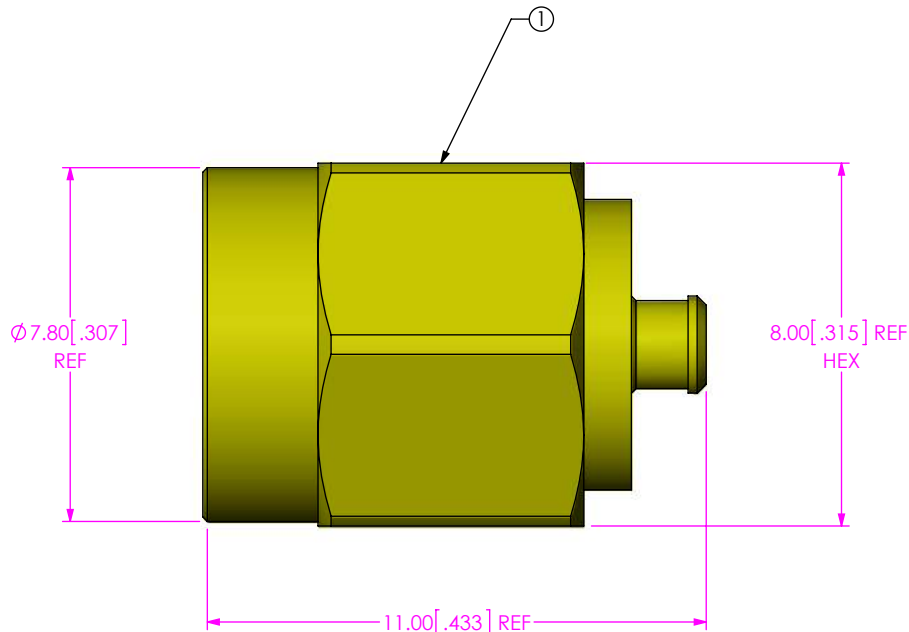

NOTES:

1.  $\text{⌀}$  REPRESENTS A CRITICAL DIMENSION.
2. PRODUCT TO BE PACKAGED PER PACKING STANDARD CO-RF-WI-3040-M.

UNLESS OTHERWISE SPECIFIED, DIMENSIONS ARE IN MILLIMETERS.  
 TOLERANCES ARE:  
 DECIMALS ANGLES  
 X.X: ±0.3 [.01] 5°  
 X.XX: ±0.13 [.005]  
 X.XXX: ±0.051 [.0020]

**PROPRIETARY NOTE**  
 THIS DOCUMENT CONTAINS CONFIDENTIAL AND PROPRIETARY INFORMATION AND ALL DESIGN, MANUFACTURING, REPRODUCTION, USE, PATENT RIGHTS AND SALES RIGHTS ARE EXPRESSLY RESERVED BY SAMTEC, INC. THIS DOCUMENT SHALL NOT BE DISCLOSED, IN WHOLE OR PART, TO ANY UNAUTHORIZED PERSON OR ENTITY NOR REPRODUCED, TRANSFERRED OR INCORPORATED IN ANY OTHER PROJECT IN ANY MANNER WITHOUT THE EXPRESS WRITTEN CONSENT OF SAMTEC, INC.



520 PARK EAST BLVD, NEW ALBANY, IN 47150  
 PHONE: 812-944-6733 FAX: 812-948-5047  
 e-Mail info@SAMTEC.com code 55322

MATERIAL: DO NOT SCALE DRAWING SHEET SCALE: 6:1  
 PIN: BeCu  
 CABLE BODY, NUT: BRASS  
 INSULATOR: PTFE  
 GASKET: SILICONE  
 C-RING: STAINLESS STEEL

DESCRIPTION: SMA ST PLUG FOR C47 CABLE  
 DWG. NO. SMA-P-C-XX-ST-C47  
 BY: EMMA CHEN 8/13/2013 SHEET 1 OF 2

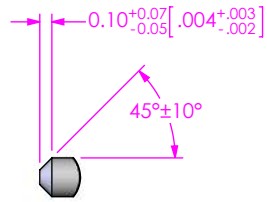

DETAIL 'B'  
SCALE 16:1

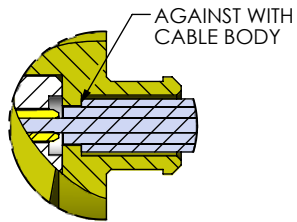

DETAIL 'C'  
SCALE 6:1

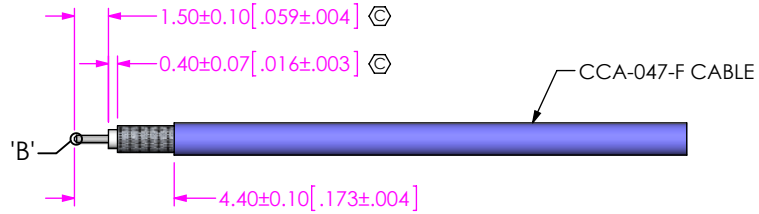

IN-PROCESS 1  
STRIP

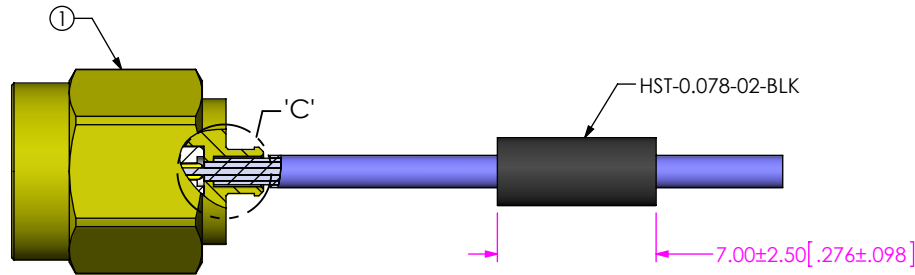

IN-PROCESS 2  
ADD SUB ASSEMBLY & HEAT SHRINK TUBE

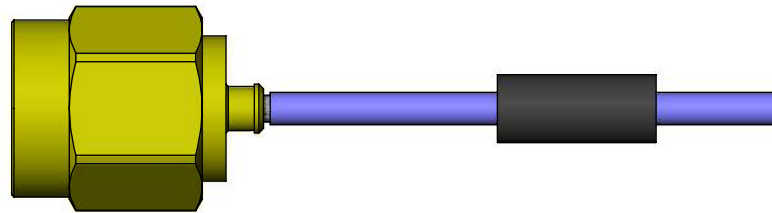

IN-PROCESS 3  
SOLDER CABLE TO CABLE BODY

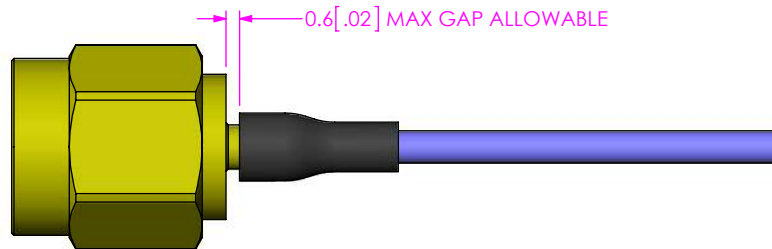

IN-PROCESS 4  
APPLY HEAT TO SHRINK TUBING

F:\DWG\MISC\MKTG\SMA-P-C-XX-ST-C47-MKT.SLDDRW

<p>DO NOT SCALE DRAWING</p> <p>SHEET SCALE: 3:1</p>	<p><b>PROPRIETARY NOTE</b></p> <p>THIS DOCUMENT CONTAINS CONFIDENTIAL AND PROPRIETARY INFORMATION AND ALL DESIGN, MANUFACTURING, REPRODUCTION, USE, PATENT RIGHTS AND SALES RIGHTS ARE EXPRESSLY RESERVED BY SAMTEC, INC. THIS DOCUMENT SHALL NOT BE DISCLOSED, IN WHOLE OR PART, TO ANY UNAUTHORIZED PERSON OR ENTITY NOR REPRODUCED, TRANSFERRED OR INCORPORATED IN ANY OTHER PROJECT IN ANY MANNER WITHOUT THE EXPRESS WRITTEN CONSENT OF SAMTEC, INC.</p>	<p><b>samtec</b></p> <p>520 PARK EAST BLVD, NEW ALBANY, IN 47150 PHONE: 812-944-6733 FAX: 812-948-5047 e-Mail info@SAMTEC.com code 55322</p>
	<p>DESCRIPTION:</p> <p>SMA ST PLUG FOR C47 CABLE</p>	
	<p>DWG. NO.</p> <p>SMA-P-C-XX-ST-C47</p>	
<p>BY: EMMA CHEN 8/13/2013</p>		<p>SHEET 2 OF 2</p>