

PCM-9375 A3

AMD Geode™ LX800 3.5" SBC

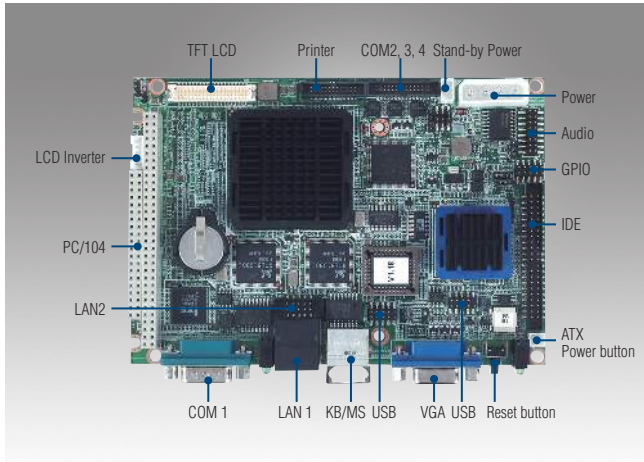

Features

- AMD Geode™ low-power LX800 500 MHz processor
- DDR 333 MHz up to 1GB
- 24 bit TFT LCD/ LVDS LCD Display
- Dual 10/100 Mbps Fast Ethernet, 4COM ports, 4 USB ports
- Expansion: PC/104
- Supports SUSIAccess and Embedded Software APIs

Software APIs:



Utilities:



Specifications

Processor System	CPU	AMD Geode LX800 processor, up to 500 MHz
	Frequency	500 MHz
	L2 Cache	128 KB
	System Chipset	AMD Geode CS5536
	BIOS	Award 8 Mb Flash ROM BIOS
Memory	Technology	DDR 333 MHz
	Max. Capacity	1 GB
Display	Socket	1 x 200-pin SODIMM
	Chipset	AMD Geode LX800
	VRAM	Optimized shared memory architecture up to 64 MB system memory
	Graphics Engine	AMD Geode LX800 2D engine
	LVDS	1 x Single channel 24-bit LVDS (JEIDA format), up to 1600 x 1200 x 32 bpp at 60 Hz
	VGA	VGA: up to 1920 x 1440 @ 32 bpp (85 Hz)
	TTL LCD	1 x 24-bit TTL (PCM-9375F), up to 1600 x 1200 x 32 bpp at 60 Hz
Ethernet	Dual Display	VGA+TTL, VGA+LVDS
	Speed	10/100 Mbps (Supports Wake on LAN)
Audio	Controller	Ethernet1 Realtek RTL8139 10/100 Mbps Ethernet2 Realtek RTL8139 10/100 Mbps
	Connector	RJ-45 on Ethernet1, box header on Ethernet2
WatchDog Timer	Chipset	Realtek ACL655, Line-in, Line-out, Mic-in
Storage	Output System reset, Programmable counter from 1 ~ 255 minutes/seconds	
	CompactFlash	CompactFlash type I/II (Primary Master IDE Channel)
	IDE	1
Rear I/O	Floppy	1 (Shared with LPT)
	Serial	1 (COM1 supports RS-232) (ESD protection for RS-232: Air gap ±15kV, Contact ±8kV)
	Ethernet	1 (10/100 Mbps)
	PS/2 KB/Mouse	1
	VGA	1
	PWR&HDD LED	1
	Reset Button	1
Internal I/O	USB	4 x USB 2.0
	Serial	3 x COM (ESD protection for RS-232: Air gap ±15kV, Contact ±8kV) COM3/COM4 supports RS-232 COM2 supports RS-232/422/485 (Supports RS-485 auto flow control)
	Ethernet	1 (10/100 Mbps)
	IDE	1 UDMA 33/66
	Parallel (LPT)	1 (Shared with FDD)
	FDD	1 (Shared with LPT)
	GPIO	8-bit GPIO
	I ² C	optional
Expansion	PC/104 Slot	PC/104 Expansion(8/16-Bit ISA)
	Power Type	AT/ATX
	Power Supply Voltage	5V + 5% (+12V option for LCD, PC/104)
	Power Consumption (Typical)	0.6 A @ 5 V, 0.03 A @ 12 V (3.36 W)
	Power Consumption (Max, test in HCT)	1.2 A @ 5 V, 0.23 A @ 12 V (8.76 W)
	Power Management	APM 1.2, ACPI
Environment	Battery	Lithium 3 V/196 mAh
	Operational	Operating: Standard: 0 ~ 60° C (32 ~ 140° F), Extend: -40 ~ 85° C (-40 ~ 185° F) Storage: -40 ~ 85° C (-40 ~ 185° F)
Physical Characteristics	Non-Operational	-40° C ~ 85° C and 60° C @ 95% RH non-condensing
	Dimensions (L x W)	146 x 102 mm (5.7" x 4")
	Weight	0.64 kg (1.41 lb), weight of total package
	Total Height	25.2mm

Block Diagram

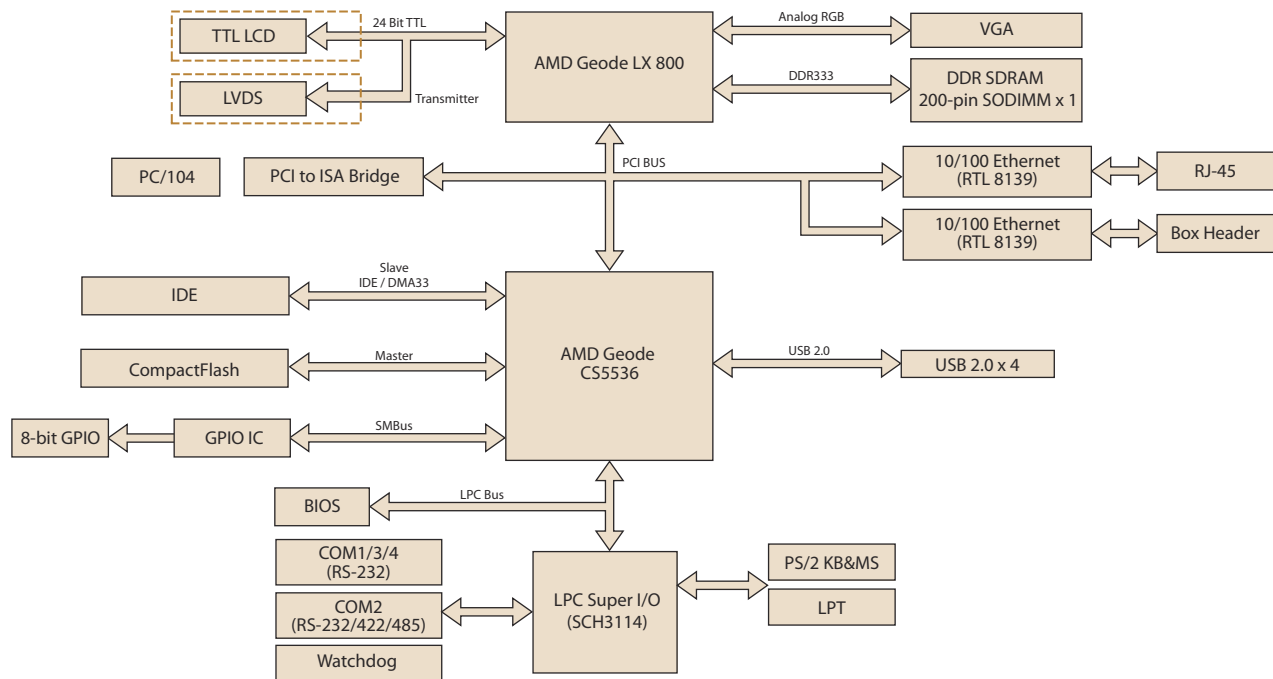

Ordering Information

Part No.	CPU	Memory	VGA	LVDS	TTL	10/100 Ethernet	Audio	IDE	USB2.0	RS-232	RS-232/422/485	CF	Expansion	Thermal Solution	Operating Temp.
PCM-9375F-J0A3N	AMD LX800	SODIMM	1	-	1	2	No	1 IDE	4	3	1	1	PC/104	Passive	0 ~ 60° C
PCM-9375E-J0A3N	AMD LX800	SODIMM	1	24-bit	-	2	No	1 IDE	4	3	1	1	PC/104	Passive	0 ~ 60° C
PCM-9375FZ-J0A3N	AMD LX800	SODIMM	1	-	1	2	No	1 IDE	4	3	1	1	PC/104	Passive	-20 ~ 80° C
PCM-9375EZ-J0A3N	AMD LX800	SODIMM	1	24-bit	-	2	No	1 IDE	4	3	1	1	PC/104	Passive	-20 ~ 80° C
PCM-9375FZ2-J0A3N	AMD LX800	SODIMM	1	-	1	2	No	1 IDE	4	3	1	1	PC/104	Passive	-40 ~ 85° C
PCM-9375EZ2-J0A3N	AMD LX800	SODIMM	1	24-bit	-	2	No	1 IDE	4	3	1	1	PC/104	Passive	-40 ~ 85° C

Note: Passive = fanless; Active = with fan

Packing List

Part No.	Description	Quantity
	PCM-9375 SBC	
	Startup Manual	
	Utility CD	
1701440351	IDE cable (44p/44p) 35cm	1
1700060202	KB/MS cable 20cm	1
1701100202	LAN cable 20cm	1
1700001971	COM 2/3/4 RS-232 cable 21 cm	1
1700001977	Parallel Port cable 25cm	1
1700160160	Audio cable 16 cm	1
1703100121	USB cable (2 ports) w/ bracket 12cm	1
1960004868	LX800 heatsink for PCM-9375 39.5 x 39.6 x 9.8 mm	
1960004869	CS5536 heatsink for PCM-9375 22.6 x 22.6 x 14.5 mm	

Rear I/O View



Optional Accessories

Part No.	Description
1703040157	COM2 cable for RS-422/485
1703200201	ATX power control cable
9696937580E	PCM-9375-FDD module (must connect 1701340700 and 1700002212)
1701340700	Flat cable 34-pin for 9696937580E, 70cm (cable from 9696937580E's FDD port to FDD device)
1700002212	LPT Cable for 9696937580E, 1.27mm pitch, 10cm (cable from PCM-9375's LPT to 9696937580E's LPT)

Embedded OS/API

Embedded OS/API	Part No.	Description
WinCE	TBD	Image PCM-9375 CE 5.0 Pro Plus Eng
	TBD	CE 6.0 Pro GX3 4Com V1.0 ENG
	TBD	CE 6.0 Pro PCM-9375_4COM V1.1 JPN
	TBD	CE 6.0 Pro GX3 4COM V1.2 ENG
Win XPE	20706WE09S0001	WES2009 ENG V4.0
	TBD	WES2009 24MUI V4.0