

General Description

The MIC2551A is a single chip transceiver that complies with the physical layer specifications of the Universal Serial Bus (USB) 2.0. It supports both full speed (12Mbps) and low speed (1.5Mbps) operation and introduces superior edge rate control, producing crisper eye diagrams. This in turn, eases the task of passing USB compliance testing.

A unique, patented, dual supply voltage operation allows the MIC2551A to reference the system I/F I/O signals to a supply voltage down to 1.6V while independently powered by the USB V_{BUS} . This reduces system operating current and allows the system to operate at its core voltage without additional buffering logic.

MIC2551A-2.5 is differentiated from MIC2551A by a smaller space saving MLF[®] package (2.5mm × 2.5mm) and ±15kV ESD protection which eliminates the need for separate ESD protection devices on the D+, D- data lines.

Data sheets and support documentation can be found on Micrel's web site at www.micrel.com.

Features

- ±15kV ESD protection on V_{BUS} , D+ and D-
- Smaller 2.5mm × 2.5mm MLF[®] package
- USB 1.1 and 2.0 compliant transceiver (full speed - 12Mbps and low speed - 1.5Mbps) operation
- Separate I/O supply with operation down to 1.6V
- Integrated speed select termination supply
- Very-low power consumption to meet USB suspend current requirements
- No power supply sequencing requirements
- Software controlled enumeration

Applications

- PDAs
- Palmtops
- Cell phones
- PC peripherals

Ordering Information

Part Number	Junction Temp. Range	Package - Pb Free
MIC2551AYML25	-40°C to +85°C	2.5mm×2.5mm MLF [®]

Typical Application

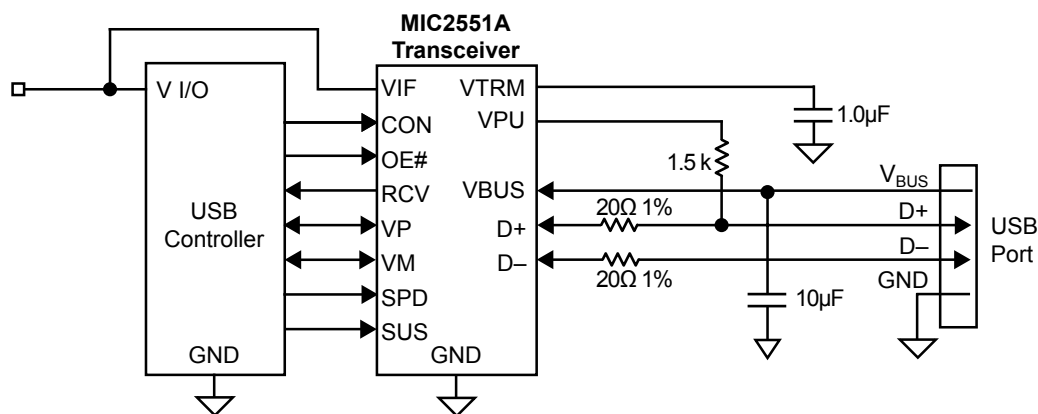

Typical Application Circuit

Pin Configuration

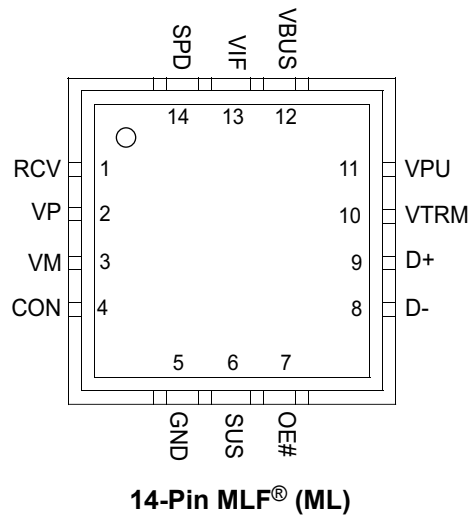

Pin Description

Pin Number	Pin Name	I/O	Pin Description
1	RCV	O	Receive Data: Output for USB differential data.
2	VP	I/O	If OE# = 1, VP = Receive output (+) If OE# = 0, VP = Driver input (+).
3	VM	I/O	If OE# = 1, VM = Receive output (-) If OE# = 0, VM = Driver input (-).
4	CON	I	CONNECT (Input): Controls state of VPU. Refer to VPU pin description for detail.
5	GND		Ground Reference.
6	SUS	I	Suspend: Active-High. Turns off internal circuits to reduce supply current.
7	OE#	I	Output Enable: Active-Low. Enables the transceiver to transmit data onto the bus. When inactive, the trasceiver is in the receive mode.
8	D-	I/O	Differential data lines conforming to the USB standard.
9	D+		
10	VTRM	O	3.3V Reference Supply Output: Requires a minimum 0.1µF decoupling capacitor for stability. A 1µF capacitor is recommended.
11	VPU	O	Pull-up Supply Voltage Output: Used to connect 1.5kΩ pull-up speed detect resistor. If CON = 1, VPU is high impedance. If CON = 0, VPU = 3.3V.
12	VBUS	I	USB Bus Supply Voltage: Used to power USB transceiver and internal circuitry.
13	VIF	I	System Interface Supply Voltage: Used to provide reference supply voltage for system I/O interface signaling.
14	SPD	I	Edge Rate Control: A logic HIGH operates at edge rates for "full speed" operation. A logic LOW operates edge rates for "low-speed" operation.

SUS	OE#	D+, D-	RCV	VP/VM	Function
0	0	Driving	Active	Active	Normal transmit mode.
0	1	Receiving	Active	Active	Normal receive mode.
1	0	Hi-Z	0	Not Active	Low power state.
1	1	Hi-Z	0	Active	Receiving during suspend (low power state) (Note 1)

Note 1. During suspend, VP and VM are active in order to detect out-of-band signaling conditions.

Table 1. Function Selection

OE# = 0:					
Input		Output			Result
VP	VM	D+	D-	RCV	
0	0	0	0	X	SE0
0	1	0	1	0	Logic 0
1	0	1	0	1	Logic 1
1	1	1	1	X	Undefined
OE# = 1:					
Input		Output			Result
D+	D-	VP	VM	RCV	
0	0	0	0	X	SE0
0	1	0	1	0	Logic 0
1	0	1	0	1	Logic 1
1	1	1	1	X	Undefined

X - Undefined

Table 2. Truth Table During Normal Mode

Absolute Maximum Ratings (Note 1)

Supply Voltage (V_{BUS})..... 6.5V
 All Other Inputs.....-0.5V to 5.5V
 Ambient Storage Temperature..... -65°C to +150°C
 Output Current (D+, D-)..... ± 50 mA
 Output Current (all others)..... ± 15 mA
 Input Current..... ± 50 mA

ESD, Note 3

V_{BUS} , D+, D-..... ± 15 KV
 All other pins..... ± 2 KV

Operating Ratings (Note 2)

Supply Voltage (V_{BUS}).....4.0V to 5.25V
 Ambient Operating Temperature -40°C to +85°C
 Package Thermal Resistance
 MLF® (θ_{JA}).....59(°C/W)

DC Electrical Characteristics (System and USB Interface) (Note 6)

$V_{IF} = 3.6V$, $V_{BUS} = 5V$ unless otherwise noted; $T_A = 25^\circ C$. **Bold** indicates specifications over temperature, -40°C to 85°C.

Symbol	Parameter	Conditions	Min	Typ	Max	Units
V_{BUS}	USB Supply Voltage		4.0		5.25	V
V_{IF}	System I/F Supply Voltage		1.6		3.6	V
V_{IL}	LOW-Level Input Voltage, Note 4		$V_{IF}-0.3$		$0.15V_{IF}$	V
V_{IH}	HIGH-Level Input Voltage, Note 4		$0.85V_{IF}$		$V_{IF}+0.3$	V
V_{OH}	HIGH-Level Output Voltage, Note 4	$I_{OH} = 20\mu A$	$0.9V_{IF}$			V
V_{OL}	LOW-Level Output Voltage, Note 4	$I_{OL} = 20\mu A$			0.1	V
I_{IL}	Input Leakage Current, Note 4		-5		5	μA

Symbol	Parameter	Conditions					Min	Typ	Max	Units		
		SPD	SUS	OE#	Voltage	Load						
I_{IF}	VIF Supply Current	1	0	1	$V_{BUS} = 5.25V$ $V_{IF} = 3.6V$		1	5	μA			
		1	0	0								
		0	0	1								
		0	0	0								
		0	1	0								
		1	0	0		f = 6MHz CLOAD = 50pF, Note 6				325	650	μA
		0	0	0		f = 750MHz CLOAD = 600pF, Note 6				40	75	μA
I_{VBUS}	VBUS Supply Current	1	0	1	$V_{BUS} = 5.25V$ $V_{IF} = 3.6V$		800	1100	μA			
		1	0	0			3000	5000	μA			
		0	0	1			230	350	μA			
		0	0	0			400	700	μA			
		0	1	0			130	200	μA			
		1	0	0		f = 6MHz CLOAD = 50pF, Note 6	7.3	10	mA			
		0	0	0		f = 750MHz CLOAD = 600pF, Note 6	3.6	5	mA			

Symbol	Parameter	Conditions	Min	Typ	Max	Units
$I_{VPULEAK}$	VPU Leakage Current	CON = 1, $V_{PU} = 0V$	-5		5	μA
$I_{VIFLEAK}$	VIF Leakage Current	$V_{IF} = 3.6V$, $V_{BUS} = 0V$	-5		5	μA
V_{PU}	Pull-Up Output Voltage	$I_{TERM} = 200\mu A$, $V_{BUS} = 4.0$ to 5.25V	3.0	3.3	3.6	V
R_{SW}	Internal Pull-Up Termination	$I_{TERM} = 10mA$, $V_{BUS} = 4.0$ to 5.25V		10		Ω

Symbol	Parameter	Conditions	Min	Typ	Max	Units
ESD Protection						
IEC-1000-4-2 (D+, D-, V _{BUS} only)	Air Discharge	10 pulses		±15		kV
	Contact Discharge	10 pulses		±15		kV

DC Electrical Characteristics (Transceiver) (Note 6)

Leakage Current						
I _{LO}	Hi-Z State Data Line Leakage (Suspend Mode)	0V < V _{IN} < 3.3V, SUS = 1	-10		10	µA
Input Levels						
V _{DI}	Differential Input Sensitivity	(D+) - (D-)	0.2			V
V _{CM}	Differential Common Mode Range	Includes V _{DI} range	0.8		2.5	V
V _{SE}	Single-Ended Receiver Threshold		0.8		2.0	V
	Receiver Hysteresis			200		mV
Output Levels						
V _{OL}	Static Output Low	R _L = 1.5kΩ to 3.6V			0.3	V
V _{OH}	Static Output High	R _L = 1.5kΩ to GND	2.8		3.6	V
Capacitance						
C _{IN}	Transceiver Capacitance	Pin to GND		10		pF
Z _{RDV}	Driver Output Resistance	Steady-state drive	8	16	24	Ω

AC Electrical Characteristics (Notes 5)

Driver Characteristics (Low Speed)						
T _R	Transition Rise Time	C _L = 50pF, Figure 2 C _L = 600pF	75		300	ns
T _F	Transition Fall Time	C _L = 50pF, Figure 2 C _L = 600pF	75		300	ns
T _R , T _F	Rise/Fall Time Matching	(T _R , T _F)	80		125	%
V _{CRS}	Output Signal Crossover Voltage		1.3		2.0	V
Driver Characteristics (Full Speed)						
T _R	Transition Rise Time	C _L = 50pF, Figure 2	4		20	ns
T _F	Transition Fall Time	C _L = 50pF, Figure 2	4		20	ns
T _R , T _F	Rise/Fall Time Matching	(T _R , T _F)	90		111.11	%
V _{CRS}	Output Signal Crossover Voltage		1.3		2.0	V

Transceiver Timing						
t _{PVZ}	OE# to RCVR Tri-State Delay	Figure 1			15	ns
t _{PZD}	Receiver Tri-State to Transmit Delay	Figure 1	15			ns
t _{PDZ}	OE# to DRVR Tri-State Delay	Figure 1			15	ns
t _{PZV}	Driver Tri-State to Receiver Delay	Figure 1	15			ns
t _{PLH} t _{PHL}	VP, VM to D+, D- Propagation Delay	Figure 4			15	ns
t _{PLH} t _{PHL}	D+, D- to RCV Propagation Delay	Figure 3			15	ns
t _{PLH} t _{PHL}	D+, D- to VP, VM Propagation Delay	Figure 3			8	ns

Note 1. Exceeding the absolute maximum rating may damage the device.

Note 2. The device is not guaranteed to function outside its operating rating.

Note 3. Devices are ESD sensitive. Handling precautions recommended. Human body model, 1.5k in series with 100pF.

Note 4. Specification applies to the following pins: SUS, SPD, CON, RCV, VP, VM, OE#.

Note 5. All AC parameters guaranteed by design but not production tested.

Note 6. Specification for packaged product only.

Timing Diagrams

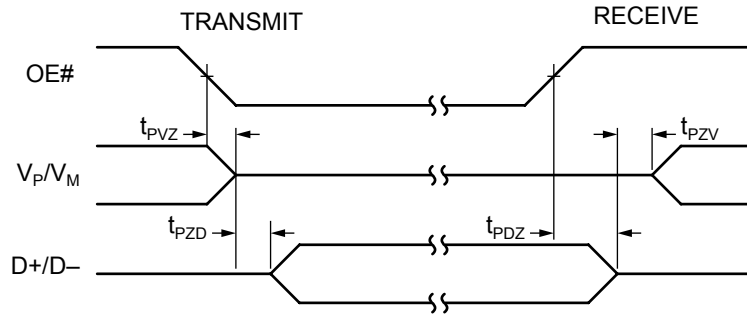

Figure 1. Enable and Disable Times

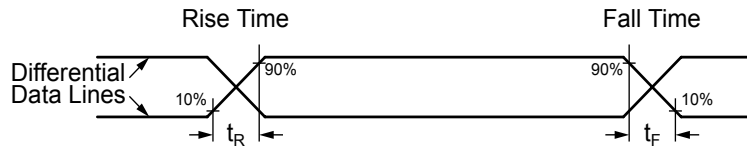

Figure 2. Rise and Fall Times

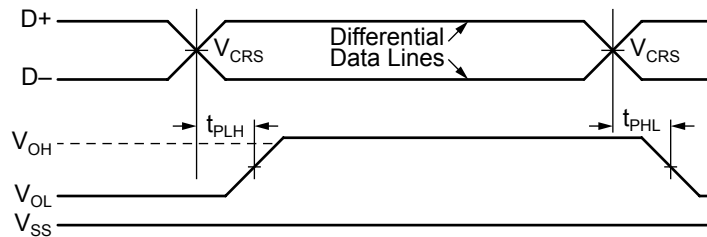

Figure 3. Receiver Propagation Delay

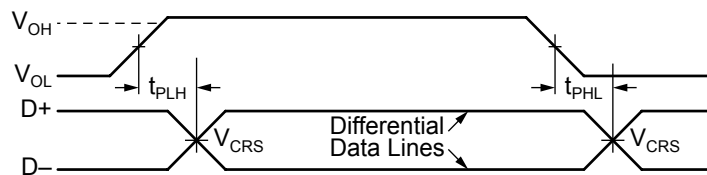

Figure 4. Driver Propagation Delay

Test Circuits

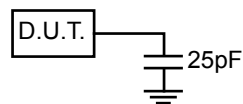

Figure 5. Load for V_P, V_M, RCV

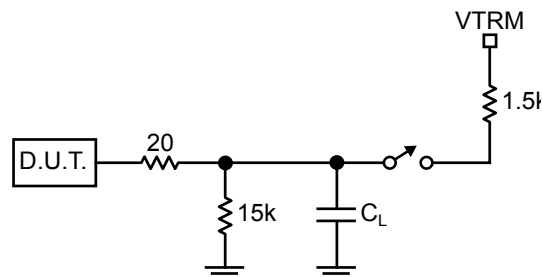
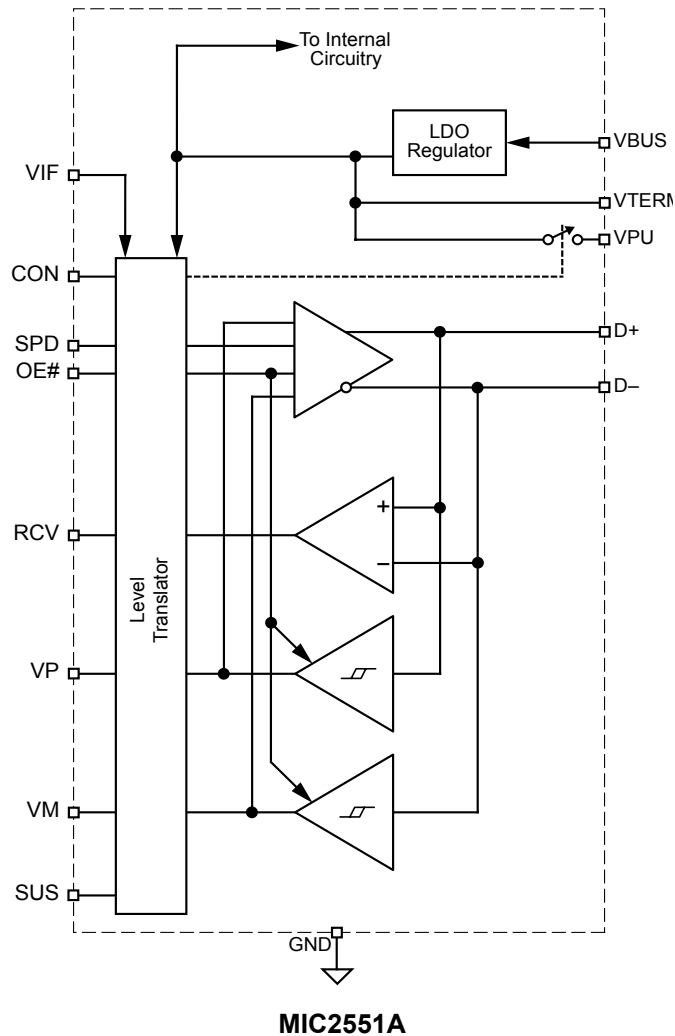

Figure 6. Load for D+, D-

Functional Diagram



Applications Information

The MIC2551A is designed to provide USB connectivity in mobile systems where available system supply voltages are not able to satisfy USB requirements. The MIC2551A can operate interface supply voltages as low as 1.6V and still meet the USB physical layer specifications. As shown in the circuit above, the MIC2551A takes advantage of the USB supply voltage, V_{BUS} , to operate the transceiver. The system voltage, V_{IF} , is used to set the reference voltage used by the digital I/O lines interfacing to the system controller. Internal circuitry provides translation between the USB and system voltage domains. V_{IF} will typically be the main supply voltage rail for the controller.

In addition, a 3.3V, 10% termination supply voltage, (V_{PU}), is provided to support speed selection. V_{PU} can be disabled or enabled under software control via the CON input. This allows for software-controlled connect or disconnect states. A 1.5k resistor is required to be connected between this pin and the D+ or D- lines to respectively specify high speed or low speed operation.

Power Supply Configuration

The MIC2551A can be set up for different power supply configurations which modify the behavior of the device. Both V_{BUS} and V_{IF} have special thresholds that detect when they are either removed or grounded. Table 1 depicts the behavior under the different power supply configuration scenarios that are explained below.

Normal Mode

V_{BUS} is connected to the 5.0V USB bus voltage and V_{IF} is connected to a supply voltage in the range of 1.6V to 3.6V. In this case V_{TRM} supplies a 3.3V voltage for powering the speed select resistor via V_{PU} depending on the state of CON pin.

Disconnect Mode

V_{IF} is connected to a supply in a range of 1.6V to 3.6V and V_{BUS} is open or grounded. If V_{BUS} is opened while transmitting, the data lines (D+, D-) have sharing capability and may be driven with external devices up to approximately 3.6V if and only if SUSPEND is enabled ($SUS = 1$). With V_{BUS} ground, D+, D- sharing mode is not permitted.

Disable Mode

V_{BUS} is connected to the 5.0V USB bus voltage and V_{IF} is open. All logic controlled inputs become high impedances, thus minimal current will be supplied by V_{IF} if the input pins are pulled up to an external source.

Alternate Power Supply Configuration Option

I/O Interface Using 3.3V

In systems where the I/O interface utilizes a 3.3V USB controller, an alternate solution is shown in Figure 7. No extra components are required; however, the load on V_{TRM} must not exceed 10mA.

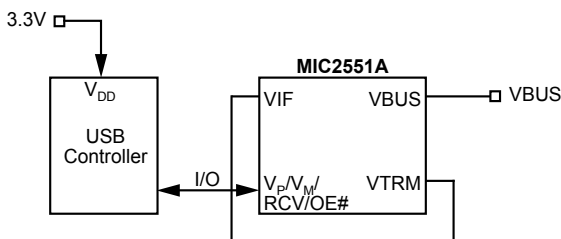

Figure 7. I/O Interface Using 3.3V

Signal Amplitude Respective to V_{IF}

When operating the MIC2551A, it is necessary to provide input signals which do not exceed $V_{IF} + 0.3V$.

Suspend

When the suspend pin (SUS) is high, power consumption is reduced to a minimum. V_{TRM} is not disabled. RCV, V_P and V_M are still functional to enable the device to detect USB activity. For minimal current consumption in suspend mode, it is recommended that $OE# = 1$, and $SPD = 0$.

Speed

The speed pin (SPD) sets D+/D- output edge rates by increasing or decreasing biasing current sources within the output drivers. For low speed, $SPD = 0$. For full speed, $SPD = 1$. By setting $SPD = 0$ during idle periods, in conjunction with suspend (SUS), the lowest quiescent current can be obtained. However, designers must provide a 300ns delay between changing SPD from 0 to 1 and transmission of data at full speed. This delay ensures the output drivers have arrived at their proper operating conditions. Failure to do so can result in leading edge distortion on the first few data bits transmitted.

Non-Multiplexed Bus

In order to save pin count for the USB logic controller interface, the MIC2551A was designed with V_P and V_M as bi-directional pins. To interface the MIC2551A with a non-multiplexed data bus, resistors can be used for low cost isolation, as shown in Figure 8.

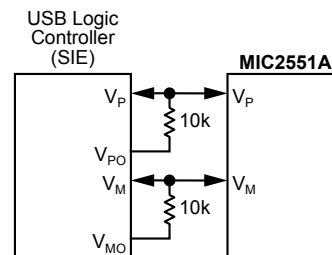

Figure 8. MIC2551A Interface to Non-Multiplexed Data Bus

Configuration Mode	VBUS/VTRM	VIF	Notes
Normal	Connected	Connected	Normal supply configuration and operation.
Disconnect (D+/D-sharing)	Open	Connected	VP/VM are HIGH outputs, RCV is LOW. With OE# = 0 and SUS = 1, data lines may be driven with external devices up to 3.6V. With D+, D- floating, I_{IF} draws less than 1 μ A.
Disconnect	Ground	Connected	VP/VM are HIGH outputs, RCV is LOW. With D+, D- floating, I_{IF} draws less than 1 μ A.
Disable Mode	Connected	Open	Logic controlled input pins are Hi-Z. No communication is possible until interface voltage is restored.
Unpowered	Connected	Ground	Inoperative

Table 1. Power Supply Configuration

PCB Layout Recommendations

Although the USB standard and applications are not based in an impedance-controlled environment, a properly designed PCB layout is recommended for optimal transceiver performance. The suggested PCB layout hints are as follows:

- Match signal line traces (VP/VM, D+, D-) to 40ps, approximately one-third inch if possible. FR-4 PCB material propagation is about 150ps/inch, so to minimize skew try to keep VP/VM, D+/D- traces as short as possible.
- For every signal line trace width (w), separate the signal lines by 1.5 – 2 widths. Place all other traces at >2 widths from all signal line traces.
- Maintain the same number of vias on each differential trace, keeping traces approximately at same separation distance along the line.
- Control signal line impedances to $\pm 10\%$.
- Keep R_S as close to the IC as possible, with equal distance between R_S and the IC for both D+ and D-.

Package Information

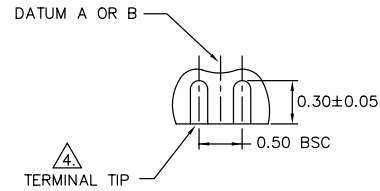
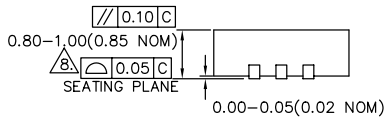
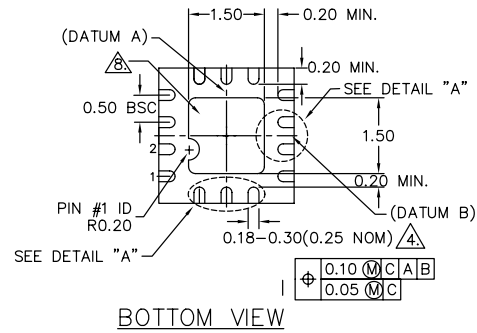
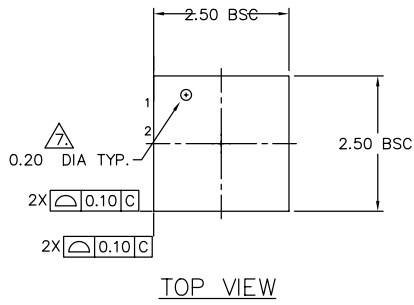

14-Pin MLF® (ML)

MICREL INC. 2180 FORTUNE DRIVE SAN JOSE, CA 95131 USA
 TEL + 1 (408) 944-0800 FAX + 1 (408) 474-1000 WEB <http://www.micrel.com>

This information furnished by Micrel in this data sheet is believed to be accurate and reliable. However no responsibility is assumed by Micrel for its use. Micrel reserves the right to change circuitry and specifications at any time without notification to the customer.

Micrel Products are not designed or authorized for use as components in life support appliances, devices or systems where malfunction of a product can reasonably be expected to result in personal injury. Life support devices or systems are devices or systems that (a) are intended for surgical implant into the body or (b) support or sustain life, and whose failure to perform can be reasonably expected to result in a significant injury to the user. A Purchaser's use or sale of Micrel Products for use in life support appliances, devices or systems is a Purchaser's own risk and Purchaser agrees to fully indemnify Micrel for any damages resulting from such use or sale.