

P	LTR	DESCRIPTION	DATE	DWN	APVD
	C1	REVISED PER ECO-11-007905	15APR2011	HMR	CR
	D	PCN-21-107524	12MAY2022	SCB	SS

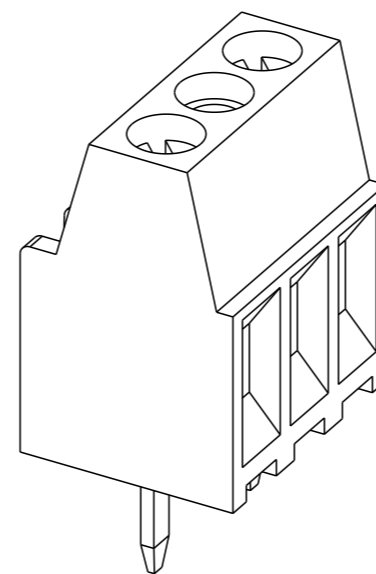

282835-2 AS SHOWN

- 1 MATERIALS AND FINISH
HOUSING: PA 6-6, UL 94-V0, COLOR GREEN.
CLAMP: BRASS, NICKEL PLATED.
TERMINAL: BRASS, TIN PLATED.
CLAMPING SCREW: M1.6, STAINLESS STEEL.
- 2 SUITABLE FOR 1,6-2,4mm PC BOARD THICKNESS.
- 3 CONNECTION POWER
SOLID WIRE: 0,03-1mm² (17AWG).
STRANDED WIRE: 0,03-0,75mm² (18AWG).
- 4 RECOGNIZED UNDER THE COMPONENT PROGRAM OF UNDERWRITERS LABORATORIES INC. FILE N° E60677.
- 5 NOT CUMULATIVE TOLERANCE.
- 6 TORQUE: 1.73 in-lbs MAX

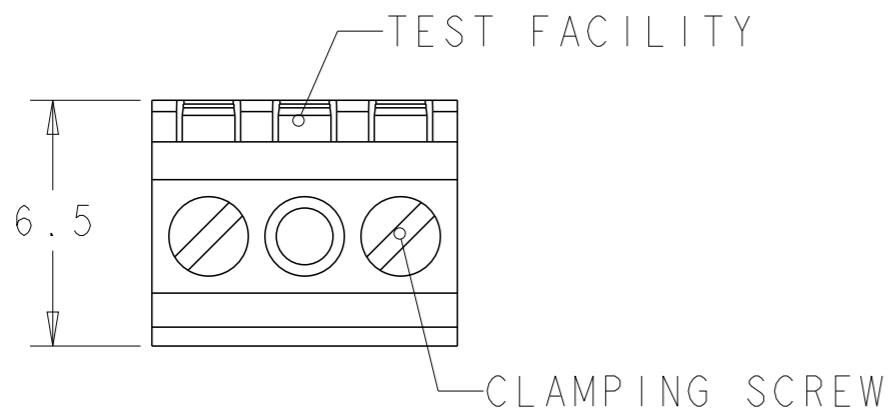
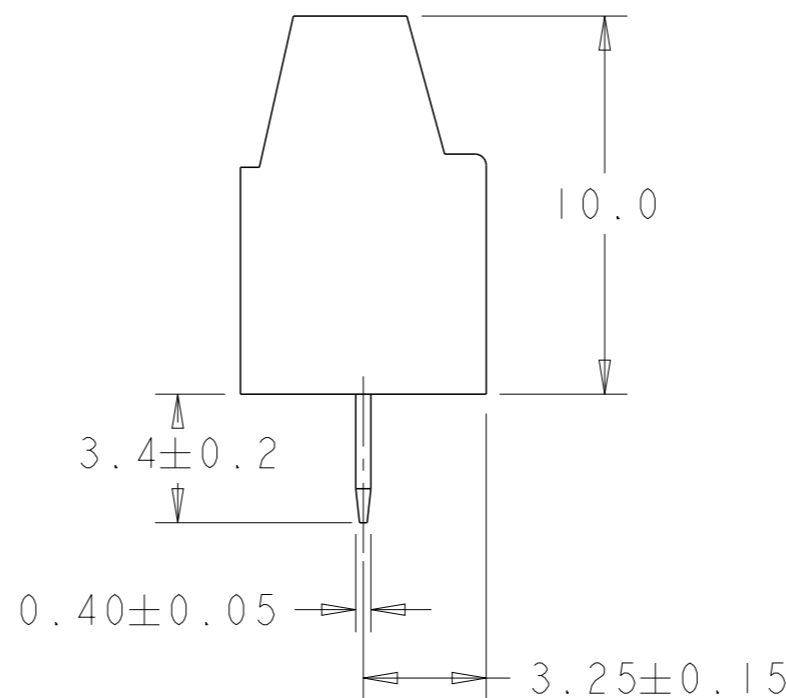
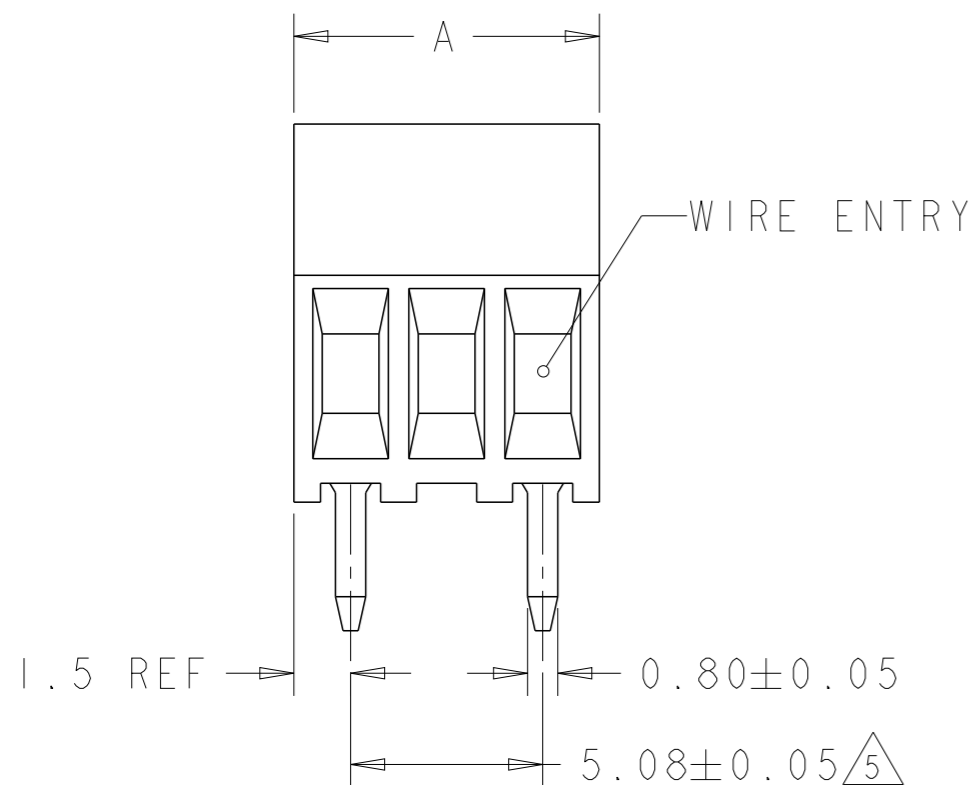

28.40	6	282835-6
23.32	5	282835-5
18.24	4	282835-4
13.16	3	282835-3
8.08	2	282835-2
DIM. A	N° OF POS.	PART NUMBER

RECOMMENDED PC BOARD LAYOUT

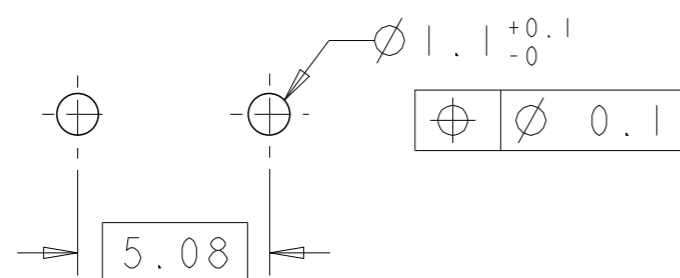

THIS DRAWING IS A CONTROLLED DOCUMENT.

DIMENSIONS:
mm

TOLERANCES UNLESS OTHERWISE SPECIFIED:

0 PLC ±
1 PLC ±.3
2 PLC ±.25
3 PLC ±
4 PLC ±
ANGLES ±2

MATERIAL

FINISH

DWN 15AUG2001

E. ZANOLINI

CHK 15AUG2001

D. BIEVENOUR

APVD 15AUG2001

D. BIEVENOUR

PRODUCT SPEC

108-20166

APPLICATION SPEC

114-20079

WEIGHT

-

NAME
TERMINAL BLOCK PCB MOUNT
SIDE ENTRY WIRE
5.08mm PITCH

SIZE CAGE CODE DRAWING NO RESTRICTED TO

A300779 C-282835

CUSTOMER DRAWING

SCALE 5:1

SHEET 1 OF 1 REV D