

## General Description

The AOZ8204 is a transient voltage suppressor diode array designed to protect data lines from high transient conditions and ESD. This state-of-the-art device utilizes AOS leading edge Trench Vertical Structure [TVS]<sup>2</sup>™ technology for superior clamping performance.

This device incorporates four TVS diodes in a single package. Due to the flexibility of the design, the package can be configured as a two channel bidirectional TVS array. During transient conditions, the TVS diodes direct the transient to ground. They may be used to meet the ESD immunity requirements of IEC 61000-4-2, Level 4 ( $\pm 15\text{kV}$  air,  $\pm 8\text{kV}$  contact discharge).

The AOZ8204 comes in an RoHS compliant DFN package and is rated over a  $-40^{\circ}\text{C}$  to  $+85^{\circ}\text{C}$  ambient temperature range.

The very small  $1.6 \times 1.6\text{mm}$  DFN package makes it ideal for applications where PCB space is a premium. The small size and high ESD protection makes it ideal for protecting high speed video and data communication interfaces.

## Features

- ESD protection for high-speed data lines:
  - Exceeds: IEC 61000-4-2 (ESD)  $\pm 30\text{kV}$  (air),  $\pm 30\text{kV}$  (contact)
  - Human Body Model (HBM)  $\pm 30\text{kV}$
- Trench Vertical Structure [TVS]<sup>2</sup>™ based technology used to achieve excellent ESD clamping performance
- Small package saves board space
- Low insertion loss
- Protects four I/O lines
- Low clamping voltage
- Low operating voltage:  $5.0\text{V}$

## Applications

- Portable handheld devices
- Keypads, data lines
- Notebook computers
- Digital Cameras
- Portable GPS
- MP3 players



## Typical Application

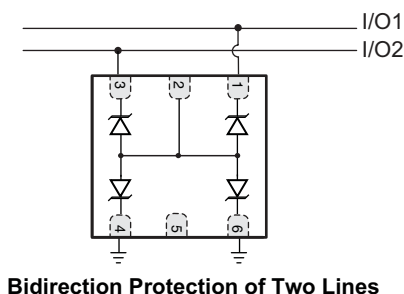
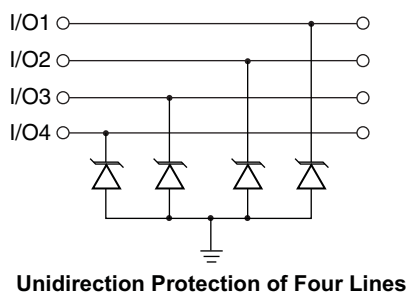

## Pin Configuration

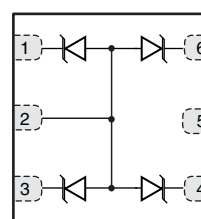

Top View

## Ordering Information

Part Number	Ambient Temperature Range	Package	Environmental
AOZ8204DI	-40°C to +85°C	DFN 1.6x1.6	Green Product



AOS Green Products use reduced levels of Halogens, and are also RoHS compliant. Please visit [www.aosmd.com/media/AOSGreenPolicy.pdf](http://www.aosmd.com/media/AOSGreenPolicy.pdf) for additional information.

## Absolute Maximum Ratings

Exceeding the Absolute Maximum ratings may damage the device.

Parameter	Rating
VP – VN	5V
Peak Pulse Current ( $I_{PP}$ ), $t_P = 8/20\mu s$	5A
Storage Temperature ( $T_S$ )	-65°C to +150°C
ESD Rating per IEC61000-4-2, Contact <sup>(1)</sup>	±30kV
ESD Rating per IEC61000-4-2, Air <sup>(1)</sup>	±30kV
ESD Rating per Human Body Model <sup>(2)</sup>	±30kV

### Notes:

- IEC 61000-4-2 discharge with  $C_{Discharge} = 150pF$ ,  $R_{Discharge} = 330\Omega$ .
- Human Body Discharge per MIL-STD-883, Method 3015  $C_{Discharge} = 100pF$ ,  $R_{Discharge} = 1.5k\Omega$ .

## Maximum Operating Ratings

Parameter	Rating
Junction Temperature ( $T_J$ )	-40°C to +125°C

## Electrical Characteristics

Symbol	Parameter	Conditions	Min.	Typ.	Max.	Units
$V_{RWM}$	Reverse Working Voltage	Between any I/O pin to Ground <sup>(3)</sup>			5.0	V
$V_{BR}$	Reverse Breakdown Voltage	$I_T = 1mA$ , between any I/O pin to Ground <sup>(4)</sup>	6.0			V
$I_R$	Reverse Leakage Current	$V_{RWM} = 5V$ , between any I/O pin to Ground			0.1	$\mu A$
$V_F$	Diode Forward Voltage	$I_F = 15mA$		0.7	1	V
$V_{CL}$	Channel Clamp Voltage Positive Transients Negative Transient	$I_{PP} = 15A$ , $t_P = 100ns$ , any I/O pin to Ground			7.0 -6.75	V V
	Channel Clamp Voltage Positive Transients Negative Transient	$I_{PP} = 25A$ , $t_P = 100ns$ , any I/O pin to Ground			7.50 -10.25	V V
$C_j$	Junction Capacitance	$V_R = 0V$ , $f = 1MHz$ , any I/O pin to Ground		15	17	pF

### Notes:

- The working peak reverse voltage,  $V_{RWM}$ , should be equal to or greater than the DC or continuous peak operating voltage level.
- $V_{BR}$  is measured at the pulse test current  $I_T$ .

## Typical Performance Characteristics

**Clamping Voltage vs. Peak Pulse Current**  
(tperiod = 100ns, tr = 1ns)

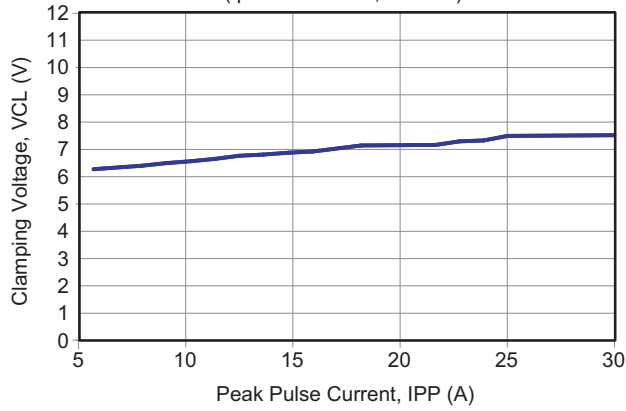

**Clamping Voltage vs. Current**  
(tperiod = 100ns, tr = 1ns)

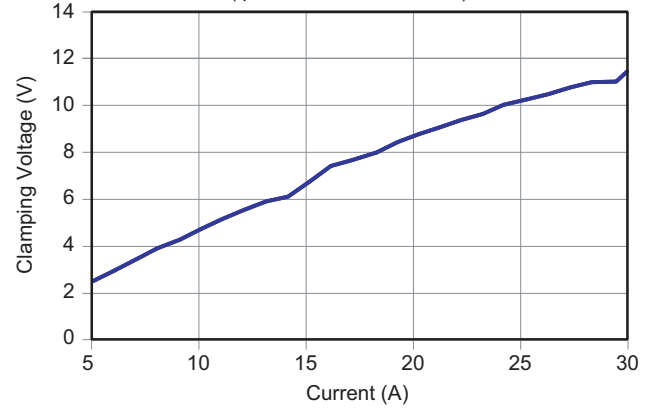

**Capacitance vs. Reverse Bias**

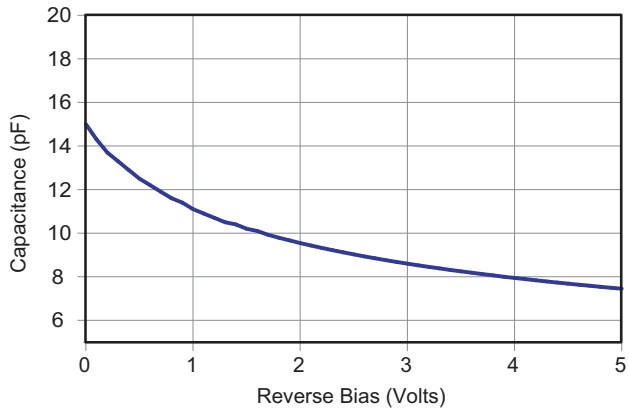

## Applications Information

### Device Connection for Protection of Four Data Lines

These devices are designed to protect up to four unidirectional data lines. The device is connected as follows.

- Unidirectional protection of four I/O lines is achieved by connecting pins 1, 3, 4, and 6 to the data lines. Connect pin 2 to ground. The ground connection should be made directly to the ground plane for best results. The path length is kept as short as possible to reduce the effects of parasitic inductance in the board traces.

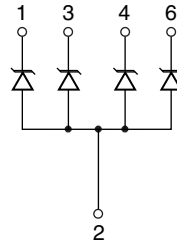

Circuit Diagram

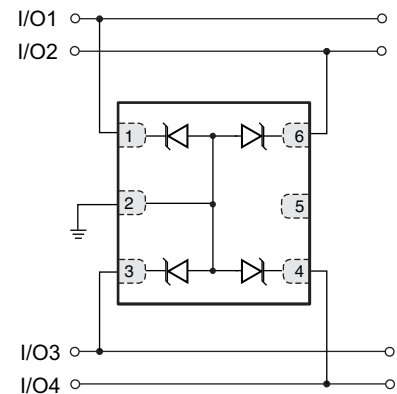

Protection of Four Unidirectional Lines

### Device Connection for Protection of Two Bidirectional Data Lines

These devices are designed to protect up to two bidirectional data lines. The device is connected as follows.

- Bidirectional protection of two I/O lines is achieved by connecting pins 1 and 3 to the data lines. Connect pin 4 and 6 to ground. The ground connection should be made directly to the ground plane for best results. The path length is kept as short as possible to reduce the effects of parasitic inductance in the board traces.

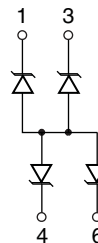

Circuit Diagram

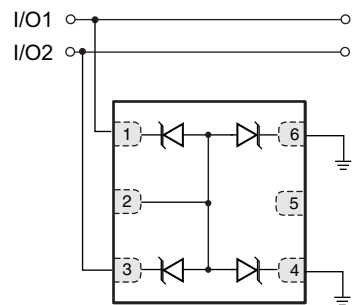

Protection of Two Bidirectional Lines

### Circuit Board Layout Recommendations for Suppression of ESD

Good circuit board layout is critical for the suppression of ESD induced transients. The following guidelines are recommended:

- Place the TVS near the input terminals or connectors to restrict transient coupling.
- Minimize the path length between the TVS and the protected line.
- Minimize all conductive loops including power and ground loops.
- The ESD transient return path to ground should be kept as short as possible.
- Never run critical signals near board edges.
- Use ground planes whenever possible.

Package Dimensions, DFN 1.6 x 1.6, 6L

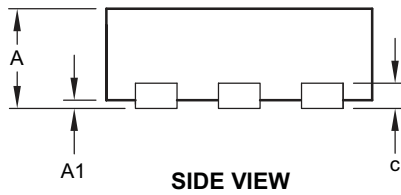
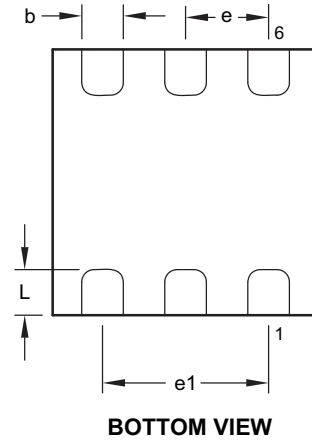
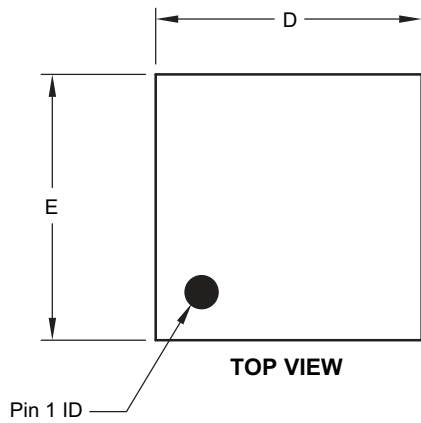

RECOMMENDED LAND PATTERN

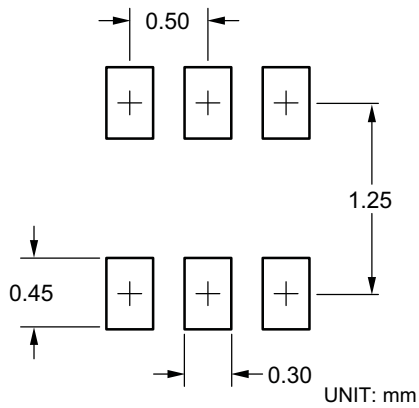

Dimensions in millimeters

Symbols	Min.	Nom.	Max.
A	0.50	0.55	0.60
A1	0.00	0.02	0.05
b	0.22	0.25	0.28
c	1.52 REF.		
D	1.55	1.60	1.65
E	1.55	1.60	1.65
e	0.50 BSC		
e1	1.0 REF		
L	0.225	0.275	0.325

Notes:

1. Dimensions and tolerancing conform to ASME Y14.5M-1994.
2. All dimensions are in millimeters.

### Tape and Reel Dimensions, DFN 1.6 x 1.6, 6L

#### Carrier Tape

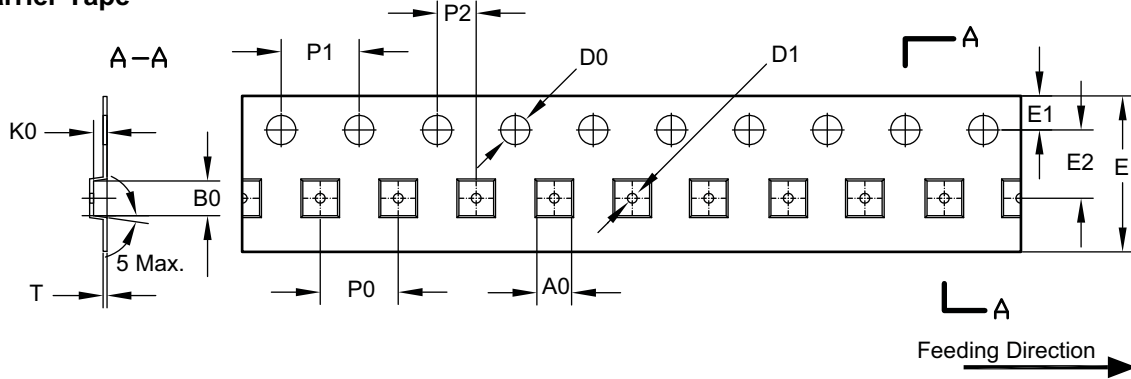

UNIT: mm

Package	A0	B0	K0	D0	D1	E	E1	E2	P0	P1	P2	T
DFN 1.6x1.6	1.78 ±0.05	1.78 ±0.05	0.69 ±0.05	∅1.50 ±0.10	∅0.50 ±0.05	8.00 +0.30 / -0.10	1.75 ±0.10	3.50 ±0.05	4.00 ±0.10	4.00 ±0.10	2.00 ±0.05	0.20 ±0.02

#### Reel

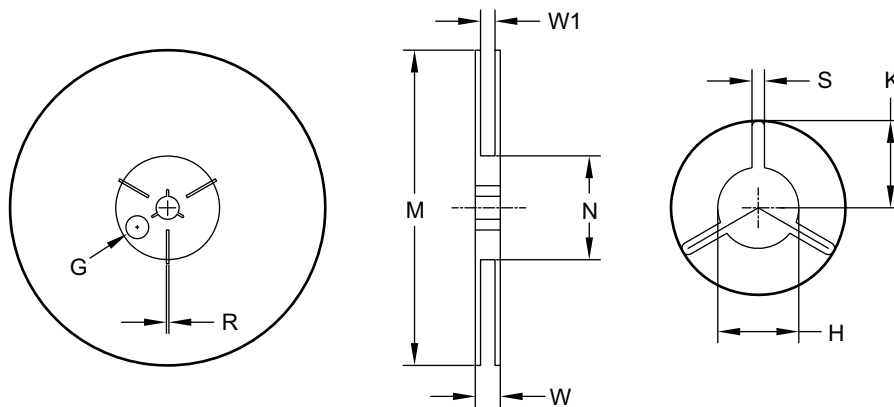

UNIT: mm

Tape Size	Reel Size	M	N	W	W1	H	S	K	E	R
8mm	∅178	∅178.0 ±1.0	∅60.0 ±1.0	11.80 ±0.5	9.0 ±0.5	∅13.0 +0.5 / -0.2	2.40 ±0.10	10.25 ±0.2	∅9.8	—

#### Leader / Trailer & Orientation

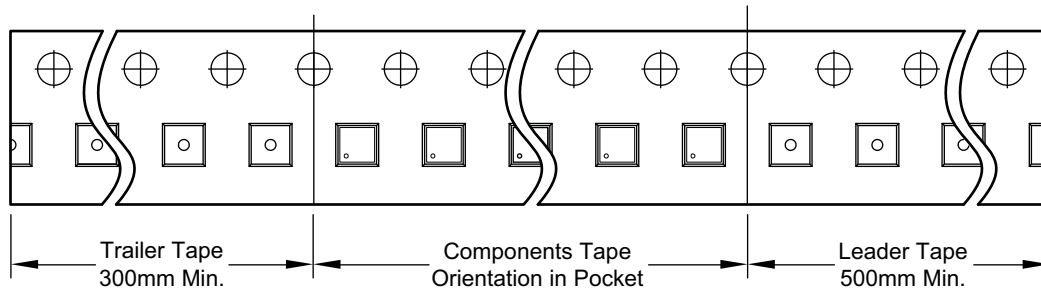

**Part Marking**

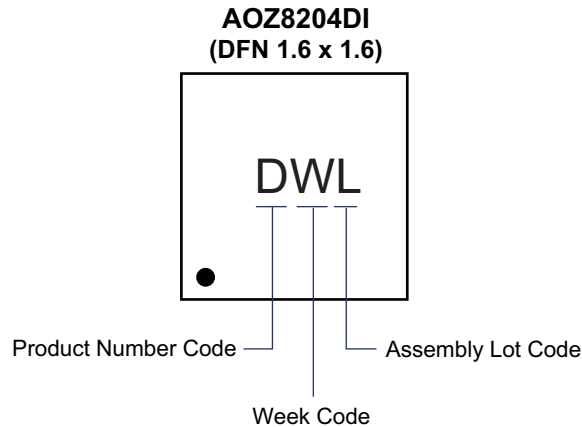

**LEGAL DISCLAIMER**

Alpha and Omega Semiconductor makes no representations or warranties with respect to the accuracy or completeness of the information provided herein and takes no liabilities for the consequences of use of such information or any product described herein. Alpha and Omega Semiconductor reserves the right to make changes to such information at any time without further notice. This document does not constitute the grant of any intellectual property rights or representation of non-infringement of any third party’s intellectual property rights.

**LIFE SUPPORT POLICY**

ALPHA AND OMEGA SEMICONDUCTOR PRODUCTS ARE NOT AUTHORIZED FOR USE AS CRITICAL COMPONENTS IN LIFE SUPPORT DEVICES OR SYSTEMS.

As used herein:

- |   |   |
|---|---|
| <p>1. Life support devices or systems are devices or systems which, (a) are intended for surgical implant into the body or (b) support or sustain life, and (c) whose failure to perform when properly used in accordance with instructions for use provided in the labeling, can be reasonably expected to result in a significant injury of the user.</p> | <p>2. A critical component in any component of a life support, device, or system whose failure to perform can be reasonably expected to cause the failure of the life support device or system, or to affect its safety or effectiveness.</p> |
|---|---|