

RECOMMENDED
CABLE STRIPPING DIM'S

REV.	DATE	ECR NO.	DESCRIPTION
NC		XXXX	INITIAL RELEASE
A	04/31/03	XXXX	UPDATE DRAWING FORMAT
B	11/13/06	XXXX	MODIFY BARREL O.D. TO 2.70 MM
C	04/27/08	100011	REVISE FERRULE I.D. TO 3.20 MM AND O.D. TO 3.9 MM
D	11/26/12	2405	IMPROVE ELECTRICAL PERFORMANCE, UPDATE DRAWING FORMAT

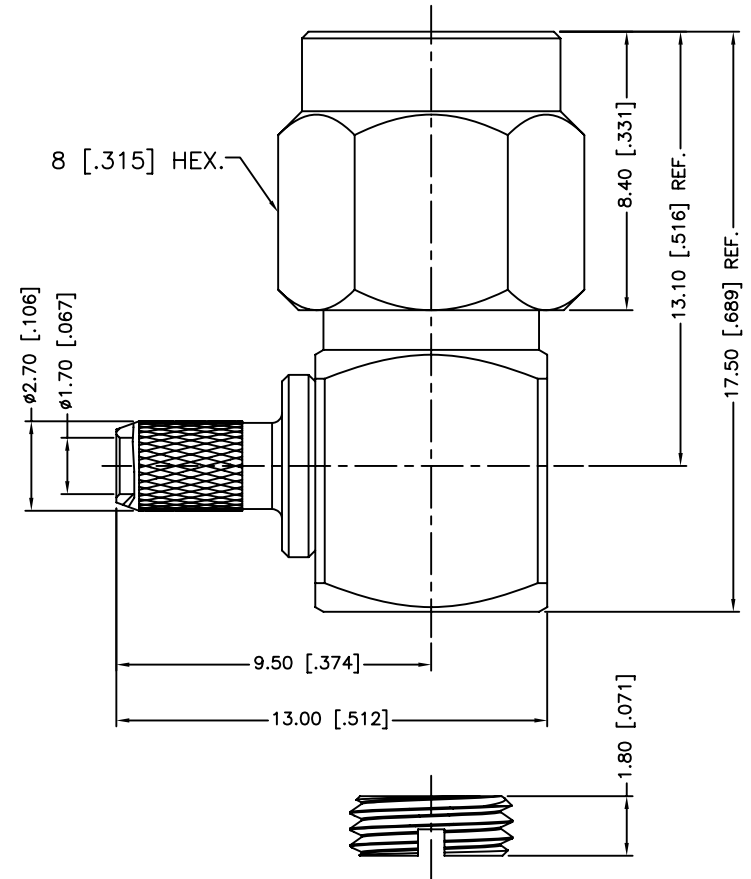

1. IMPEDANCE: 50 OHM
2. FREQUENCY RANGE: DC 0-3 GHz
3. VSWR (RETURN LOSS): 1.2 MAX.
4. INSERTION LOSS: <math><0.3</math> dB TO <math><0.7</math> dB @ 0-3 GHz
5. DIELECTRIC WITHSTANDING VOLTAGE: 1000 VRMS, MIN.
6. DURABILITY: 500 CYCLES MIN.
7. TEMPERATURE RANGE: -65°C TO +165°C
8. CRIMPED FERRULE
HEX CRIMP SIZE .128"

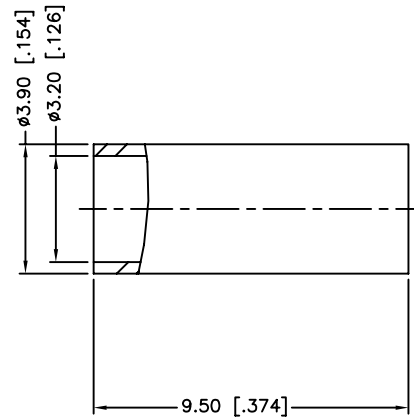
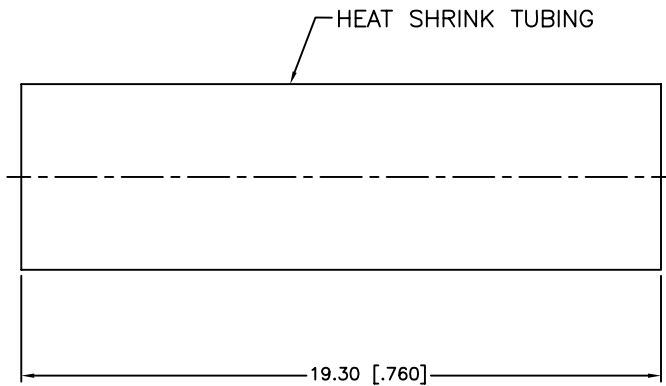
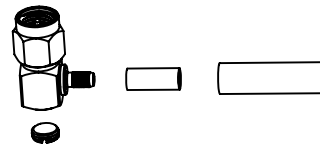

9	HEAT SHRINK TUBING		BLACK	1
8	FERRULE	BRASS	GOLD	1
7	COVER	BRASS	GOLD	1
6	HOUSING WITH BARREL	BRASS	GOLD	1
5	INSULATOR	PTFE	NATURAL	1
4	CONTACT PIN	BRASS	GOLD	1
3	RETAINER RING	SUS 304	NATURAL	1
2	GASKET	SILICONE RUBBER	RED	1
1	SHELL	BRASS	GOLD	1
	DESCRIPTION	MATERIAL	FINISH	QTY

UNLESS OTHERWISE SPECIFIED DIMENSIONS ARE IN MILLIMETERS. DIMENSIONS IN [] ARE IN INCHES AND FOR CUSTOMER REFERENCE ONLY.

UNLESS OTHERWISE SPECIFIED TOLERANCES FOR MILLIMETERS ARE:
0.5 - 8mm ± 0.20mm
8 - 30mm ± 0.40mm
30 - 120mm ± 0.50mm

UNLESS OTHERWISE SPECIFIED TOLERANCES FOR INCHES ARE:
.020 - .315 = ± 0.007"
.315 - 1.180 = ± 0.015"
1.180 - 4.724 = ± 0.020"

DO NOT SCALE DRAWING

APPROVALS	DATE
DRAWN M.ZHANG	11/26/12
CHECKED	
ISSUED	
SHEET 1 OF 1	
CAD FILE	C:/CONNEX/132123.DWG

Amphenol Connex

PART DESCRIPTION			
SMA R/A CRIMP PLUG (FOR RG-174/U,188A/U,316/U)			
PART NO.		132123	
DWG. NO.	132123.DWG	REV. D	SCALE A
			SCALE NA