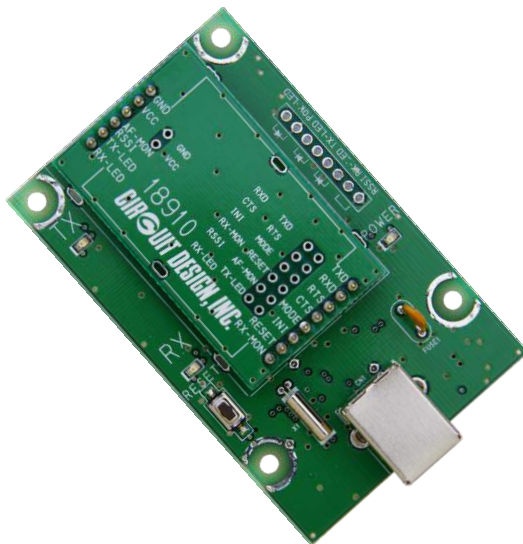
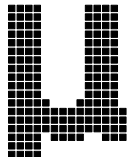

Embedded low power radio modem **MU-4****MU-4 USB Interface Board****MU4-USBIF****Operation Guide**

Version 1.0 (Sep. 2020)

CIRCUIT DESIGN, INC.,7557-1 Hotaka, Hotaka-machi,
Minamiazumi, Nagano 399-8303 JAPAN

Tel: +81-(0)263-82-1024

Fax: +81-(0)263-82-1016

E-mail: info@circuitdesign.jpWeb site: <https://www.cdt21.com/>

Contents

Chapter 1 The MU4-USBIF	2
1.1 Outline	2
1.2 System Requirements	3
1.3 Product Name and Part Number	4
1.4 Board and contents	4
Chapter 2 The MU4-USB	5
2.1 Part Names and Functions	5
2.2 Block Diagram	6
2.3 Main Specifications	7
2.4 Channel Table	7
2.5 External Dimensions	8
2.6 Circuit Diagram	9
Chapter 3 How to Use the MU4-USB	10
3.1 System Configuration Example	10
3.2 The USB driver	11
3.3 Resetting	11
3.4 Initializing	11
Chapter 4 How to Design a User System	12
4.1 Embedding the Product	12
4.2 The Antenna	13
4.3 Regulatory Compliance	13
4.4 Cautions	13
Chapter 5 How to Develop a Program	13
Chapter 6 When Designing an Original System	14
6.1 The Circuits	14
6.2 The USB Driver	14
6.3 Directly Controlling the USB Chip	15

Chapter 1 The MU4-USBIF

1.1 Outline

The MU-4 USB interface board, MU4-USBIF is a development board for planning radio system applications with a USB interface connection function that use the embedded low power radio modem MU-4. Purchasing the board enables you to begin evaluating communication with the MU-4 immediately.

The board uses the FTDI FT8U232MB that has a protocol conversion function to convert between the USB and UART interfaces. Since the control program created by the user accesses the host COM port, users can apply their fund of knowledge of RS232C technology.

The board with MU-4 can be controlled using simple dedicated commands, so that the developer can concentrate on designing the protocols for transmitting and receiving data, without needing to be aware of control of the radio component.

Power to the USB interface board MU4-USBIF is supplied from the USB interface, so an external power supply is not necessary.

*1 Before using this product, it is first necessary to install the VCP driver. For installation, refer to the information on installing the driver found in the setup launcher in the zip file.

1.1.1 The MU4-USB

In this operation guide, for the sake of convenience, the MU-4 USB interface board MU4-USBIF with the embedded low power radio modem MU-4 mounted on it is referred to as the MU4-USB. Before using the board, mount the MU-4 on the MU4-USBIF. When mounting the MU-4, observe the following cautions, and carry out the soldering carefully.

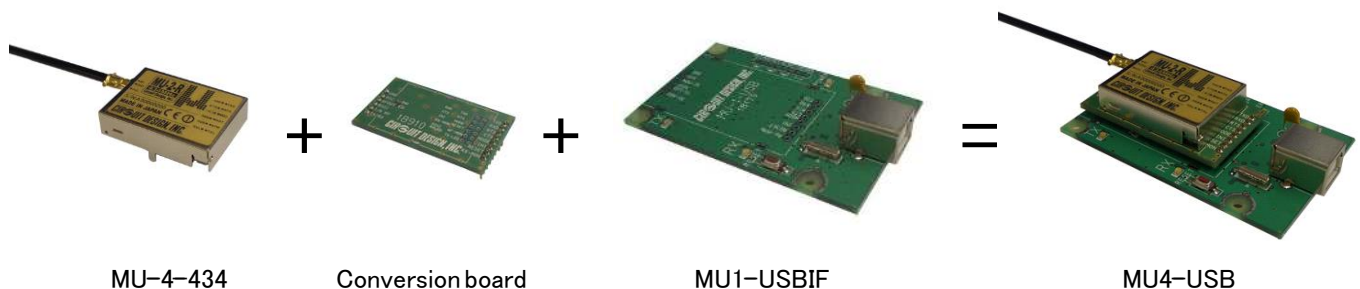

Caution

Cautions for soldering

- Attach the MU-4 unit to the conversion board before mounting it on the MU1-USBIF.
- To prevent damage to the connectors, solder the joints quickly.
- Avoid connection defects.
- In order to prevent damage to the MU-4 and the MU1-USBIF from static electricity, ground yourself before starting work.
- Do not cause short circuits by dripping solder on the board.

Important

The development board does not include module MU-4. Please make sure to order it if needed.

It is not possible simply to replace communication using existing RS232C system equipment connected with a cable, with MU4-USB wireless communication. The hardware and software must be designed specifically for the MU-4.

■ 1.1.2 Explanation of terminology

The meaning of the terminology used in this operation guide is as follows.

1. The “**Evaluation program and driver**” is the zip file that is available from the Circuit Design website, that contains the setup program, Operation Guide and so on.
The program is located on MU-4 documents page.
2. The “**Evaluation Program**” is a program for evaluation of the MU-2-R and series of products, called the MU-2-R Evaluation Software Program MU2-ESP. After installation it is found inside the “Circuit Design” folder that appears on the desktop of your PC. MU-4 is compatible with commands and interface, also can use this program.

■ 1.1.3 Features

- ◆ Power for the MU4-USB is supplied by the USB interface cable.
- ◆ The COM port used is recognized as a VCP *1, and the user need only create a control program for accessing a normal COM port.
- ◆ Circuit diagrams for making user systems are publicly available.
- ◆ The product can be embedded in a case, and can be used for making products for radio control from a PC.
- ◆ Compact size (47 × 78 × 16 mm) fits in a small housing.
- ◆ Features of the MU2-ESP evaluation program;
 1. You can issue all commands for controlling the interface board with module.
 2. There is a test program for checking the communication performance of the interface board with module.
 3. There is an air monitor function for checking the status of radio waves in the field.

*1: Recognized as a VCP (virtual COM port) when the dedicated driver is installed.

■ 1.1.4 Applications

- ◆ Serial data transmission
Energy monitoring, data monitoring devices, handy terminals, barcode readers
- ◆ Telecontrol
Remote control for construction machinery, display devices, motor control, lifters
Remote control of FA equipment
- ◆ Telemetry
Water level monitors for rivers and dams, temperature and humidity gauges, rain gauges, pressure gauges, voltmeters, ammeters

1.2 System Requirements

Systems used with MU4-USBIF must meet the following conditions.

1. OS: Windows 8 and 10
2. Hard disk capacity: 30 MB or more
3. Memory: 64 MB or more

1.3 Product Name and Part Number

Product name: MU-4 USB interface board

Part number: MU4-USBIF

1.4 Board and contents

The board and contents are as follows. First, please check that you have all the items.

■ **1.4.1 Accessories**



MU1-USBIF x 1



Conversion board x 1



Screw(M2.6 x 6mm) x 4
Spacer(10mm) x 4

- | | |
|-----------------------------------|---|
| 1. USB interface board MU1-USBIF | 1 |
| 2. Conversion board | 1 |
| 3. Spacers (used as legs) 10 mm | 4 |
| 4. Screws for spacers M2.6 x 6 mm | 4 |

Chapter 2 The MU4-USB (MU-4 + MU4-USBIF)

2.1 Part Names and Functions

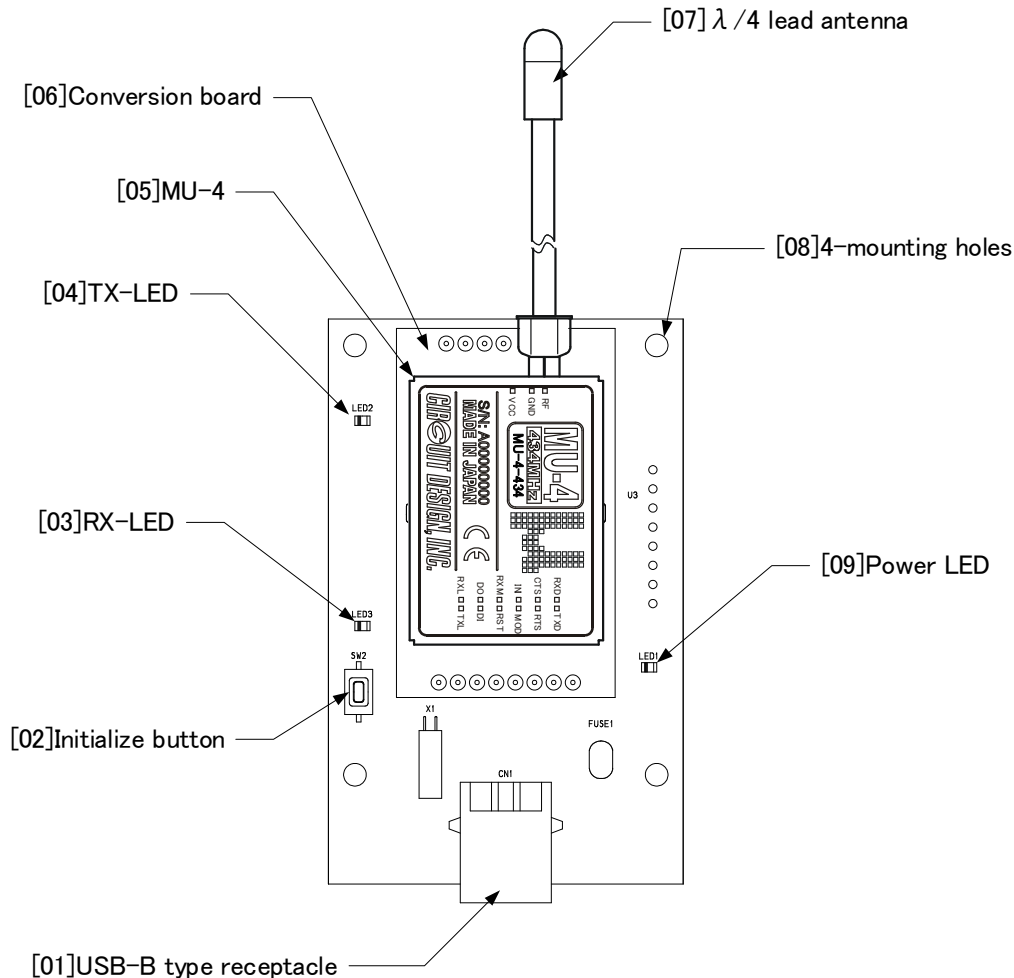

[01] USB-B receptacle: For connecting the double shield USB cable (USB 2.0 High Speed).

[02] Initialize button: Resets the MU-4 mounted on the MU4-USB to the factory default settings. Follow the procedure below.

1. Turn on the power (connect the USB cable) while pressing the initialize button.
2. Release the initialize button and after turning off the power (remove the USB cable), turn the power again (connect the USB cable) after a while (approx. 5 seconds).

[03] RX-LED: On when data is received.

[04] TX-LED: On when data is transmitted.

[05] MU-4: A low power serial data transmission modem.

[06] Conversion board: A board making it possible to fit the pins of the MU-4 into the USB board.

[07] λ/4 lead antenna: A λ/4 long lead antenna. (ANT-LEA-01, ANT-RIG-01-R)

[08] Mounting holes: 3Φ holes for mounting

[09] Power LED: The LED comes on when the USB cable is connected.

2.2 Block Diagram

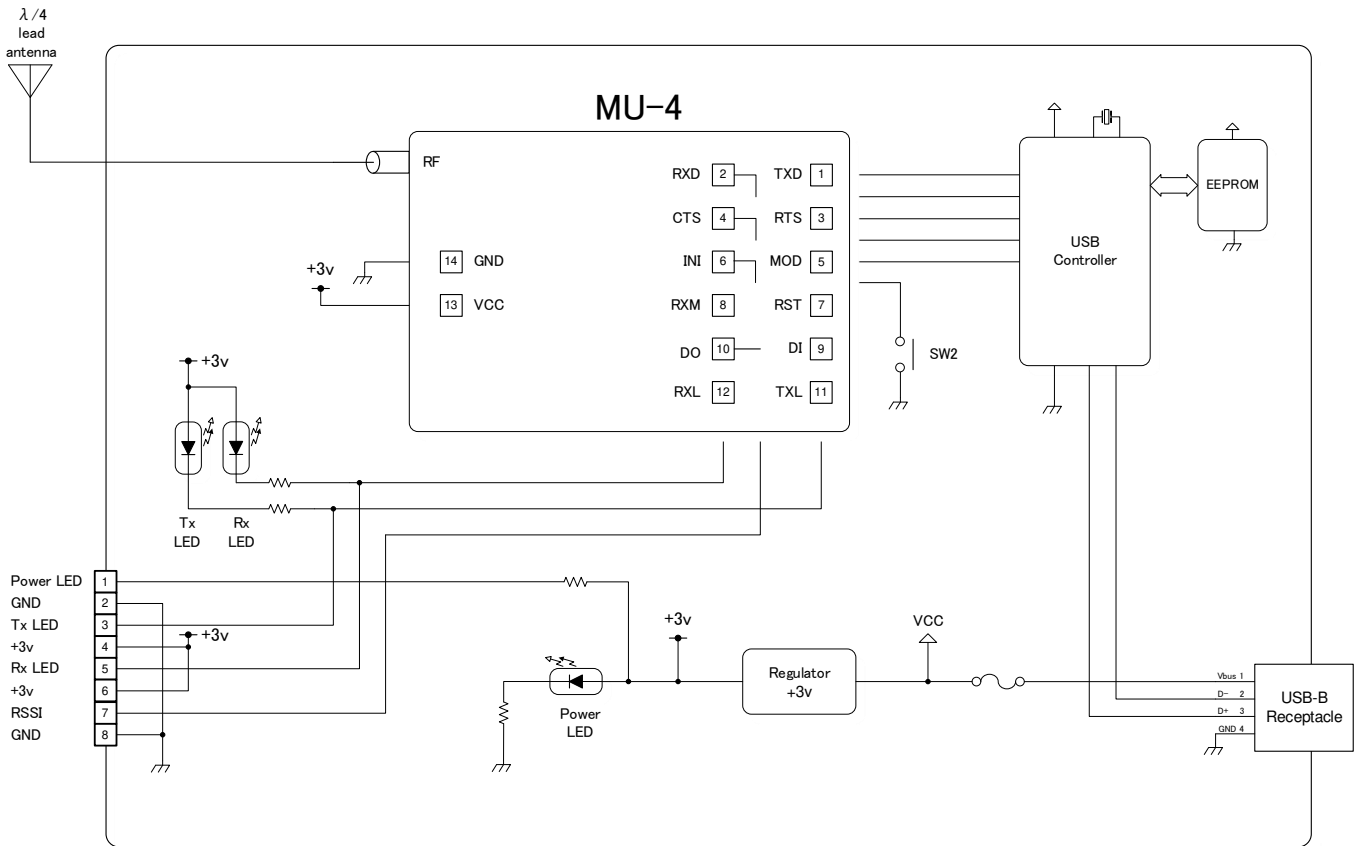

2.3 Main Specifications

■ 2.3.1 General specifications

Parameter	Specification	Unit	Remark
Supply voltage	USB bus power		
Consumption current	Transmitting: 59 / Receiving: 40	mA	USB bus power
Operating temperature	-20 to +65	°C	The range varies with the temperature conditions.
LED indicator	Tx, Rx, Power		
Switch	Initialize		
External dimensions	47 × 78 × 16 (W × D × H)	mm	Including the connector. Not including the antenna.
Unit weight	26	g	

■ 2.3.2 USB interface specifications

Item	Specification
Interface specification	USB Ver. 2.0 Full speed
Receptacle	USB-B type receptacle
Adapter	USB-B type plug

■ 2.3.3 RS232C parameter specifications

Data speed	1,200/2,400/4,800/9,600/19,200/38,400/57,600 bps
Flow control	RTS/CTS hardware flow control
Other parameters	Data length 8 bits, no parity, 1 or 2 stop bits

2.4 Channel Table

Refer to the operation guide of the MU-4 mounted on the MU4-USBIF for the channel table. The frequency band is shown on the label of the MU-4.

2.5 External Dimensions

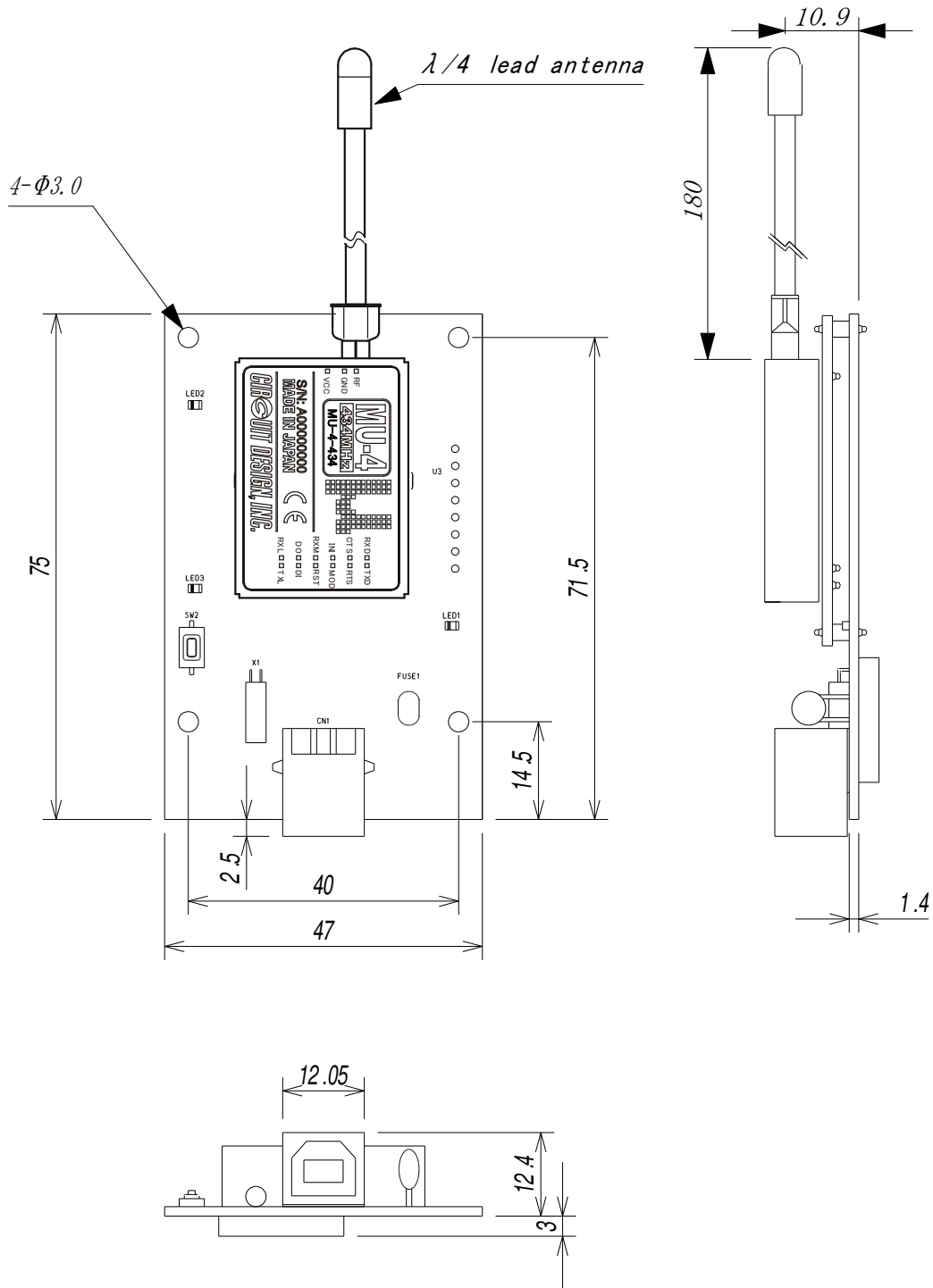

2.6 Circuit Diagram

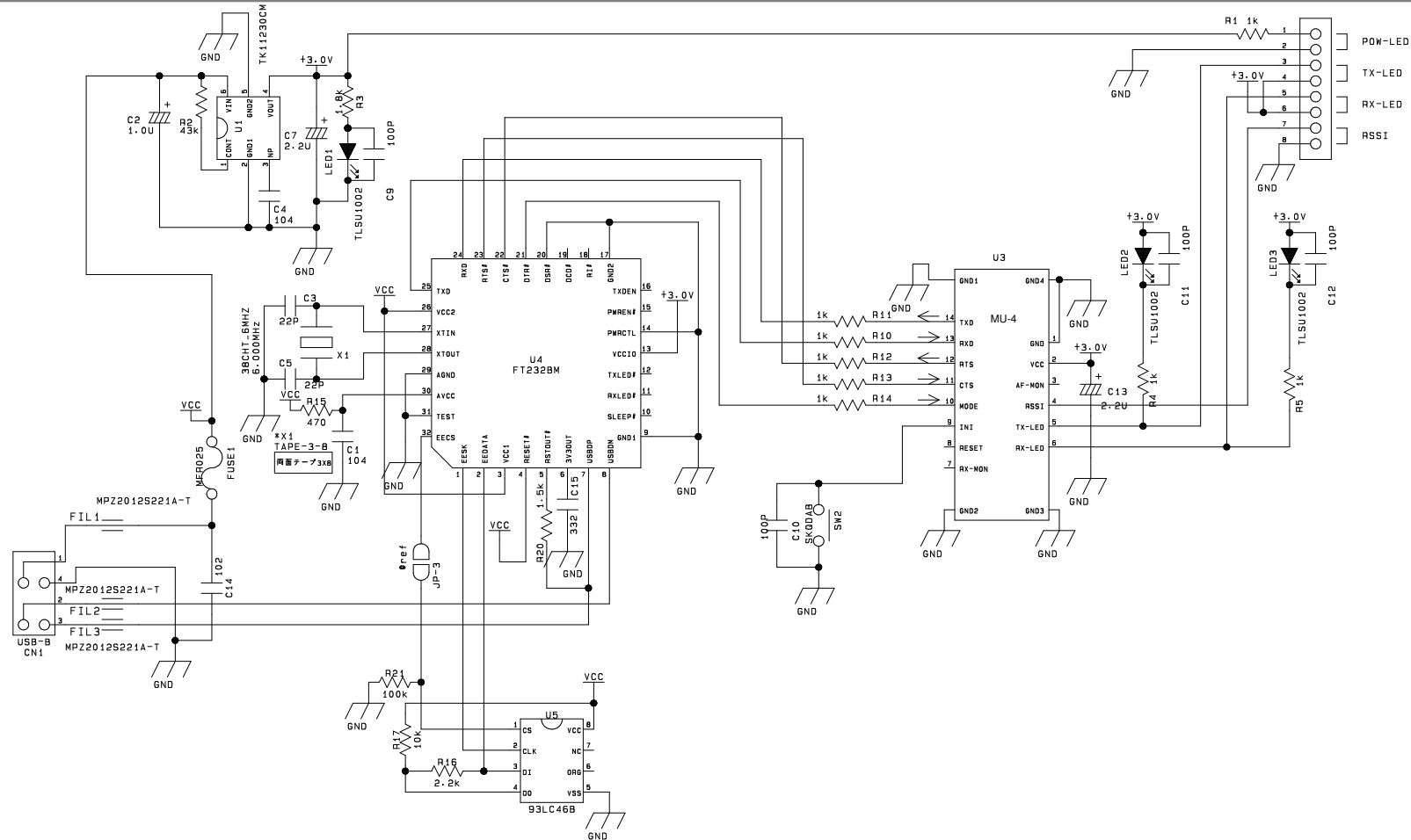

- * When making your circuit board based on this circuit diagram, pay due attention to high frequency noise around the USB chip and from the interface.
1. Exercise caution in placement of the MU-4 and USB chip. In addition, there are cases where shielding is necessary around the chip.
 2. Add a noise filter to the USB interface signal wire.
 3. Ensure a sufficiently large ground pattern for the MU-4. In addition, provide shielding for the signal wire too.

Chapter 3 How to Use the MU4-USB

The MU4-USB (MU-4 + MU4-USBIF) uses a virtual COM port. Since it is basically used in the same way as the MU-4, refer to “Chapter 4 How to Use the MU-4” in the MU-4 operation guide.

3.1 System Configuration Example

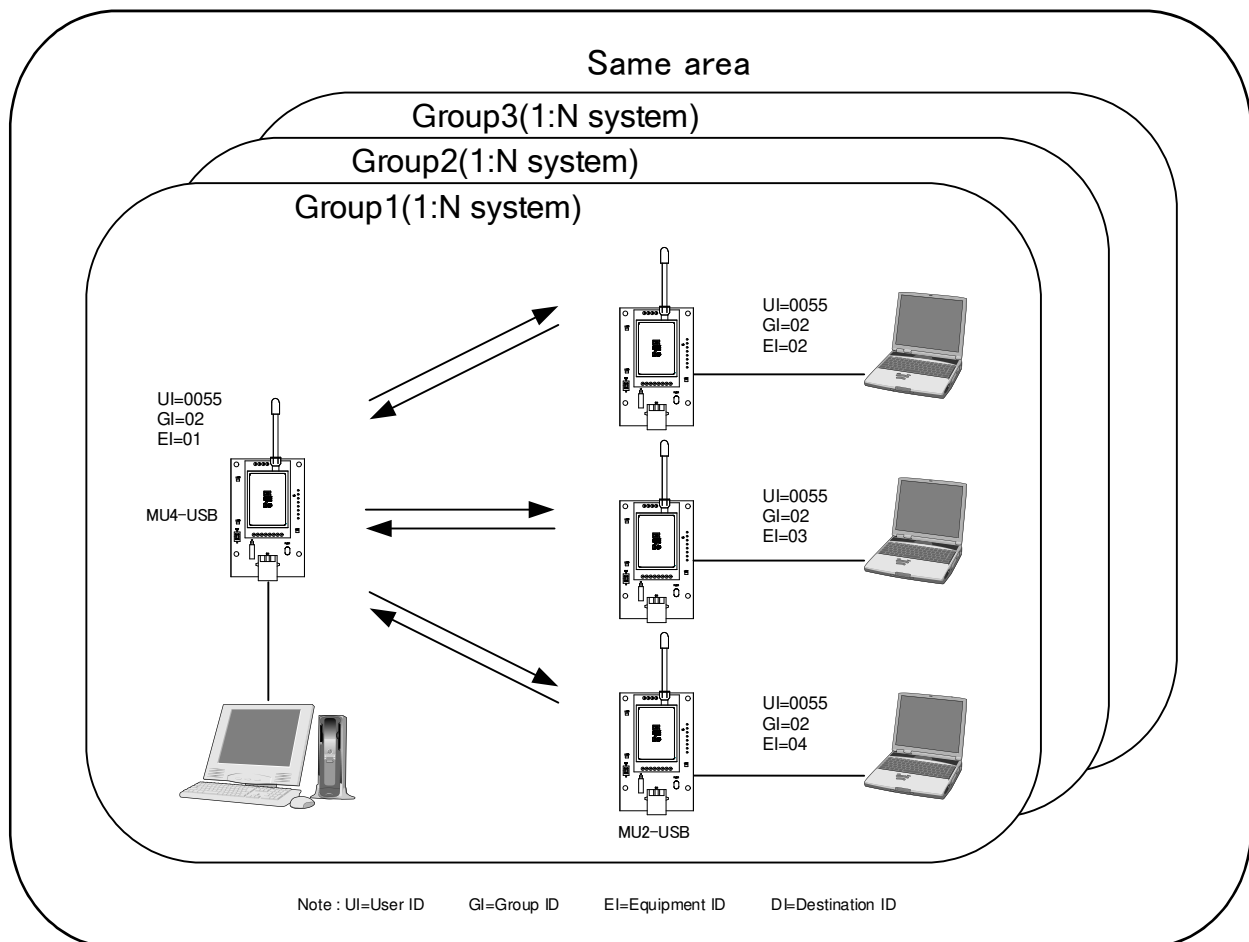

3.2 The USB Driver

3.2.1 Installing the USB Driver

The MU4-USB supports Windows plug and play. Connect the double shield USB cable (USB 2.0 High Speed) to the unit, then connect the cable to the computer. The install USB driver window opens automatically. Follow the instructions to install the driver. The MU4-USB driver file is located in the zip file [USB_Driver] folder. The device may recognize as MU1-UIK or MU2-UIK. When installing the driver with Windows 8 or 10, please refer to the application note on the website.

3.2.2 Uninstalling the USB Driver



To uninstall the driver, use the FTCClean in the setup disk. Input 13A7 as the vendor ID and 1004 as the product ID to remove the driver. The FTCClean is located in the "FTCClean" folder in the "MU2_USB_Driver" folder.



Caution

Be sure to disconnect the MU4-USB from the computer first. If you uninstall the driver with the MU4-USB connected to the computer, the Windows registry will not be deleted normally. This may result in problems when you next install the driver.

3.2.3 Checking that the USB Driver Works

To check that the USB driver works, use the Device Manager. Check that MU2-USB appears in the Properties.

3.3 Resetting

Using the reset command @SR, the MU4-USB can be reset to the settings at the time the power was turned on. The parameters fixed in the EEPROM remain unchanged.

3.4 Initializing

Initialize the unit to the factory default settings if communication with the MU-4 mounted on the MU4-USB is not possible or if you are uncertain of the internal settings.

How to initialize the MU-4

Turn on the power (connect the USB cable) while pressing the initialize button. Then turn the power off (remove the USB cable) and on once again to reset the unit to the default settings. For details, refer to the default values for each command in the MU-4 Operation Guide. The MU-4 can also be initialized with the initialize command @IZ.

Status after initializing

The values of the main parameters after initializing are as follows.

1. Link related parameters
User ID: UI = 0000, Group ID: GI = 00, Equipment ID: EI = 01, Destination ID: DI = 01, Channel = 0 channel
2. UART related parameters
Baud rate = 19,200 bps, parity = none, stop bit = 1
3. Parameters related to internal operation
Mode = command

Chapter 4 How to Design a User System

When embedding the MU4-USB (MU-4 + MU4-USBIF) in a user system, pay due attention to the design of the board and case.

4.1 Embedding the Product

This board is connected to a PC provided with a USB port. Connect the unit to the PC with the dedicated USB cable provided. Power for the product is supplied from the PC through the USB cable.

If you house the product in a case, determine the position of the ground and antenna through a variety of tests. In addition, if you attach LEDs to the case, connect them with inch-pitch through holes with reference to the diagram below.

If you use a USB cable other than the one provided, use a double shield cable (USB 2.0 High Speed). Otherwise, radio waves may not be emitted due to high frequency noise from the USB.

When using USB, pay attention to the total current capacity of the other equipment since it can result in malfunctions. When marketing products that use this product, provide information about the current in your operation guide.

4.1.1 Controlling the MU4-USB with a PC

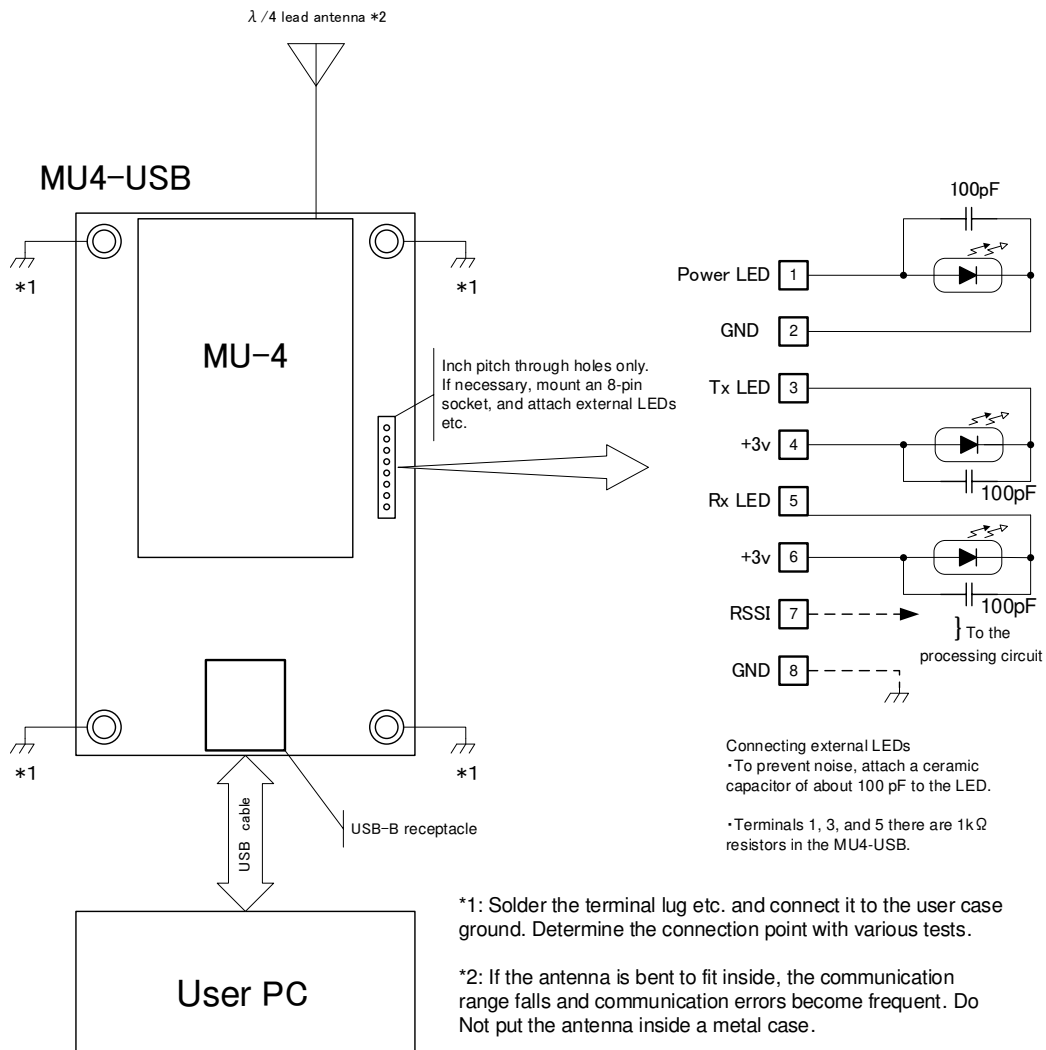

4.2 The Antenna

In systems where a non-directional antenna is required, it is important that the antennas of the transmitting station and target stations stand vertically in order to exploit communication performance to the maximum. If the planes of polarization of the radio waves do not match, receive sensitivity may drop significantly.

Note that if, for reasons peculiar to the equipment, the antenna must be inside the case, communication performance will be very significantly degraded when handled in the ways below, since these methods contravene antenna theory. It is the responsibility of the user to test performance thoroughly when designing equipment.

1. Putting the antenna inside a metal case
2. Wrapping the antenna around the MU4-USB itself
3. Locating the antenna beside the ground pattern of your circuit board
4. Fitting the antenna inside by bending it
5. Cutting the antenna to make it shorter

The antenna of the MU4-USB is a $1/4\lambda$ whip antenna. Whip antennas are antennas that substitute the ground as one end of a dipole antenna. For this reason, the ground has a very important meaning. Although the main unit of the MU2-USB has the function of a ground, in order to exploit its performance fully, connect it to the largest possible ground pattern when mounting it on your circuit board.

In addition, in the case of two-way communication between fixed stations, inclining the whip antenna of the MU-4 forwards may increase its communication range. Carry out tests in the specific environment of use.

4.3 Regulatory Compliance

The MU4-USBIF is a test board that uses an USB interface to interface with external equipment. The MU4-USB is made for test equipment, and is not a stand-alone product. The regulatory compliance assessment of the MU2-USB in accordance with the RE Directive depends on the final product in which the MU4-USB is embedded. Regulatory compliance assessment should be carried out on the responsibility of the manufacturer of the final product.

For details of the CE mark, refer to the MU-4 operation guide.

☞ Point:

The MU-4 radio modem has passed the regulatory compliance assessment in accordance with RE Directive as a stand-alone product, and has received the CE mark.

4.4 Cautions

1. Always use double shield USB cable for connecting the MU4-USB.
2. Devise ways of isolating the MU-4 as far as possible from sources of noise, including noise from other embedded equipment.
3. Arrange the MU4-USB so that it will not be covered by the operator's hand or the like.
4. The MU4-USB does not have a waterproof structure. If the antenna is located outside the main unit, use a structure that prevents water droplets from entering the case.

Chapter 5 How to Develop a Program

The program that controls the MU4-USB (MU-4 + MU4-USBIF) is a program that accesses the COM port. The method of developing a program is basically the same as for the MU-4, except for accessing a virtual COM port. Refer to "Chapter 6 How to Develop a Program" in the MU-4 operation guide.

Chapter 6 When Designing an Original System

When designing an original USB interface system similar to the MU4-USB using the MU-4, bear in mind the items explained below.

6.1 The Circuits

Although the circuit diagram shown in this operation guide is a proper circuit, even when made in accordance with the circuit diagram, it may not perform well due to high frequency noise from the surrounding circuitry. Bear in mind the following when designing circuits.

1. Exercise caution in placement of the MU-4 and USB chip. In addition, there are cases where shielding is necessary around the chip.
2. Add a noise filter to the USB interface signal wire.
3. Ensure a sufficiently large ground pattern for the MU-4. In addition, provide shielding for the signal wire too.

Use a double shield USB cable (USB 2.0 High Speed).

In order to assess the performance of your circuit board, issue the '@RA' command to acquire the RSSI level of the MU-4 and check the level. It is necessary to acquire and assess the level of all the channels. Set a standard lower than the value acquired with the MU4-USB. Here it is convenient to use the air monitor of the MU-4 evaluation program. In order to use the air monitor function, it is necessary to make a design in which the terminals of the MU-4 can be controlled from the outside.

6.2 The USB Driver

If you design an original system with a USB interface, you will need a unique vendor ID. Vendor IDs are obtained from USB-IF. For details, refer to the site below.

USB-IF website URL: <http://www.usb.org/developers/vendor/>

When you have a vendor ID, you can write it to the chip using an EEPROM programmer (MProg or the like) provided by FTDI.

In addition, although you can use the FTDI USB driver, it is necessary to change several of the driver related files in order to make the driver proprietary. Edit the Ftdibus.inf, Ftdiport.inf and Ftdiun2k.ini files in the driver folder to make them apply to your company.

The additions and changes are shown below underlined.
 Example: Vendor ID = 1234, and product ID = 5678

◆ Ftdibus.inf

```
[FtdiHw]
%USB%VID_0403&PID_6001.DeviceDesc%=FtdiBus.NT,USB%VID_0403&PID_6001
%USB%VID_0403&PID_6010&MI_00.DeviceDesc%=FtdiBus.NT,USB%VID_0403&PID_6010&MI_00
%USB%VID_0403&PID_6010&MI_01.DeviceDesc%=FtdiBus.NT,USB%VID_0403&PID_6010&MI_01_
Add %USB%VID_1234&PID_5678.DeviceDesc%=FtdiBus,USB%VID_1234&PID_5678
```

```
[FtdiHw.NTamd64]
%USB%VID_0403&PID_6001.DeviceDesc%=FtdiBus.NTamd64,USB%VID_0403&PID_6001
%USB%VID_0403&PID_6010&MI_00.DeviceDesc%=FtdiBus.NTamd64,USB%VID_0403&PID_6010&MI_00
%USB%VID_0403&PID_6010&MI_01.DeviceDesc%=FtdiBus.NTamd64,USB%VID_0403&PID_6010&MI_01
Add %USB%VID_1234&PID_5678.DeviceDesc%=FtdiBus.NTamd64,USB%VID_1234&PID_5678
```

```
[Strings]
Ftdi="FTDI"
DESC="CDM Driver Package"
DriversDisk="FTDI USB Drivers Disk"
USB%VID_0403&PID_6001.DeviceDesc="USB Serial Converter"
USB%VID_0403&PID_6010&MI_00.DeviceDesc="USB Serial Converter A"
USB%VID_0403&PID_6010&MI_01.DeviceDesc="USB Serial Converter B"
Add USB%VID_1234&PID_5678.DeviceDesc="My New USB Device"
```

◆ Ftdiport.inf

```
[FtdiHw]
%VID_0403&PID_6001.DeviceDesc%=FtdiPort232.NT,FTDIBUS%COMPORT&VID_0403&PID_6001
%VID_0403&PID_6010.DeviceDesc%=FtdiPort2232.NT,FTDIBUS%COMPORT&VID_0403&PID_6010
Add %VID_1234&PID_5678.DeviceDesc%=FtdiPort232,FTDIBUS%COMPORT&VID_1234&PID_5678
```

```
[FtdiHw.NTamd64]
%VID_0403&PID_6001.DeviceDesc%=FtdiPort232.NTamd64,FTDIBUS%COMPORT&VID_0403&PID_6001
%VID_0403&PID_6010.DeviceDesc%=FtdiPort2232.NTamd64,FTDIBUS%COMPORT&VID_0403&PID_6010
Add %VID_1234&PID_5678.DeviceDesc%=FtdiPort232.NTamd64,FTDIBUS%COMPORT&VID_1234&PID_5678
```

```
[Strings]
FTDI="FTDI"
DESC="CDM Driver Package"
DriversDisk="FTDI USB Drivers Disk"
PortsClassName = "Ports (COM & LPT)"
VID_0403&PID_6001.DeviceDesc="USB Serial Port"
VID_0403&PID_6010.DeviceDesc="USB Serial Port"
Add VID_1234&PID_5678.DeviceDesc="My New USB Device"
```

For details, refer to the information concerning changes to the FTDI driver related files.

☞ Note: The USB driver for the MU4-USB has the Circuit Design vendor ID, and you are not authorized to use it.

6.3 Directly Controlling the USB Chip

The USB/UART conversion chip uses the FTDI FT8U232BM, and by downloading the direct driver from the FTDI website, you can control the USB interface directly without using the COM port. However, we do not provide support for direct control. This should be carried out on the responsibility of the developer.

Important notice

- Customers are advised to consult with Circuit Design sales representatives before ordering. Circuit Design believes the provided information is accurate and reliable. However, Circuit Design reserves the right to make changes to this product without notice.
- Circuit Design products are neither designed nor intended for use in life support applications where malfunction can reasonably be expected to result in significant personal injury to the user. Any use of Circuit Design products in such safety-critical applications is understood to be fully at the risk of the customer and the customer must fully indemnify Circuit Design, Inc for any damages resulting from any improper use.
- As the radio module communicates using electronic radio waves, there are cases where transmission will be temporarily cut off due to the surrounding environment and method of usage. The manufacturer is exempt from all responsibility relating to resulting harm to personnel or equipment and other secondary damage.
- The manufacturer is exempt from all responsibility relating to secondary damage resulting from the operation, performance and reliability of equipment connected to the radio module.

Copyright

- All rights in this operation guide are owned by Circuit Design, Inc. No part of this document may be copied or distributed in part or in whole without the prior written consent of Circuit Design, Inc.

Cautions

- Do not use the equipment within the vicinity of devices that may malfunction as a result of electronic radio waves from the radio module.
- Communication performance will be affected by the surrounding environment, so communication tests should be carried out before actual use.
- Ensure that the power supply for the radio module is within the specified rating. Short circuits and reverse connections may result in overheating and damage and must be avoided at all costs.
- Ensure that the power supply has been switched off before attempting any wiring work.
- The case is connected to the GND terminal of the internal circuit, so do not make contact between the '+' side of the power supply terminal and the case.
- When batteries are used as the power source, avoid short circuits, recharging, dismantling, and pressure. Failure to observe this caution may result in the outbreak of fire, overheating and damage to the equipment. Remove the batteries when the equipment is not to be used for a long period of time. Failure to observe this caution may result in battery leaks and damage to the equipment.
- Do not use this equipment in vehicles with the windows closed, in locations where it is subject to direct sunlight, or in locations with extremely high humidity.
- The radio module is neither waterproof nor splash proof. Ensure that it is not splashed with soot or water. Do not use the equipment if water or other foreign matter has entered the case.
- Do not drop the radio module or otherwise subject it to strong shocks.
- Do not subject the equipment to condensation (including moving it from cold locations to locations with a significant increase in temperature.)
- Do not use the equipment in locations where it is likely to be affected by acid, alkalis, organic agents or corrosive gas.
- Do not bend or break the antenna. Metallic objects placed in the vicinity of the antenna will have a great effect on communication performance. As far as possible, ensure that the equipment is placed well away from metallic objects.
- The GND for the radio module will also affect communication performance. If possible, ensure that the case GND and the circuit GND are connected to a large GND pattern.

Warnings

- Do not take a part or modify the equipment.
- Do not remove the product label (the label attached to the upper surface of the module.) Using a module from which the label has been removed is prohibited.

Copyright 2020, Circuit Design, Inc.

REVISION HISTORY

Version	Date	Description	Remark
1.0	Sep. 2020	MU4-USBIF The first issue	