

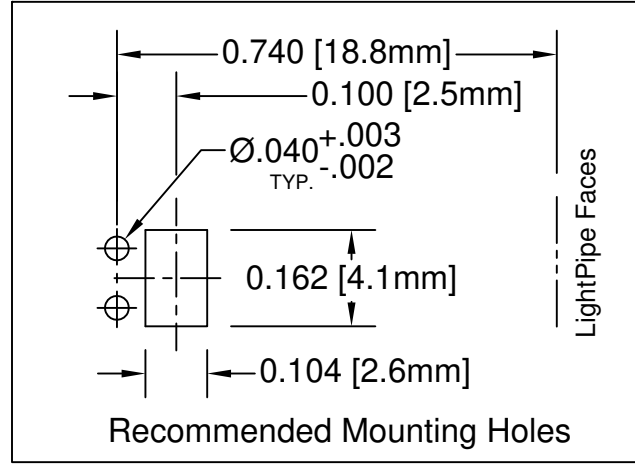

REV.	DESCRIPTION	DATE	APPROVED
E	Engineering Update w/o Changes	03/09/04	M. C.
F	Updated Material Note	02/05/16	J. C.

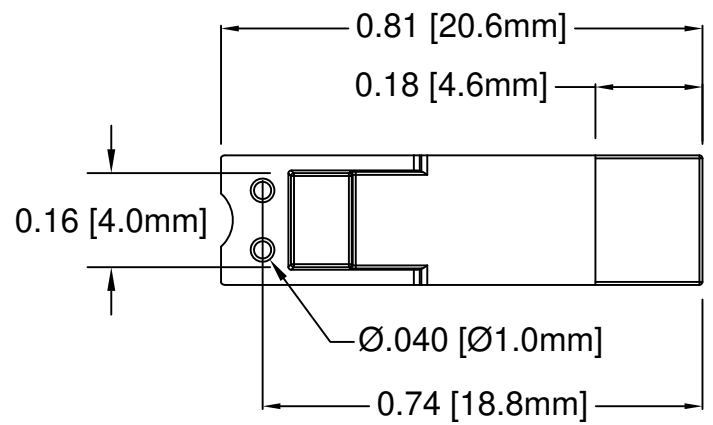
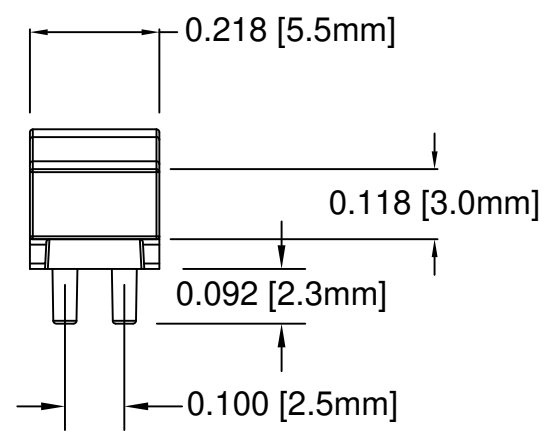
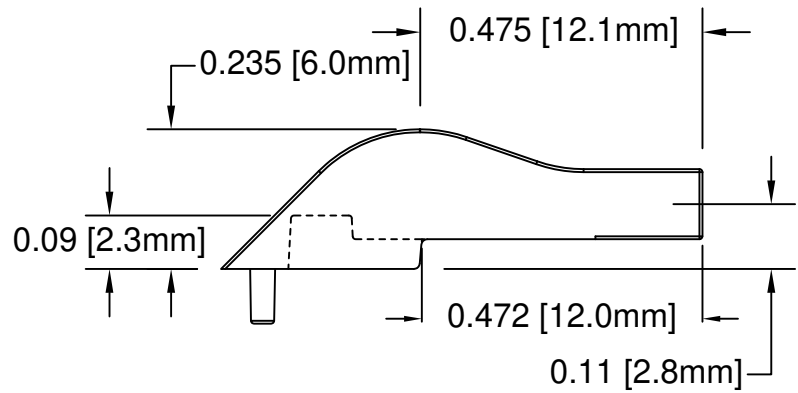
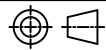

- 2. MATERIAL: POLYCARBONATE, 94V-0, CLEAR.
- 1. GENERAL SPECIFICATIONS: BIVAR MOLDED COMPONENT SPECIFICATION BV00-E101.

STANDARD TOLERANCE ( UNLESS OTHERWISE SPECIFIED )		 4 THOMAS, IRVINE, CA. 92618 TEL: (949) 951-8808 FAX: (949) 951-3974	
DECIMALS	ANGULAR		
.X ± .1	X° ± 1°		TITLE: LIGHT PIPE, 90° SURFACE MOUNT
.XX ± .01			PART NO: SLP-2
.XXX ± .005			REVISION: F
DESIGNED: Michael Chen	DATE: 09/11/03	CAGE CODE : 32559	SHEET # 1 OF 1
CHECKED: D. Green	DATE: 09/11/03	CAD GENERATED DOCUMENT. DO NOT MEASURE DRAWING.	