

NOTE:
MATERIAL
 HOUSING: PBT UL94V-0, BLACK
 CONTACT: BRASS
 NUT: BRASS
 SHELL: BRASS
 O-RING: NBR, BLACK
FINISH
 CONTACT: GOLD PLATED OVER 50 μ NICKEL
 NUT: NICKEL PLATED
 SHELL: NICKEL PLATED
ELECTRICAL
 RATED CURRENT: 1A
 RATED VOLTAGE: 60V
 INSULATION RESISTANCE: 100 M Ω hms MIN.
 CONTACT RESISTANCE: 10 m Ω hms MAX.
 WATER PROOF: IP67
ENVIRONMENT
 OPERATION TEMPERATURE: -40°C TO +85°C

852-002-113R00Y

1 = GOLD FLASH
 4 = 10 μ " GOLD

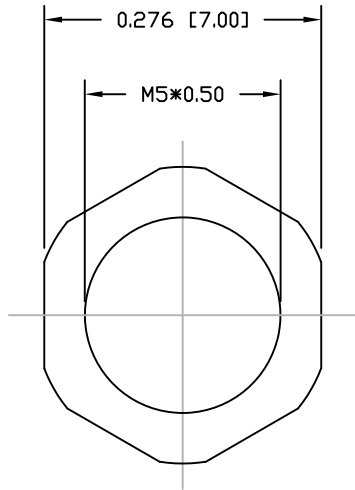

NUT

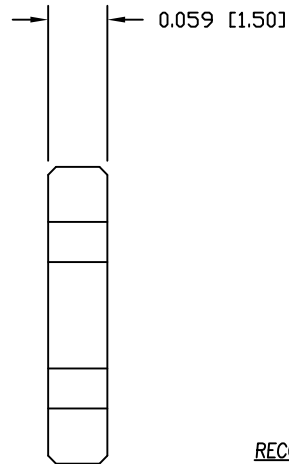

RECOMMEND PANEL CUT-OUT
 MAX. PANEL THICKNESS: 0.063" [1.60]

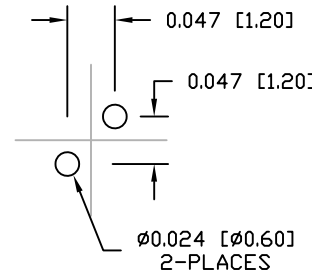

RECOMMENDED PCB LAYOUT

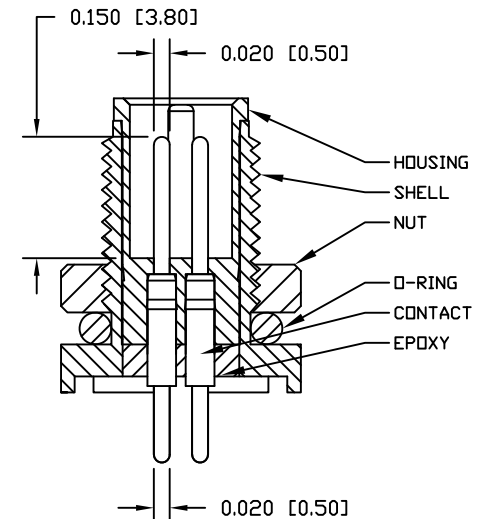

RoHS COMPLIANT

UNITS = inch [mm]

DO NOT SCALE FROM DRAWING



THESE DRAWINGS AND SPECIFICATIONS ARE THE PROPERTY OF NorComp AND SHALL NOT BE REPRODUCED, COPIED OR USED AS THE BASIS FOR THE MANUFACTURE OR SALE OF APPARATUS WITHOUT WRITTEN PERMISSION.

DRAWN:

M. SIGMON

DATE:

03-03-16

NorComp

SCALE: NTS

SHEET 1 OF 1

REV 7

DWG NO.

852-002-113R00Y