

TABLE 1						
STYLE	TAIL/OPTION	"A"	"B"	TERMINAL #1	TERMINAL #2	TERMINAL #3
-01	-RA	.103 [2.62]	.126 [3.20]	T-1S13-02-XX-2	T-1S13-03-XX-2	T-1S13-17-XX-2
-01	-FC	.139 [3.53]	.126 [3.20]	T-1S13-19-XX-2	T-1S13-22-XX-2	N/A
-01	RA W/END SHROUD	.139 [3.53]	.126 [3.20]	T-1S13-19-XX-2	T-1S13-22-XX-2	N/A
-01	*-FE	.287 [7.29]	.126 [3.20]	T-1S13-22-XX-2	T-1S13-28-XX-2	N/A
-04	-RA	.100 [2.54]	.075 [1.91]	T-1S13-20-XX-2	T-1S13-08-XX-2	N/A
-04	-FC	.150 [3.81]	.075 [1.91]	T-1S13-02-XX-2	T-1S13-03-XX-2	N/A
-04	RA W/END SHROUD	.150 [3.81]	.075 [1.91]	T-1S13-02-XX-2	T-1S13-03-XX-2	N/A
-05	-RA	.090 [2.29]	.065 [1.65]	T-1S13-07-XX-2	T-1S13-13-XX-2	N/A
-05	-FC	.160 [4.06]	.065 [1.65]	T-1S13-02-XX-2	T-1S13-03-XX-2	N/A
-05	RA W/END SHROUD	.160 [4.06]	.065 [1.65]	T-1S13-02-XX-2	T-1S13-03-XX-2	N/A

DIMENSIONS ARE IN INCHES		UNLESS OTHERWISE NOTED		TOLERANCES ARE:		TITLE:	DWG NO:
ONE PLACE DECIMALS ±.1[2.5]	THREE PLACE DECIMALS ±.005[.13]	ANGLES ±2°	TWO PLACE DECIMALS ±.01[.3]	FOUR PLACE DECIMALS ±.0020[.051]		2mm x 2mm RA TERMINAL STRIP ASSEMBLY	TMMH-1XX-XX-XX-X-XX-XX-XXX
							SHIT 1 OF 2

PLOT SCALE: 1 = .140/ DIMSCALE: 1 = .100

TMMH-1XX-XX-XX-X-XX-XX-XXX

No. OF POSITIONS
-02 THRU -50
(PER ROW)

LEAD STYLE
-01: .126 [3.20]
-04: .075 [1.91]
-05: .065 [1.65] MIN
(SEE TABLE 1)

POLARIZATION
SPECIFY POS -XXX TO BE OMITTED

SHROUD OPTION: (AVAILABLE ON -D ROW OPTION ONLY)
-ES: END SHROUDS (SEE FIG. 2- SHT 2, 9 POS MIN)
(NOT AVAILABLE WITH -FC TAIL OPTION)
-EP: GUIDE POST (SEE FIG. 4- SHT 2, 9 POS MIN)
(NOT AVAILABLE WITH -FC TAIL OPTION)
-EL: BOARD LOCK (SEE FIG. 3- SHT 2, 9 POS MIN)
(NOT AVAILABLE WITH -FC TAIL OPTION)

TAIL OPTION

-RA: RIGHT ANGLE
-FC: FLEX CARD (RIGHT ANGLE; -D ROW OPTION ONLY)
-FE: ELEVATED FLEX CARD (RIGHT ANGLE; -D ROW OPTION ONLY)

ROW OPTION

-D: DOUBLE (USE TMMH-XX-D-X)
-T: TRIPLE (USE TMMH-XX-T-X)
(AVAILABLE WITH -01 LEAD STYLE ONLY)

* = TAIL OPTION TO BE USED ON RIGHT ANGLE ONLY

PLATING SPECIFICATION

- L: LIGHT SELECTIVE GOLD (USE T-1S13-XX-L-2)
- F: FLASH GOLD (USE T-1S13-XX-F-2)
- S: SELECTIVE GOLD (USE T-1S13-XX-S-2)
- G: GOLD (USE T-1S13-XX-G-2)
- T: TIN (USE T-1S13-XX-T-2)
- H: HEAVY GOLD (USE T-1S13-XX-H-2)
- TM: MATTE TIN (USE T-1S13-XX-T-2)
- LM: LIGHT SELECTIVE GOLD/MATTE TIN TAIL (USE T-1S13-XX-L-2)
- FM: FLASH GOLD/MATTE TIN TAIL (USE T-1S13-XX-F-2)
- SM: SELECTIVE GOLD/MATTE TIN TAIL (USE T-1S13-XX-S-2)

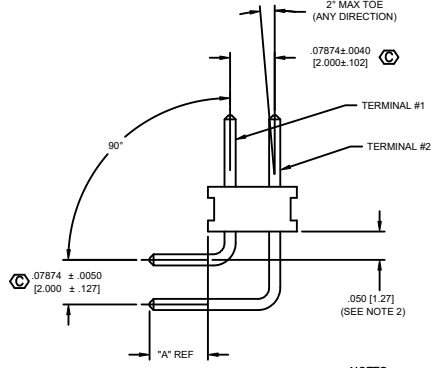
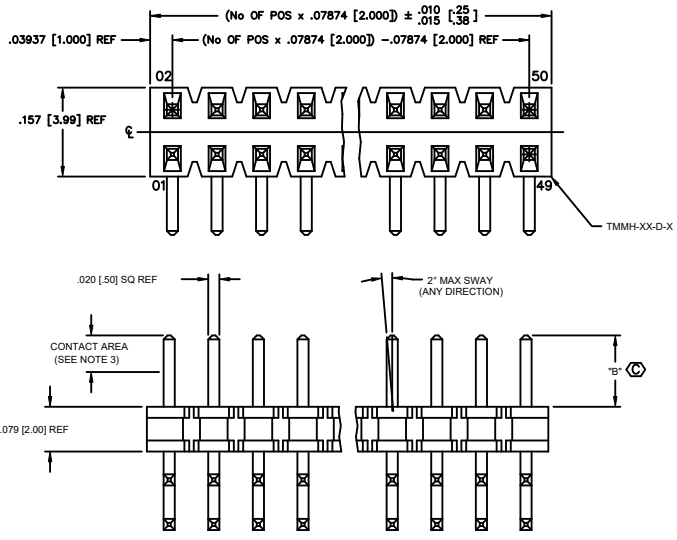

FIG 1

- NOTES:
1. PARTS MAY BE CUT TO POSITION.
 2. MEASURED AT BEND RADIUS; NOT AT END OF PIN.
 3. GOLD PLATING TO BE ON POST; TIN PLATING ON TAIL.
 4. Ⓞ REPRESENTS A CRITICAL DIMENSION.
 5. MINIMUM PUSHOUT FORCE: 1.0 LB.
 6. NOTE DELETED.
 7. MAX CUT FLASH TO BE .020.

PACKAGING VIEW

* ONLY TUBE POSITIONS -05 THROUGH -50

SCALE: .5x

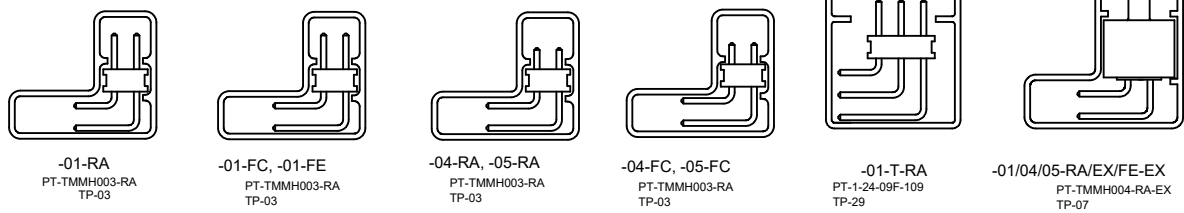

PROPRIETARY INFO
THIS DOCUMENT CONTAINS INFORMATION OF SAMTEC, INC. AND IS THE PROPERTY OF SAMTEC, INC. IT IS TO BE USED ONLY FOR THE PURPOSES SPECIFIED AND IS NOT TO BE REPRODUCED, COPIED, OR TRANSMITTED IN ANY FORM OR BY ANY MEANS, ELECTRONIC OR MECHANICAL, INCLUDING PHOTOCOPYING, RECORDING, OR BY ANY INFORMATION STORAGE AND RETRIEVAL SYSTEM, WITHOUT THE WRITTEN PERMISSION OF SAMTEC, INC.

samtec

520 PARK EAST BLVD. NEW ALBANY, INDIANA 47150
PHONE (812) 944-6733 P.O. BOX 1147
CODE 55322

MADE BY: PURVIS 12-17-96

TMMH-1XX-XX-XX-X-XX-XX-XXX
SHEET 1 OF 2