

1/4 HEX FEMALE STANDOFFS

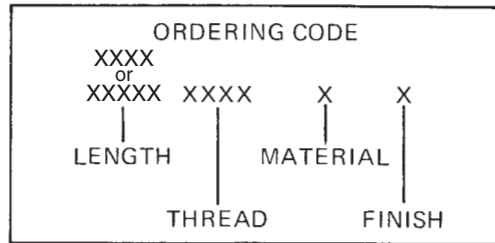
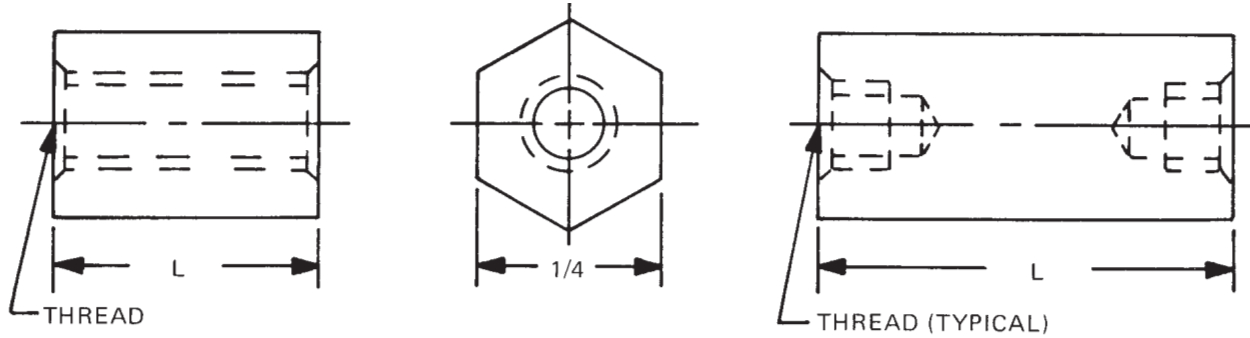

See page 10 for thread depth chart
 See page 9 for finish codes
 For non-standard parts contact Sales Office

LENGTH	PART NO.
3/32	2098A
1/8	2098
5/32	2098T
3/16	2099
7/32	2099T
1/4	2100
9/32	2100T
5/16	2101
11/32	2101T
3/8	2102
13/32	2102T
7/16	2103
15/32	2103T
1/2	2104
17/32	2104T
9/16	2105
19/32	2105T
5/8	2106
21/32	2106T
11/16	2107
23/32	2107T
3/4	2108
25/32	2108T
13/16	2109
27/32	2109T
7/8	2110
29/32	2110T

LENGTH	PART NO.
15/16	2111
31/32	2111T
1"	2112
1-1/16	2113
1-1/8	2114
1-3/16	2115
1-1/4	2116
1-5/16	2117
1-3/8	2118
1-7/16	2119
1-1/2	2120
1-9/16	2121
1-5/8	2122
1-11/16	2123
1-3/4	2124
1-13/16	2125
1-7/8	2126
1-15/16	2127
2"	2128
2-1/8	2129
2-1/4	2130
2-3/8	2131
2-1/2	2132
2-5/8	2133
2-3/4	2134
2-7/8	2135
3"	2136

LENGTH	PART NO.
3-1/4	2137
3-1/2	2138
3-3/4	2139
4"	2140
4-1/4	2141
4-1/2	2142
4-3/4	2143
5"	2144
5-1/4	2145
5-1/2	2146
5-3/4	2147
6"	2148
6-1/4	2149
6-1/2	2150
6-3/4	2151
7"	2152
7-1/4	2153
7-1/2	2154
7-3/4	2155
8"	2156
8-1/4	2157
8-1/2	2158
8-3/4	2159
9"	2160
9-1/4	2161
9-1/2	2162
9-3/4	2163
10"	2164

THREAD	CODE
4-40	440
6-32	632
8-32	832
10-32	1032

MATERIAL	CODE	RoHS
Aluminum	AL	YES
Brass	B	YES
Stainless Steel	SS	YES
Steel	S	YES
Nylon	N	YES