

APPROVED: \_\_\_\_\_  
 DATE: \_\_\_\_\_ TITLE: \_\_\_\_\_

Rev	AWO #	Description	Date	Appr
-		RELEASED	11/26/13	
A		UPDATE DRAWING	11/20/20	OW/RC

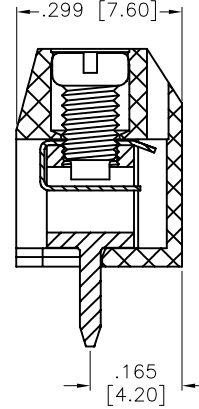
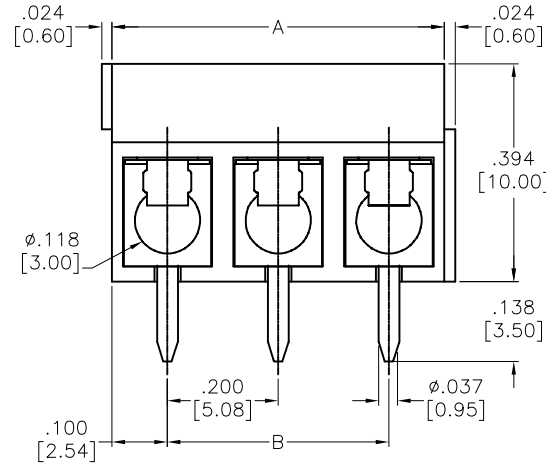
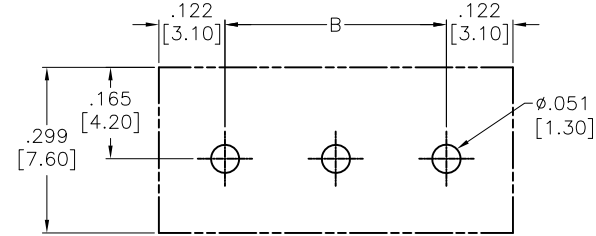
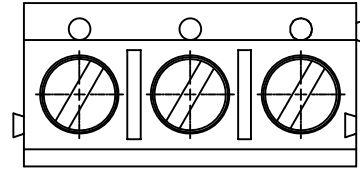

	Dim A	Dim B
2-6P	±.006 [0.15]	±.004 [0.10]
7-12P	±.008 [0.20]	±.008 [0.20]
13-18P	±.012 [0.30]	±.010 [0.25]
19-24P	±.016 [0.40]	±.012 [0.30]

**SPECIFICATIONS:**  
 Material:  
 Insulator: Thermoplastic, rated UL 94V-0  
 Insulator color: Blue  
 Wire guard: Stainless Steel  
 Contact: Brass, Tin plated  
 Screw: Steel, M2.6, Zinc plated  
 Electrical:  
 Voltage rating: 300 VAC  
 Current rating: 16 A  
 Withstanding Voltage: 1.6KV  
 Mechanical:  
 Solid wire(AWG): 14-22  
 Stranded wire(AWG): 14-22  
 Torque(Lb-In): 2.6  
 Wire strip length(mm): 5-6  
 Temperature Rating:  
 Operating temperature: -40°C to +115°C  
 Environmental:  
 Lead free, RoHS compliant.



Positions: 02 thru 24  
 A = .200 [5.08] x No. of Positions  
 B = .200 [5.08] x No. of Spaces

UNLESS OTHERWISE SPECIFIED  
 ALL DIMENSIONS ARE INCHES [MM]  
 TOLERANCES: EXCEPT AS NOTED

INCHES		HOLES	
.X	± .10	Ø.X	±.10
.XX	± .020	Ø.XX	±.015
.XXX	± .015	Ø.XXX	±.010



909 Rahway Avenue,  
 Union, NJ 07083  
 Phone: 908-687-5000  
 Fax: 908-687-5710

APPROVALS		DATE
DRAWN	AY	11/26/13
CHECKED	SL	11/26/13
APPROVED		

TITLE EURO BLOCK, .200 [5.08] PITCH			
SIZE X	PART NO. EBB-XX-D-BL	REV. A	
REF: S00007T	SCALE: NTS	SHEET 1 OF 1	