

ATLANTIC VERSION TERMINATOR INTERFACE ADAPTER	PART NUMBER	REVISION	DESCRIPTION	FEED TYPE	
	2266056-1	B	FINE CRIMP HEIGHT ADJUST	MECHANICAL ¹⁵	SUPERSEDED BY 5-2151323-1
	2266056-2	B	FINE CRIMP HEIGHT ADJUST	PNEUMATIC ¹⁵	SUPERSEDED BY 5-2151323-2
	2266056-5	B	FINE CRIMP HEIGHT ADJUST	SERVO LATCH PLATE ⁴	OBSOLETE
	2266056-6	B	NON CRIMP HEIGHT ADJUST	SERVO LATCH PLATE ⁴	OBSOLETE
	2266056-7	B	FINE CRIMP HEIGHT ADJUST	NONE	OBSOLETE
	7-2266056-7	A	CRIMP TOOLING KIT	-	

APPLICATOR DATA		
CRIMP	SIZE	TYPE
WIRE	2.03 mm [.080]	F
INSUL	6.35 mm [.250]	O

APPLICATOR INSTRUCTIONS 408-10389

TERMINAL DATA: TE TERMINAL		TE CRIMP SPECIFICATION	
TERMINAL NAME: DIA .4MM SOCKET CONTACT			
WIRE STRIP LENGTH		INSULATION DIAMETER RANGE	
4.55-5.31 mm [.179-.209 IN]		Ø 6.00 mm MAX [.236 IN MAX]	
TERMINAL APPLICATION SPECIFICATION	114-18118		
TERMINALS APPLIED ³			
TE TERMINAL	TE TERMINAL	TE SEAL	TE SEAL
962952-1	962952-2	963243-1	

WIRE SIZE	CRIMP HEIGHT mm [INCH]	CRIMP HEIGHT REFERENCE SETTING
1.00mm2	1.43+/-0.05 [.056+/- .002]	4.3
0.75mm2	1.34+/-0.05 [.053+/- .002]	5.0
0.50mm2	1.26+/-0.05 [.050+/- .002]	5.8

- ¹ RECOMMENDED SPARE PARTS
- ² GREASE BEARING SURFACES LIGHTLY
- 3. LUBRICATE DAILY PER THE APPLICATOR INSTRUCTION SHEET SUPPLIED WITH THE APPLICATOR.
- ⁴ APPLICATOR SPECIFIC DATA TO BE ENTERED INTO BLANK MEMORY CHIP AT ASSEMBLY. SEE BELOW FOR PART NUMBER:
MECHANICAL FEED WITH "SMART APPLICATOR" CONVERSION: 8-2266056-4
PNEUMATIC FEED WITH "SMART APPLICATOR" CONVERSION: 8-2266056-4
SERVO FEED WITH "FINE CRIMP HEIGHT ADJUST": 8-2266056-5
SERVO FEED WITH "NON-CRIMP HEIGHT ADJUST": 8-2266056-6
- 5. ADJUSTMENT OF THE STRIPPER MAY BE REQUIRED WHEN MOVING THE APPLICATOR BETWEEN BENCH AND LEADMAKER APPLICATIONS.
- ⁶ APPLY PART NUMBER 1-23419-5 LOCTITE TO THREADS OF ITEMS 62 & 180. APPLY PART NUMBER 2-23419-6 LOCTITE TO THREADS OF ITEM 242. FOR -6 ONLY APPLY PART NUMBER 1-23419-5 LOCTITE TO THREADS OF ITEM 37.
- ⁷ GREASE THREADS, GROOVE AND O-RING ON ITEMS 35 & 252.
- ⁸ MAGNET, ITEM 166 MUST BE ORIENTED CORRECTLY IN ORDER TO PROPERLY ACTUATE THE COUNTER.
- ⁹ CRIMP HEIGHT REFERENCE SETTING WAS THE SETTING USED WHEN THE APPLICATOR WAS QUALIFIED AT THE FACTORY. ADJUSTMENT MAY BE NECESSARY WHEN RUNNING APPLICATOR IN THE FIELD.
- ¹⁰ SPARE FEED CAM STORAGE LOCATION REFER TO INSTRUCTION SHEET FOR ADDITIONAL INFORMATION.
- ¹¹ TO CONVERT THE APPLICATOR TO A NON-CARRIER CUTTING STYLE, REMOVE ITEM 13 AND ATTACH TO THE LOCATION ON THE BACK SIDE OF THE HOUSING. REFER TO INSTRUCTION SHEET FOR ADDITIONAL INFORMATION.
- ¹² WHEN ASSEMBLING -6 NON-CRIMP HEIGHT ADJUST APPLICATOR USE SHIM PACK 2119957-2 TO ALIGN APPLICATOR'S MAXIMUM WIRE CRIMP HEIGHT AT NORMAL TERMINATOR SHUT HEIGHT
- ¹³ THIS APPLICATOR APPLIES TERMINAL WITH A SEAL. INSULATION RANGE QUOTED IS THAT OF THE TERMINAL. THE SEAL INSULATION RANGE IS Ø1.40-2.00mm.
- ¹⁴ APPLY TORO-SEAL IN ALLEN SOCKET TO FILL HOLE AFTER FLAT HD HAS BEEN ADJUSTED TO CORRECT HEIGHT AT QUALIFICATION. APPLY #1-23419-5 LOC-TITE TO THREADS.
- ¹⁵ MUST BE FED OFF OF SLOT ON CARRIER STRIP
- ¹⁶ THIS APPLICATOR IS SPECIFIC FOR USE IN A STRIPPER SEAL TERMINATING UNIT.

***WARNING**
ON INSTALLATION, SET WIRE DISC, ITEM 40 TO LARGEST WIRE SIZE SETTING. USE OF SETTINGS BELOW MINIMUM REQUIRED CRIMP HEIGHT SETTING WILL CAUSE DAMAGE TO CRIMP TOOLING.

	-77	-7	-6	-5	-2	-1	PART NO	DESCRIPTION	ITEM NO
¹²	-	-	1	-	-	-	2119957-2	APPLICATOR SHIM PACK	260

ATLANTIC VERSION
Shown on sheets 1 of 4 & 2 of 4
(Pacific version shown on sheets 3 of 4 & 4 of 4)

SET UP GAUGE		LOC	DIST	REVISIONS					
2119599-1		A	66	P	LTN	DESCRIPTION	DATE	OWN	APVD
				1		DEVELOPMENT	24SEP2013	KH	UG
				A		RELEASED	18OCT2013	BH	GB
				B		ECR-17-003780	15MAR2017	TB	CT
				B1		ECR-20-013853	28SEP2020	TB	RK

⁷	-	1	-	1	1	1	8-21084-0	O-RING, .676 ID, .070 DIA. MAT.	252
	-	-	-	-	1	-	2119640-1	PUSH ROD, AIR FEED	250
	-	-	-	-	1	-	1803259-1	BUSHING, FLANGED	249
	-	-	-	-	1	-	2119641-1	FEED CAM, AIR FEED	248
	-	1	-	1	1	1	2119798-1	DETENT PIN	247
	-	1	-	1	1	1	1-22279-3	SPRING, COMPRESSION	246
	-	-	1	-	-	-	2119758-1	RAM, AMP STYLE, SIDE FEED, NON-ADJ.	245
	-	1	1	1	1	1	2119082-1	CAM, SNAIL, INSULATION ADJUSTMENT	244
	-	1	1	1	1	1	2079764-1	WASHER, WAVE SPRING, CREST-TO-CREST	243
⁶	-	1	1	1	1	1	2119083-1	RETAINER, INSULATION DIAL	242
	-	1	1	1	1	1	7-18023-7	SCR, SKT HD CAP M3 X 4.0	241
	-	-	2	2	-	-	2168400-6	SHCS, LOW HEAD, RoHS, M5 X 16	240
	-	-	-	-	-	1	2119580-1	MECHANICAL FEED ASSEMBLY	239
	-	-	-	-	-	1	2063440-1	AIR FEED MODULE	238
	-	-	1	1	-	-	2119740-2	TAG, IDENTIFICATION	213
	-	-	1	1	-	-	1901094-3	SPACER, FEEDER	198
	-	1	1	1	1	1	4-1722335-3	STRIPPER, SIDE FEED	182
	-	1	1	1	1	1	1-5018030-0	NUT, HEX, REG, RoHS, M3.5	181
⁶	-	1	1	1	1	1	1-1752354-9	STANDOFF, HOLD-DOWN	180
	-	1	1	1	1	1	993111-1	PIN, SLOTTED SPRING 3.0 X 20.0	177
	-	1	1	1	1	1	5-22280-0	SPRING, COMPRESSION	176
	-	1	1	1	1	1	1752353-3	GUIDE PIN, HOLDDOWN	175
	-	1	1	1	1	1	1901680-2	GUIDE PIN, HOLDDOWN	174
	-	-	-	-	2	-	21045-3	RING, RETAIN, EXTERN, 3/16 CRESCENT	172
	-	1	1	1	1	1	994969-1	MAGNET, RARE EARTH HIGH ENERGY	166
	-	REF	REF	REF	REF	REF	994970-2	COUNTER, MAGNETIC	164
	-	-	-	-	1	-	240638-1	SPRING, FEED FINGER	163
	-	-	-	-	1	-	3-23627-7	PIN, RETAIN, GRVD, 3/16 X .854	137
	-	-	-	-	1	-	2119799-1	HOLDER, FEED FINGER, AF	136
	-	-	REF	REF	-	-	SEE NOTE 4	MEMORY CHIP, PROGRAMMED	135
	-	-	1	1	-	-	1633743-1	SERVO FEED LATCH ASM	133
	-	1	1	1	1	1	1-18028-2	WASHER, FLAT, REG M4	119
	-	-	REF	REF	-	-	2119944-1	FEED FINGER ASSEMBLY, SF	117
	-	1	1	1	1	1	455888-6	SPACER, CRIMPER	82
	-	1	1	1	1	1	2119956-1	DOCUMENTATION PACKAGE	71
	-	1	1	1	1	1	1-2119791-0	DEPRESSOR, WIRE	70
	-	1	-	-	1	1	2119740-1	TAG, IDENTIFICATION	67
	-	2	2	2	2	2	2168078-1	SCREW, DRIVE, RH, RoHS, 2 x .188	66
	-	1	-	1	1	1	2119793-1	LIMITER, ADJUSTMENT BOLT	63
⁶	-	3	-	3	3	3	992763-5	SCR, SET, SOC, CONE PNT, M3 x 4.0	62
	-	1	1	1	1	1	2079383-4	SCR, BHSC, RoHS (M4 X 8)	60
	-	-	-	-	1	1	5-18022-5	SCR, HEX HD CAP, M4 X 6.0	59
	-	1	1	1	1	1	985575-3	SCR, FLT SKT HD CAP M3 X 10.0	57
	-	-	-	-	1	1	1338685-1	PAWL, FEED	56
	-	4	4	4	4	4	2168400-1	SHCS, LOW HEAD, RoHS, M4 X 12	54
	-	-	-	-	1	2	18023-9	SCR, SKT HD CAP M4 X 6.0	49
	-	-	-	-	-	1	2119652-1	FEED CAM, PRE FEED	48
	-	-	-	-	-	1	2119653-1	FEED CAM, POST FEED	47
	-	1	1	1	1	1	2-2119656-1	APPLICATOR BASIC ASSEMBLY, SF	46
	-	1	-	1	1	1	2119370-1	RAM, AMP STYLE, SIDE FEED	44
	-	1	1	1	1	1	2079383-7	SCR, BHSC, RoHS (M8 X 25)	41
	-	1	-	1	1	1	2119645-1	DISC, NUMBERED FA WIRE ADJUSTMENT	40
	-	1	-	1	1	1	2119957-1	APPLICATOR SHIM PACK	39
	-	1	1	1	1	1	2119644-1	RAM WASHER, PRECISION	38
⁶	-	1	1	1	1	1	2119085-1	FA HEAD, ATLANTIC STYLE	37
⁷	-	1	-	1	1	1	2119092-1	BOLT, ADJUSTMENT	35
	-	1	1	1	1	1	1-1752356-7	SUPPORT, TERMINAL	34
	-	2	2	2	2	2	2079383-5	SCR, BHSC, RoHS (M4 X 20)	33
	-	1	1	1	1	1	2161328-1	HEX HEAD, FLANGED, M5 x 8mm LONG	32
	-	1	1	1	1	1	1320908-7	SPACER, STRIP GUIDE	30
	-	1	1	1	1	1	2119959-2	ASSEMBLY, STRIP GUIDE	29
	-	1	1	1	1	1	455888-3	SPACER, CRIMPER	28
	-	1	1	1	1	1	1320928-2	STRIP GUIDE	24
¹	-	1	1	1	1	1	2119806-1	INSERT, SHEAR	13
	-	1	1	1	1	1	3-22280-3	SPRING, COMPRESSION	12
	-	1	1	1	1	1	1-356885-4	STOP, SHEAR	11
¹	-	1	1	1	1	1	2119805-1	SHEAR HOLDER, FRONT	10
¹	-	1	1	1	1	1	318707-1	FLOATING SHEAR, FRONT	9
¹	1	1	1	1	1	1	9-1333204-4	ANVIL, COMBINATION	8
	-	1	1	1	1	1	2119781-5	DEPRESSOR, SHEAR	5
	-	1	1	1	1	1	238011-1	BLOCK, CRIMPER SPACER	4
¹	1	1	1	1	1	1	2-1803019-2	CRIMPER, INSULATION O	3
¹	1	1	1	1	1	1	2-456405-8	CRIMPER, WIRE PREMIUM	1

DIMENSIONS:		TOLERANCES UNLESS OTHERWISE SPECIFIED:		MATERIAL:		FINISH:		WEIGHT:		SCALE:	
mm	0 PLC ±	1 PLC ±	2 PLC ±	3 PLC ±	4 PLC ±	ANGLES	FINISH			Customer Accessible Production Drawing	SCALE 1:2
APPLICATOR SPEC		APPLICATOR SPEC		APPLICATOR SPEC		APPLICATOR SPEC		APPLICATOR SPEC		APPLICATOR SPEC	
SIZE		CAGE CODE		DRAWING NO		RESTRICTED TO		WEIGHT		SCALE	
A1		00779		C=2266056				SHEET 1 OF 4		REV B1	

LOC		DIST		REVISIONS			
A	66	P	LTN	DESCRIPTION	DATE	DWN	APVD
		-		SEE SHEET 1			

FEED TYPE MECHANICAL

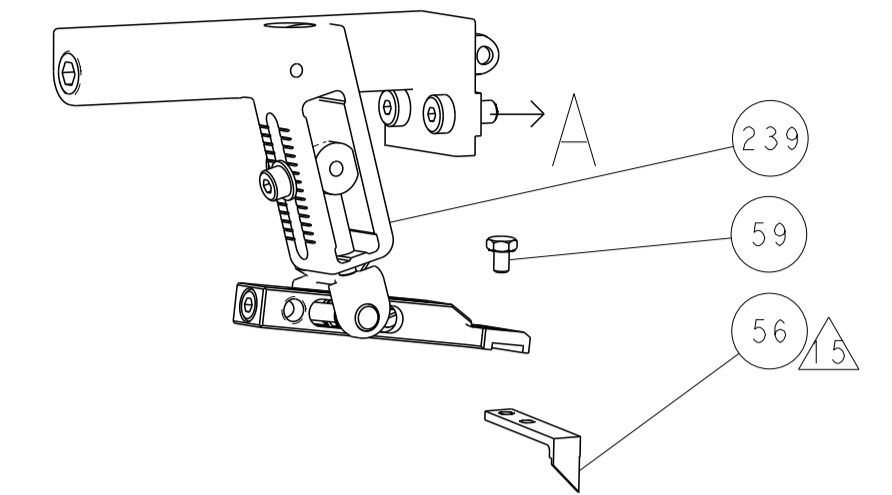

PNEUMATIC

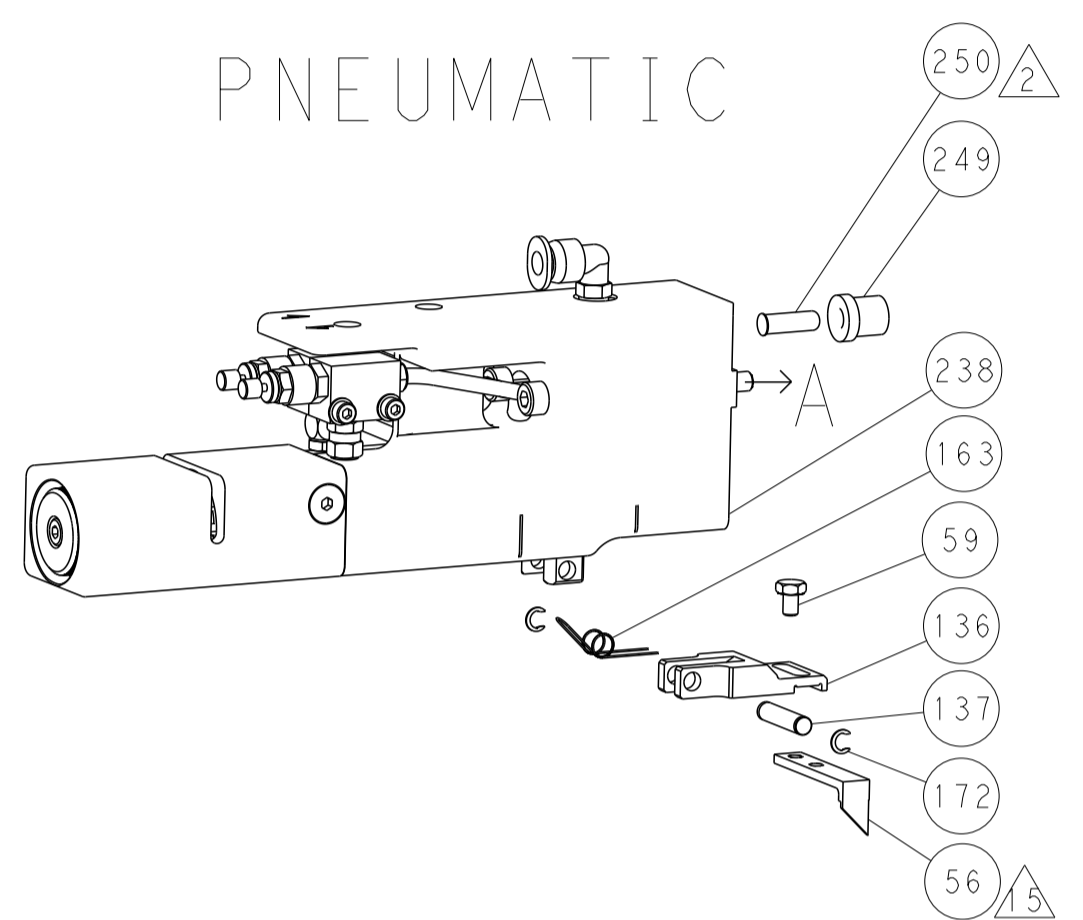

SERVO LATCH PLATE

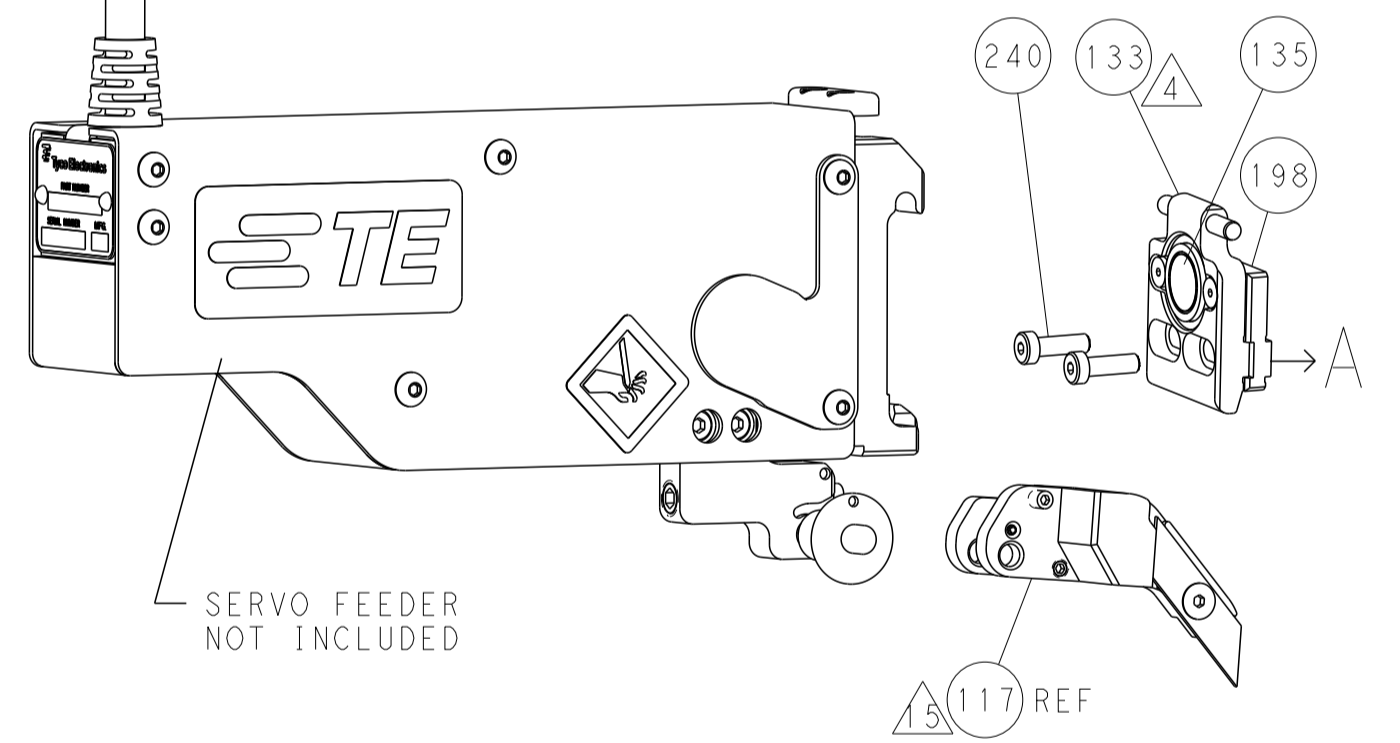

CAM POSITIONS

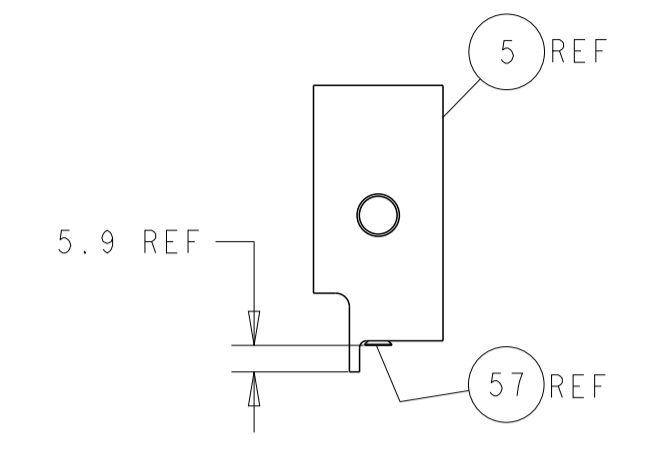
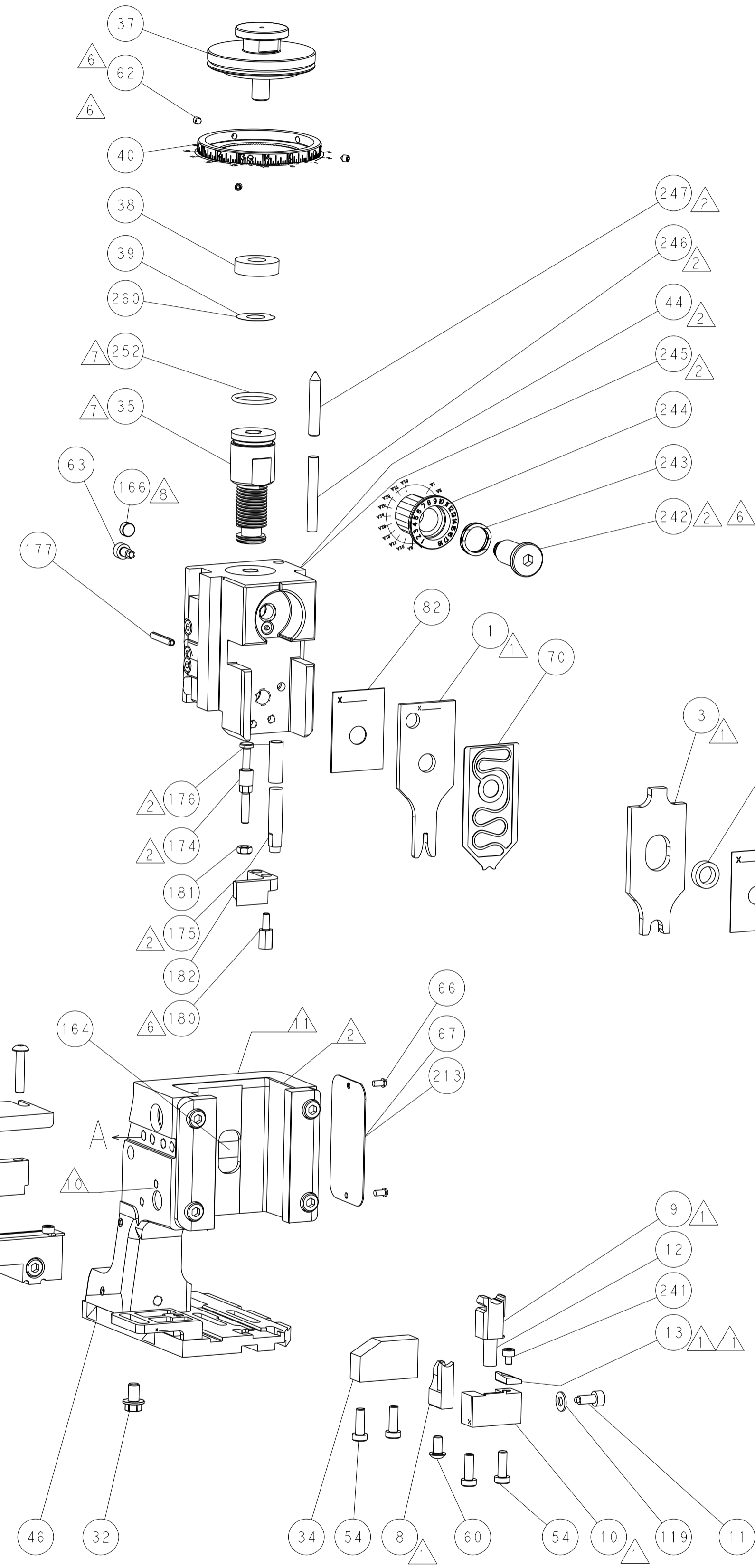
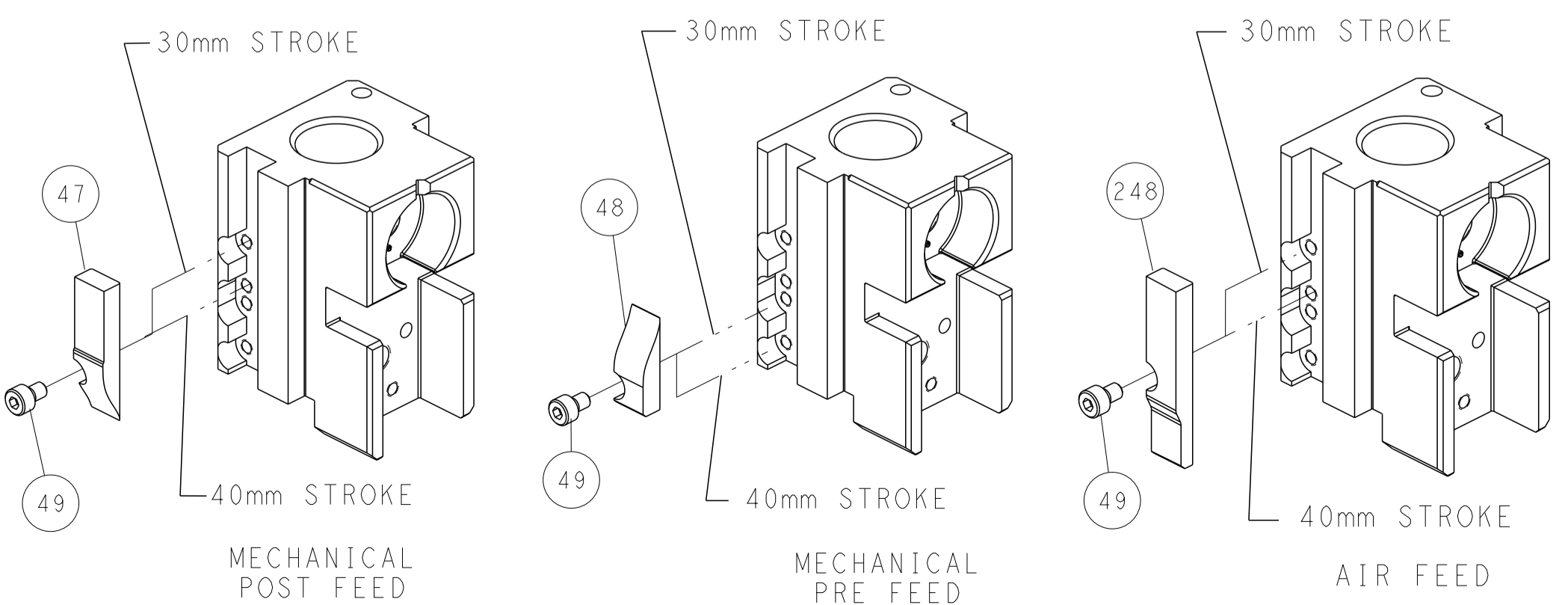

SHEAR DEPRESSOR DETAIL

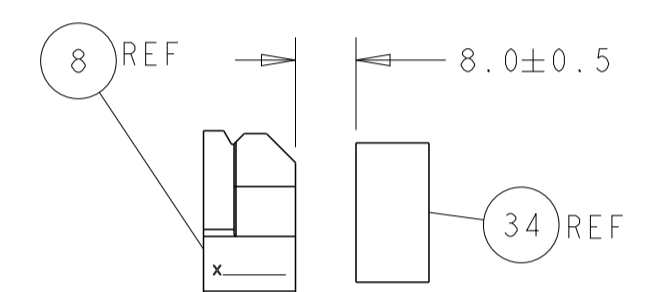

TERMINAL SUPPORT LOCATION

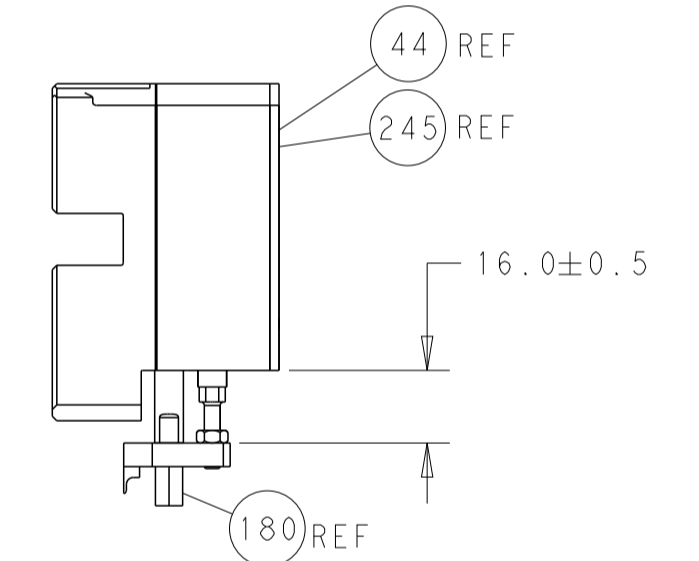

HOLDDOWN SET-UP

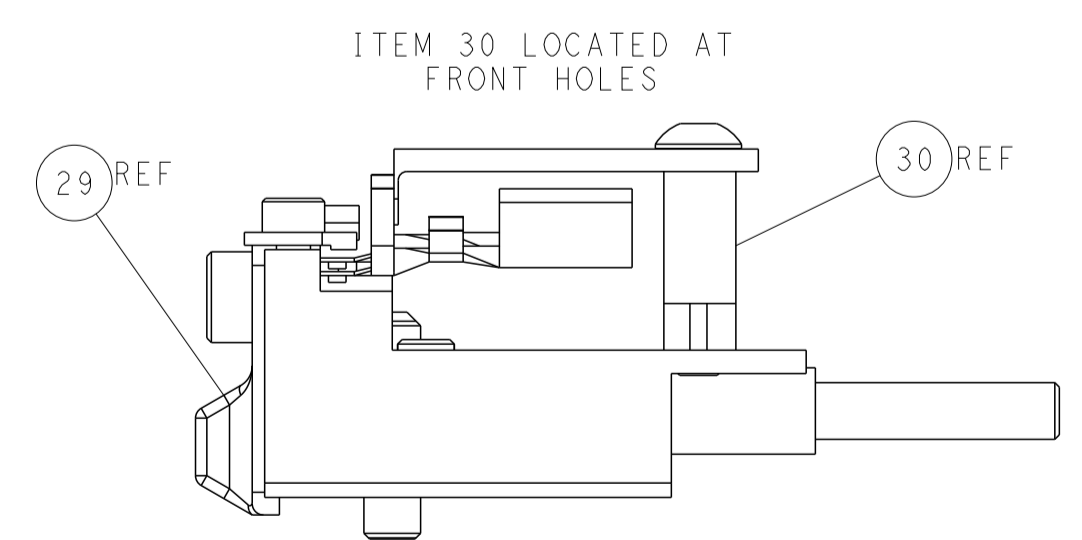

FEED TRACK POSITION GUIDE BY INSULATION BARREL

ATLANTIC VERSION
 Shown on sheets 1 of 4 & 2 of 4
 (Pacific version shown on sheets 3 of 4 & 4 of 4)

DIMENSIONS: mm 		TOLERANCES UNLESS OTHERWISE SPECIFIED: 0 PLC ± 1 PLC ± 2 PLC ± 3 PLC ± 4 PLC ± ANGLES ± FINISH		DWN R. HUANG 24SEP2013 CHK L. ZHANG 24SEP2013 APVD J. GUO 24SEP2013 NAME Ocean Side Feed Applicator SIZE CAGE CODE DRAWING NO. RESTRICTED TO A1 00779 C=2266056 Customer Accessible Production Drawing SCALE 1:2 SHEET 2 OF 4 REV B1	
MATERIAL:				WEIGHT:	

PACIFIC VERSION TERMINATOR INTERFACE ADAPTER	PART NUMBER	REVISION	DESCRIPTION	FEED TYPE	
	2-2266056-1	B	FINE CRIMP HEIGHT ADJUST	MECHANICAL	OBSOLETE
	2-2266056-2	B	FINE CRIMP HEIGHT ADJUST	PNEUMATIC	OBSOLETE
	2-2266056-5	B	FINE CRIMP HEIGHT ADJUST	SERVO LATCH PLATE	OBSOLETE
	2-2266056-7	B	FINE CRIMP HEIGHT ADJUST	NONE	OBSOLETE
	7-2266056-7	A	CRIMP TOOLING KIT	-	

APPLICATOR DATA		
CRIMP WIRE	SIZE	TYPE
INSUL	6.35 mm [.250]	0
APPLICATOR INSTRUCTIONS 408-10389		

TERMINAL DATA: TE TERMINAL		TE CRIMP SPECIFICATION	
TERMINAL NAME: DIA .4MM SOCKET CONTACT			
WIRE STRIP LENGTH		INSULATION DIAMETER RANGE	
4.55-5.31 mm [.179-.209 IN]		Ø 6.00 mm MAX [.236 IN MAX]	
TERMINAL APPLICATION SPECIFICATION	114-18118		
TERMINALS APPLIED			
TE TERMINAL	TE TERMINAL	TE SEAL	TE SEAL
962952-1	962952-2	963243-1	

WIRE SIZE	CRIMP HEIGHT mm [INCH]	CRIMP HEIGHT REFERENCE SETTING
1.00mm2	1.43 +/- 0.05 [.056 +/- .002]	4.3
0.75mm2	1.34 +/- 0.05 [.053 +/- .002]	5.0
0.50mm2	1.26 +/- 0.05 [.050 +/- .002]	5.8

- RECOMMENDED SPARE PARTS
- GREASE BEARING SURFACES LIGHTLY
- 3. LUBRICATE DAILY PER THE APPLICATOR INSTRUCTION SHEET SUPPLIED WITH THE APPLICATOR.
- APPLICATOR SPECIFIC DATA TO BE ENTERED INTO BLANK MEMORY CHIP AT ASSEMBLY. SEE BELOW FOR PART NUMBER:
 MECHANICAL FEED WITH "SMART APPLICATOR" CONVERSION: 8-2266056-4
 PNEUMATIC FEED WITH "SMART APPLICATOR" CONVERSION: 8-2266056-4
 SERVO FEED WITH "FINE CRIMP HEIGHT ADJUST": 8-2266056-5
- 5. ADJUSTMENT OF THE STRIPPER MAY BE REQUIRED WHEN MOVING THE APPLICATOR BETWEEN BENCH AND LEADMAKER APPLICATIONS.
- APPLY PART NUMBER 1-23419-5 LOCTITE TO THREADS OF ITEMS 62 & 180. APPLY PART NUMBER 2-23419-6 LOCTITE TO THREADS OF ITEM 242.
- GREASE THREADS, GROOVE AND O-RING ON ITEMS 139 & 152.
- MAGNET MUST BE ORIENTED CORRECTLY IN ORDER TO PROPERLY ACTUATE THE COUNTER.
- CRIMP HEIGHT REFERENCE SETTING WAS THE SETTING USED WHEN THE APPLICATOR WAS QUALIFIED AT THE FACTORY. ADJUSTMENT MAY BE NECESSARY WHEN RUNNING APPLICATOR IN THE FIELD.
- SPARE FEED CAM STORAGE LOCATION REFER TO INSTRUCTION SHEET FOR ADDITIONAL INFORMATION.
- TO CONVERT THE APPLICATOR TO A NON-CARRIER CUTTING STYLE, REMOVE ITEM 13 AND ATTACH TO THE LOCATION ON BACK SIDE OF THE HOUSING. REFER TO INSTRUCTION SHEET FOR ADDITIONAL INFORMATION.
- THIS APPLICATOR APPLIES TERMINAL WITH A SEAL. INSULATION RANGE QUOTED IS THAT OF THE TERMINAL. THE SEAL INSULATION RANGE IS Ø1.40-2.00mm.
- APPLY TORO-SEAL IN ALLEN SOCKET TO FILL HOLE AFTER FLAT HD HAS BEEN ADJUSTED TO CORRECT HEIGHT AT QUALIFICATION. APPLY #1-23419-5 LOC-TITE TO THREADS.
- MUST BE FED OFF OF SLOT ON CARRIER STRIP
- THIS APPLICATOR IS SPECIFIC FOR USE IN A STRIPPER SEAL TERMINATING UNIT.

***WARNING**
 ON INSTALLATION, SET WIRE DISC, ITEM 40 TO LARGEST WIRE SIZE SETTING. USE OF SETTINGS BELOW MINIMUM REQUIRED CRIMP HEIGHT SETTING WILL CAUSE DAMAGE TO CRIMP TOOLING.

PACIFIC VERSION
 Shown on sheets 3 of 4 & 4 of 4
 (Atlantic version shown on sheets 1 of 4 & 2 of 4)

SET UP GAUGE	LOC	DIST	REVISIONS			
2119599-1	A	66	REV	DATE	BY	APPD
			-	SEE SHEET 1		

REV	DATE	BY	APPD	DESCRIPTION	ITEM NO	
-	1	1	1	2119782-1	FINE ADJUST HEAD ASM, PACIFIC STYLE	251
-	-	-	1	2119640-1	PUSH ROD, AIR FEED	250
-	-	-	1	1803259-1	BUSHING, FLANGED	249
-	1	1	1	1-22279-3	SPRING, COMPRESSION	246
-	1	1	1	2119082-1	CAM, SNAIL, INSULATION ADJUSTMENT	244
-	1	1	1	2079764-1	WASHER, WAVE SPRING, CREST-TO-CREST	243
	1	1	1	2119083-1	RETAINER, INSULATION DIAL	242
-	1	1	1	7-18023-7	SCR, SKT HD CAP M3 X 4.0	241
-	-	2	-	2168400-6	SHCS, LOW HEAD, RoHS, M5 X 16	240
-	-	-	1	2119580-1	MECHANICAL FEED ASSEMBLY	239
-	-	-	1	2063440-1	AIR FEED MODULE	238
-	-	1	-	2119740-2	TAG, IDENTIFICATION	213
-	-	1	-	1901094-3	SPACER, FEEDER	198
-	1	1	1	4-1722335-3	STRIPPER, SIDE FEED	182
-	1	1	1	1-5018030-0	NUT, HEX, REG, RoHS, M3.5	181
	1	1	1	1-1752354-9	STANDOFF, HOLD-DOWN	180
-	1	1	1	9931111-1	PIN, SLOTTED SPRING 3.0 X 20.0	177
-	1	1	1	5-22280-0	SPRING, COMPRESSION	176
-	1	1	1	1752353-3	GUIDE PIN, HOLDDOWN	175
-	1	1	1	1901680-2	GUIDE PIN, HOLDDOWN	174
-	-	-	2	21045-3	RING, RETAIN, EXTERN, 3/16 CRESCENT	172
-	1	1	1	994969-1	MAGNET, RARE EARTH HIGH ENERGY	166
-	REF	REF	REF	994970-2	COUNTER, MAGNETIC	164
-	-	-	1	240638-1	SPRING, FEED FINGER	163
	1	1	1	8-21084-1	O-RING, .801 ID, .070 DIA. MAT.	152
-	-	-	1	2119641-2	FEED CAM, AIR FEED	151
-	1	1	1	2119798-2	DETENT PIN	145
-	1	1	1	2079383-8	SCR, BHSC, RoHS (M4 X 16)	144
-	4	4	4	2168400-5	SHCS, LOW HEAD, RoHS, M4 X 20	143
-	-	-	1	2119653-2	FEED CAM, POST FEED	142
-	1	1	1	2-2119656-2	APPLICATOR BASIC ASSEMBLY, SF	141
	1	1	1	2119650-1	RAM, ASIAN STYLE, SIDE FEED	140
-	1	1	1	2119092-2	BOLT, ADJUSTMENT	139
-	-	-	1	3-23627-7	PIN, RETAIN, GRVD, 3/16 X .854	137
-	-	-	1	2119799-1	HOLDER, FEED FINGER, AF	136
-	-	REF	-	SEE NOTE 4	MEMORY CHIP, PROGRAMMED	135
-	-	1	-	1633743-1	SERVO FEED LATCH ASM	133
-	1	1	1	1-18028-2	WASHER, FLAT, REG M4	119
-	-	REF	-	2119944-1	FEED FINGER ASSEMBLY, SF	117
-	1	1	1	455888-6	SPACER, CRIMPER	82
-	1	1	1	2119956-1	DOCUMENTATION PACKAGE	71
-	1	1	1	1-2119791-0	DEPRESSOR, WIRE	70
-	1	-	1	2119740-1	TAG, IDENTIFICATION	67
-	2	2	2	2168078-1	SCREW, DRIVE, RH, RoHS, 2 x .188	66
	1	1	1	2119793-1	LIMITER, ADJUSTMENT BOLT	63
-	3	3	3	992763-5	SCR, SET, SOC, CONE PNT, M3 X 4.0	62
-	-	-	1	5-18022-5	SCR, HEX HD CAP, M4 X 6.0	59
-	1	1	1	985575-3	SCR, FLT SKT HD CAP M3 X 10.0	57
-	-	-	1	1338685-1	PAWL, FEED	56
-	-	-	1	18023-9	SCR, SKT HD CAP M4 X 6.0	49
-	-	-	1	2119652-1	FEED CAM, PRE FEED	48
-	1	1	1	2079383-7	SCR, BHSC, RoHS (M8 X 25)	41
-	1	1	1	2119645-1	DISC, NUMBERED FA WIRE ADJUSTMENT	40
-	1	1	1	2119957-1	APPLICATOR SHIM PACK	39
-	1	1	1	2119644-1	RAM WASHER, PRECISION	38
-	1	1	1	1-1752356-7	SUPPORT, TERMINAL	34
-	2	2	2	2079383-5	SCR, BHSC, RoHS (M4 X 20)	33
-	1	1	1	2161328-1	HEX HEAD, FLANGED, M5 X 8mm LONG	32
-	1	1	1	1320908-7	SPACER, STRIP GUIDE	30
-	1	1	1	2119959-2	ASSEMBLY, STRIP GUIDE	29
-	1	1	1	455888-3	SPACER, CRIMPER	28
	1	1	1	1320928-2	STRIP GUIDE	24
	1	1	1	2119806-1	INSERT, SHEAR	13
-	1	1	1	3-22280-3	SPRING, COMPRESSION	12
-	1	1	1	1-356885-4	STOP, SHEAR	11
	1	1	1	2119805-1	SHEAR HOLDER, FRONT	10
	1	1	1	318707-1	FLOATING SHEAR, FRONT	9
	1	1	1	9-1333204-4	ANVIL, COMBINATION	8
-	1	1	1	2119781-5	DEPRESSOR, SHEAR	5
-	1	1	1	238011-1	BLOCK, CRIMPER SPACER	4
	1	1	1	2-1803019-2	CRIMPER, INSULATION O	3
	1	1	1	2-456405-8	CRIMPER, WIRE PREMIUM	1

DIMENSIONS:		TOLERANCES UNLESS OTHERWISE SPECIFIED:		MATERIAL:	
mm	0 PLC ±	1 PLC ±	2 PLC ±	3 PLC ±	4 PLC ±
	ANGLES ±	FINISH ±			
OWN: H. HUANG 24SEP2013		CHK: L. ZHANG 24SEP2013		NAME: Ocean Side Feed Applicator	
APVD: H. GUO 24SEP2013		PRODUCT SPEC		SIZE: A1 00779	
APPLICATION SPEC		WEIGHT		SCALE: 1:2	
Customer Accessible Production Drawing		SHEET 3 OF 4		REV: B1	

LOC		DIST		REVISIONS			
A	66	P	LTM	DESCRIPTION	DATE	OWN	APVD
-	-	-	-	SEE SHEET 1	-	-	-

FEED TYPE MECHANICAL

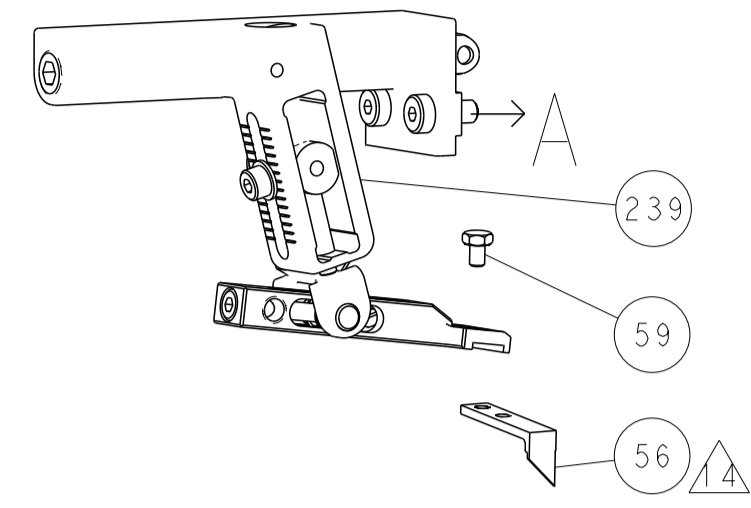

PNEUMATIC

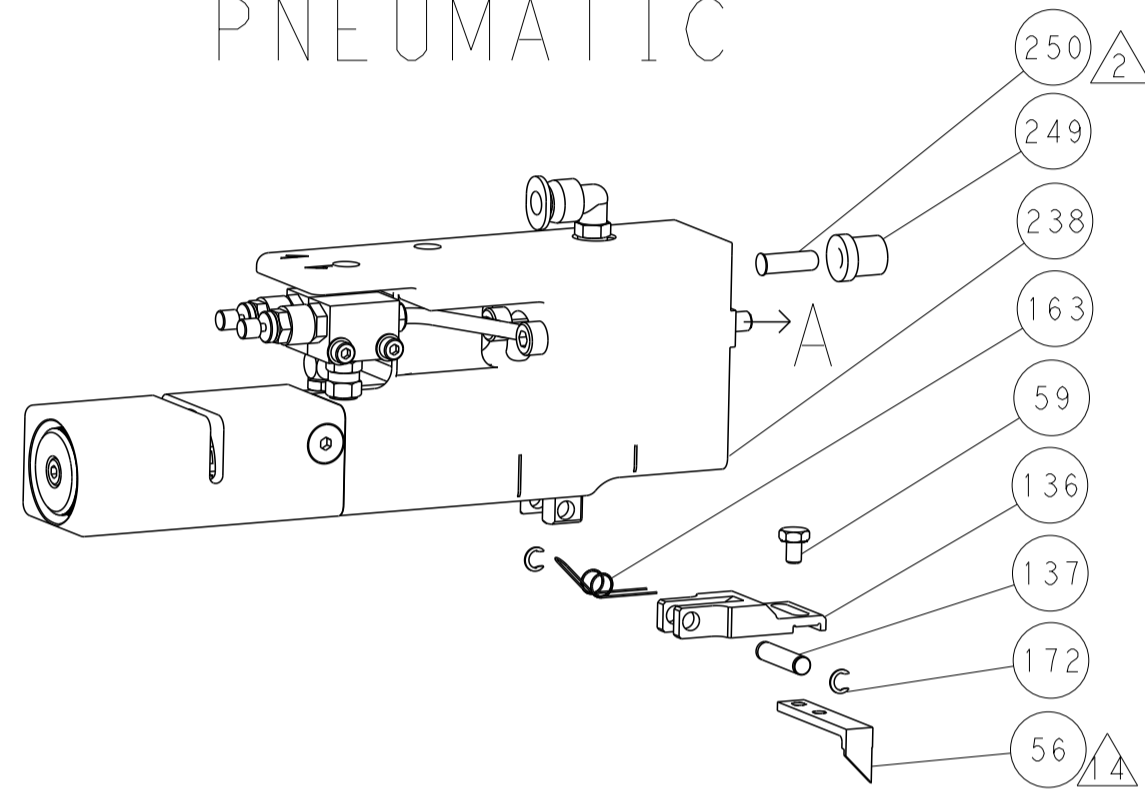

SERVO LATCH PLATE

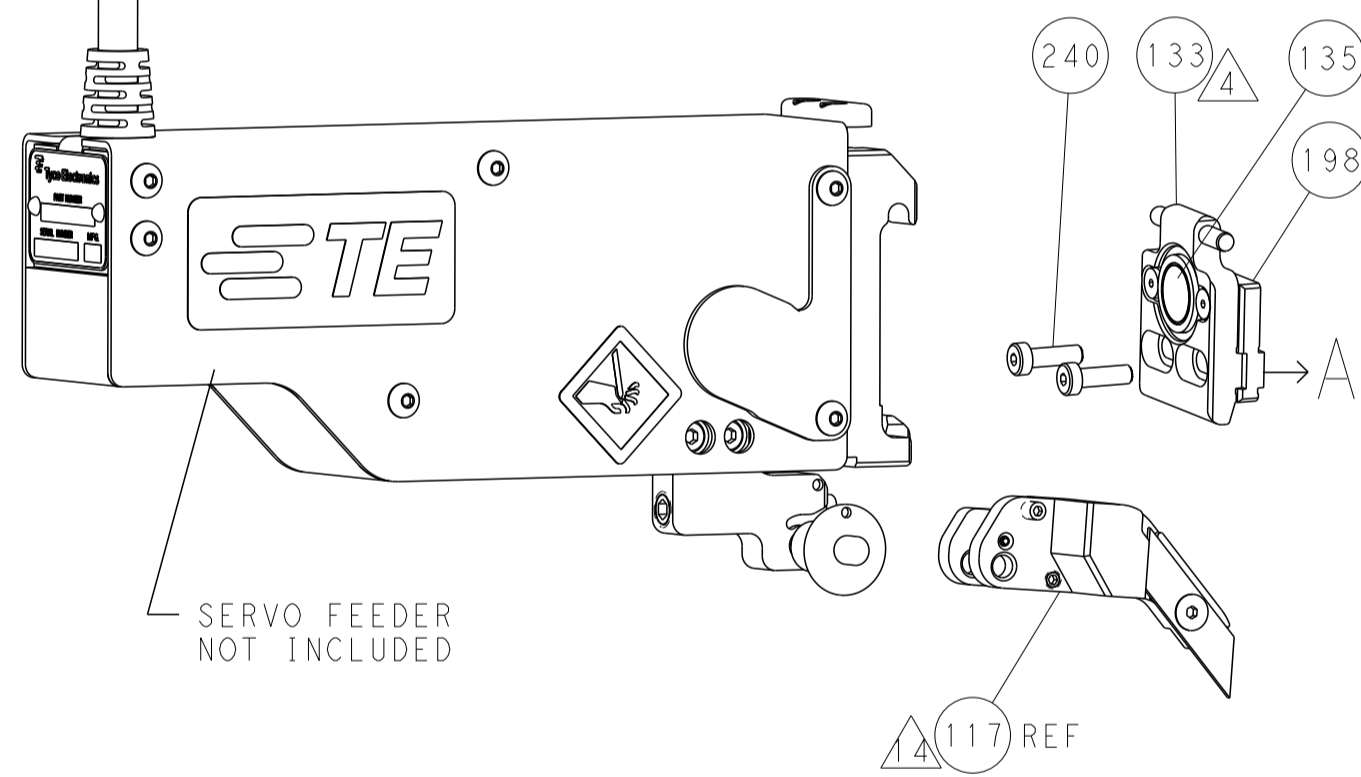

CAM POSITIONS

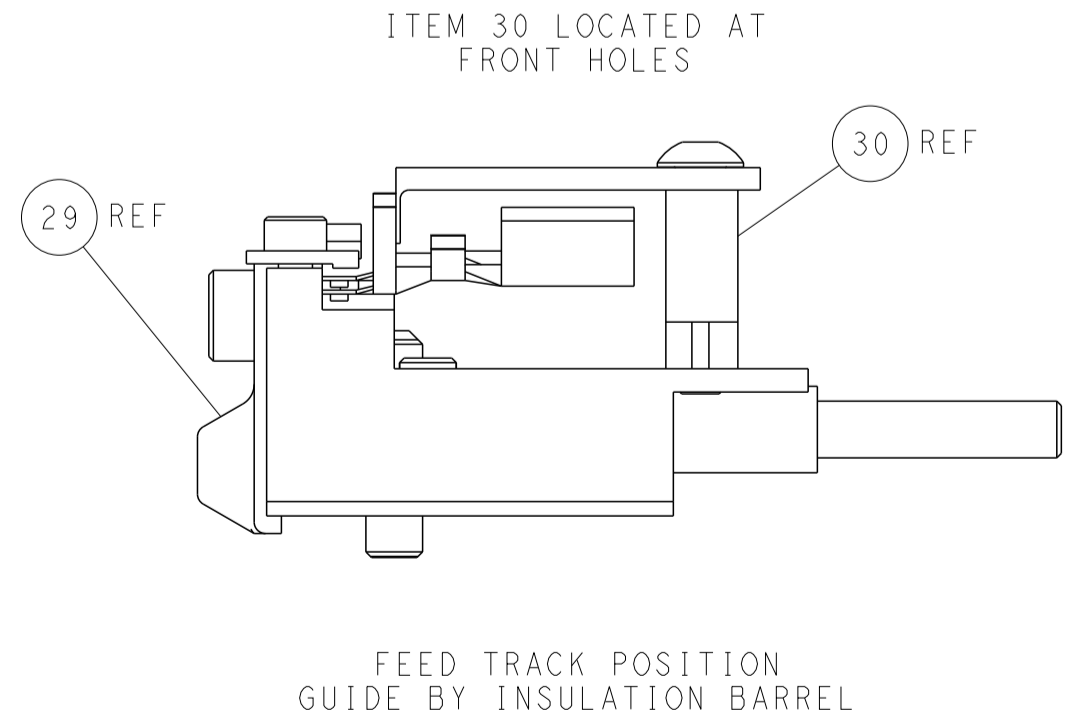
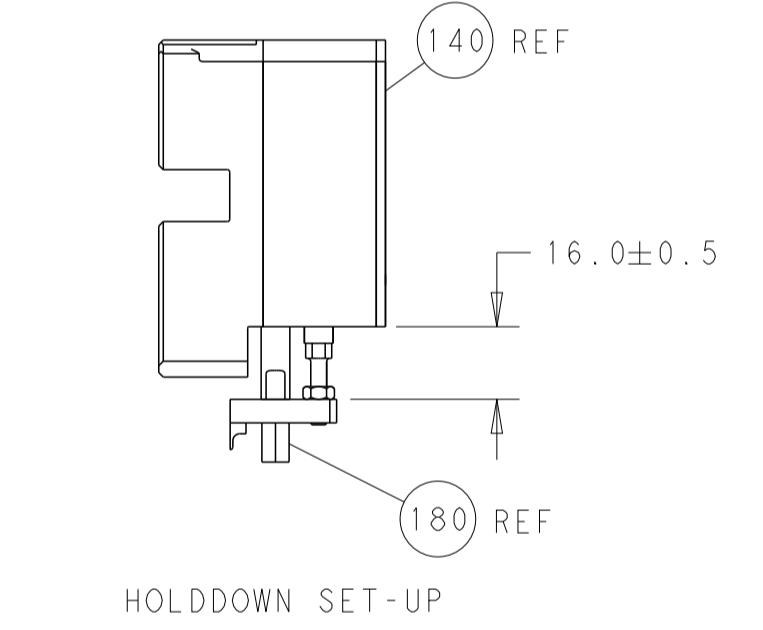
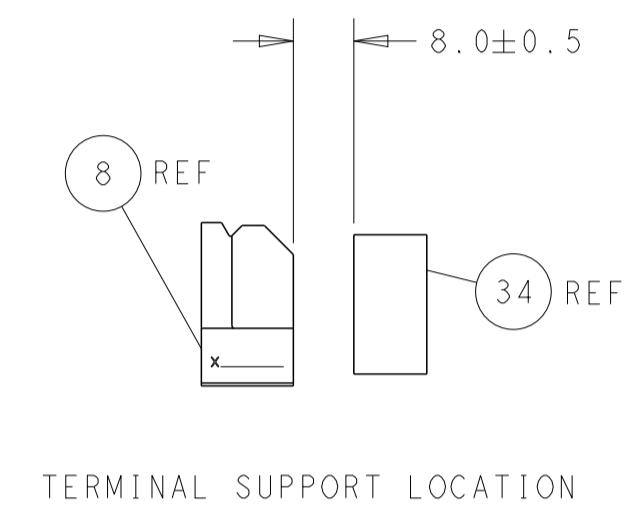
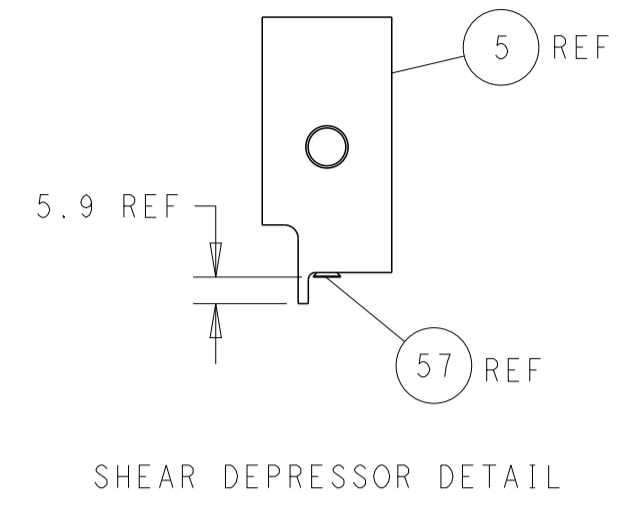
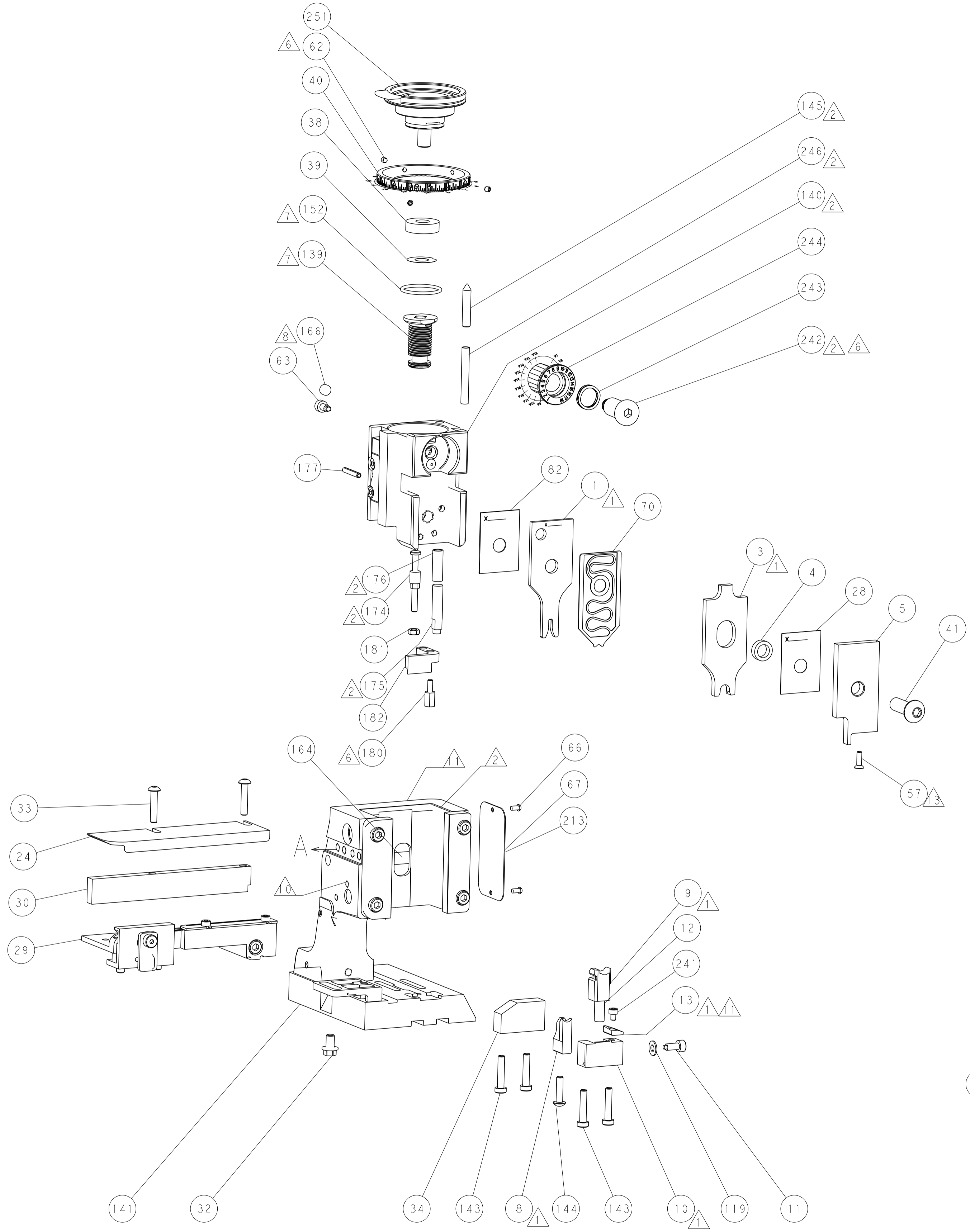
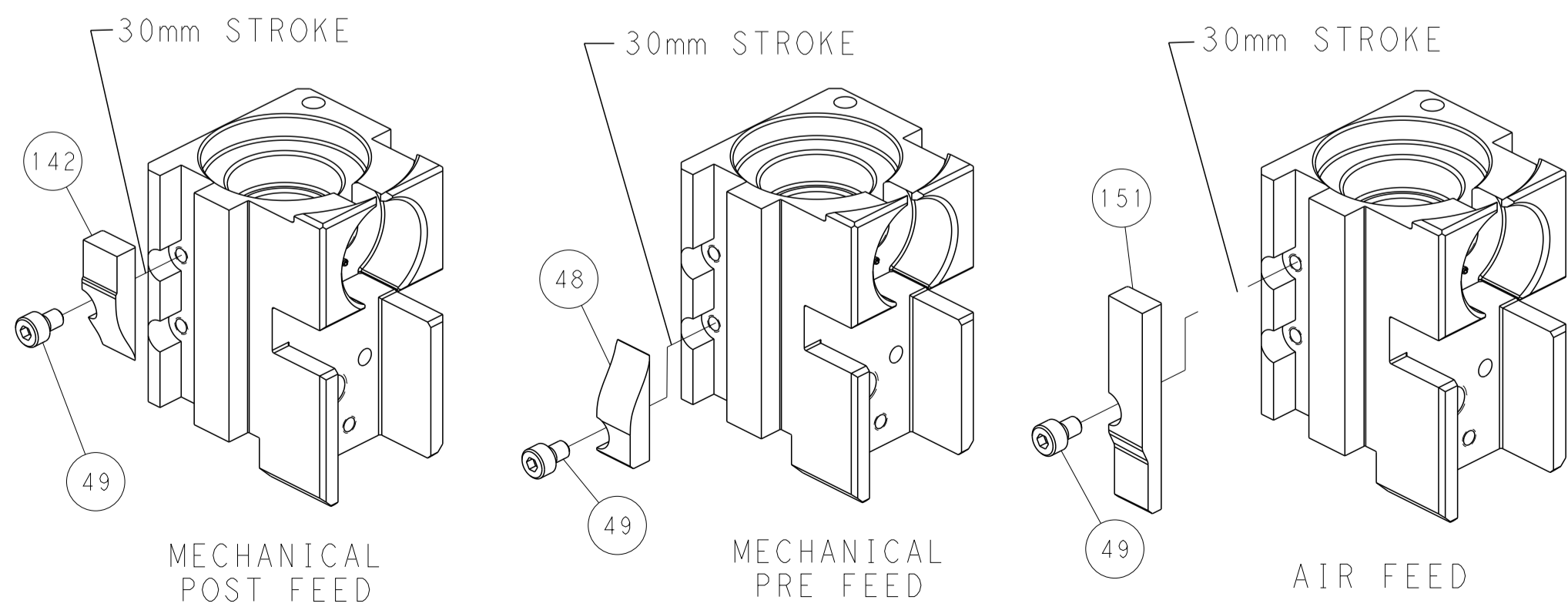

PACIFIC VERSION
 Shown on sheets 3 of 4 & 4 of 4
 (Atlantic version shown on sheets 1 of 4 & 2 of 4)

DIMENSIONS:		TOLERANCES UNLESS OTHERWISE SPECIFIED:		DWG: H. HUANG 24SEP2013		CHK: L. ZHANG 24SEP2013		APVD: H. GUO 24SEP2013		NAME: Ocean Side Feed Applicator	
mm	0 PLC	±		SIZE	CAGE CODE	DRAWING NO	RESTRICTED TO	STE TE Connectivity Harrisburg, PA 17105-3608			
	1 PLC	±		SCALE	00779	©=2266056		Customer Accessible Production Drawing			
	2 PLC	±		SHEET	4	4	REV	B1			
	3 PLC	±		Customer Accessible Production Drawing							
	4 PLC	±		SCALE 1:2 SHEET 4 OF 4 REV B1							
	ANGLES	±		SHEETS 1 & 2 ARE NOT REQUIRED FOR PACIFIC VERSION							
	FINISH	±									