

Tous droits strictement réservés. Reproduction ou communication à des tiers interdite sous quelque forme que ce soit sans autorisation écrite du propriétaire de c. FCI. Droits de reproduction FCI.



All rights strictly reserved. Reproduction or issue to third parties in any form whatsoever is not permitted without written authority from the proprietor. Property of FCI. Copyright FCI.

PRODUCT NO.	CONDUCTOR TYP. OF POS	CONDUCTOR ASS'Y POS. NO.
94104-x66(LF)	6/6	1,2,3,4,5,6
94104-x64(LF)	6/4	2,3,4,5
94104-x62(LF)	6/2	3,4
94104-x62I(LF)	6/2	1,6
94104-x44(LF)	4/4	1,2,3,4
94104-x42(LF)	4/2	2,3

- NOTE:
- FOR VISUAL MECHANICAL AND FUNCTIONAL REQUIREMENTS SEE PRODUCT SPEC.110-042.
  - HOUSING MAT'L:GLASS REINFORCED 66 NYLON ZYTEL-50. UL-94V-0
  - GOLD WIRE MAT'L:PHOS. BRONZE 0.44 DIA. PLATING:SEE TABLE.
  - A. STANDARD PACKAGING METHOD(USE TRAY);SEE GES-14-351.  
B. NON-STANDARD PACKAGING METHOD (USE TUBE); SEE GES-14-358 THE PART NO. SHOULD BE SUFFIXED WITH '\*T'.
  - IF LF P/N THE HOUSING WILL WITHSTAND EXPOSURE TO 260°C PEAK TEMPERATURE FOR 10 SECONDS IN A WAVE SOLDER APPLICATION WITH A 1.60mm MINIMUM THICK CIRCUIT BOARD

CODE*X*	PLATING	HOUSING COLOR
0	6u" Au 20u" Min NICKEL UNDERPLATED	GRAY
1	2u" Au 20u" Min NICKEL UNDERPLATED	
2	6u" Au 20u" Min NICKEL UNDERPLATED	BLACK
3	2u" Au 20u" Min NICKEL UNDERPLATED	

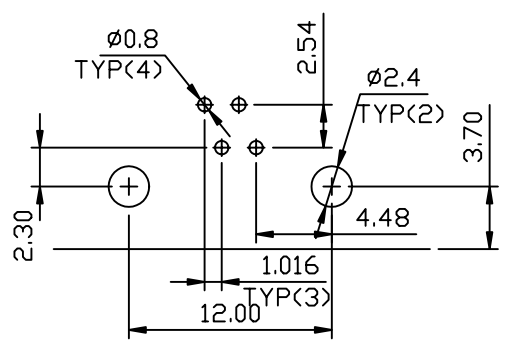
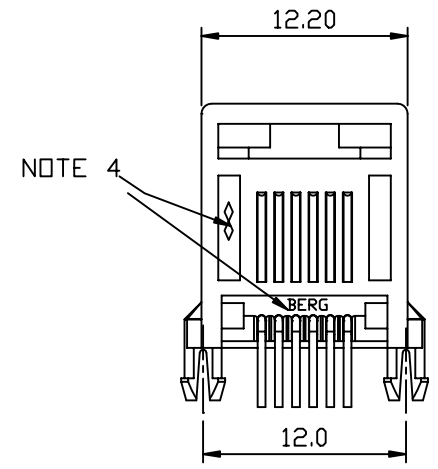
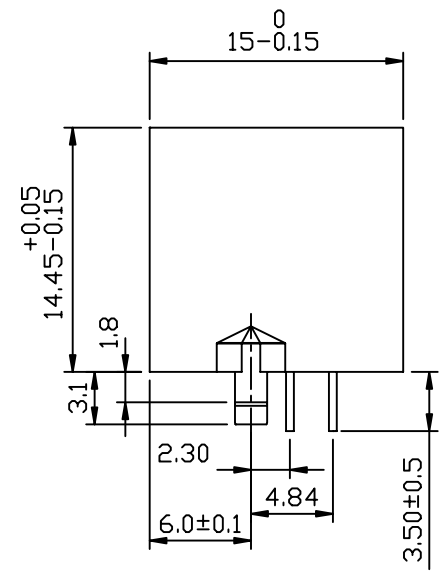
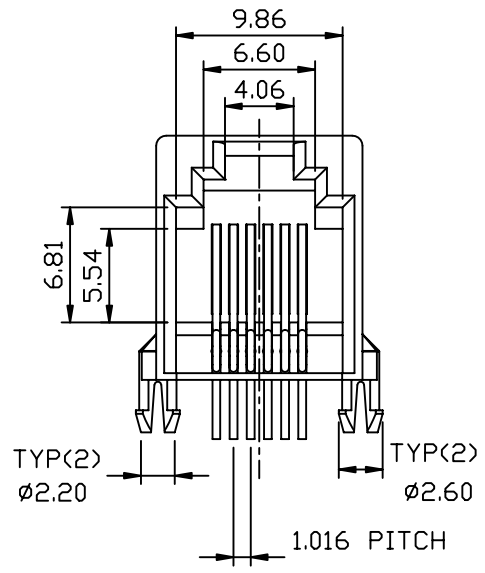
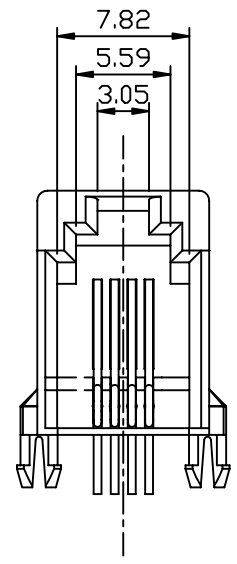

RECOMMENDED P.C.B.(.063 THK) PATTERN---4POS

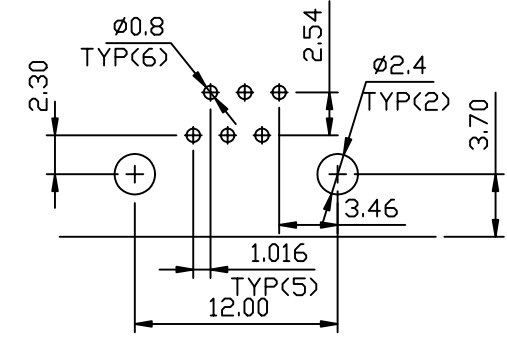

RECOMMENDED P.C.B.(.063 THK) PATTERN---6POS

mat'l. code				tolerances unless otherwise specified		CUSTOMER COPY		FCI		
ltr	ecn no	dr	date	linear	.XX ± 0.13	projection	www.fciconnect.com			
C	N05-0126	ZC	5/11/05		.XXX ± 0.05	MM/INCH	title			
D	N06-0160	LONG	6/14/06	angles	±		LOW PROFILE MOD JACKL PCB WITHOUT PANEL STOP GOLD FLASH			
E	N06-0232	LONG	9/01/06			scale	product family		code	
				dr	Zhengcai Tao		5/11/05	Module Jack	size	dwg no
				enr	Zhengcai Tao	5/11/05	1:1	A3	94104	sheet
				chr	Zhengcai Tao	5/11/05				1 of 1
				appd	Jason Zhou	5/11/05				
sheet index	revision sheet									