

6

5

4

3

2

1

APPROVED: _____

DATE: _____ TITLE: _____

Rev	AWO #	Description	Date	Appr
-	7723	RELEASED	5/31/05	
A	7723	UPDATED DRAWING	3/8/16	HR

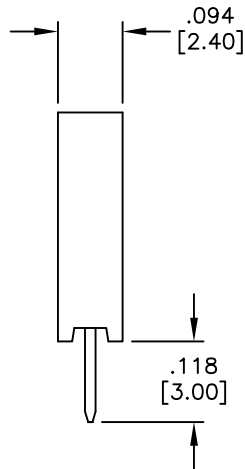
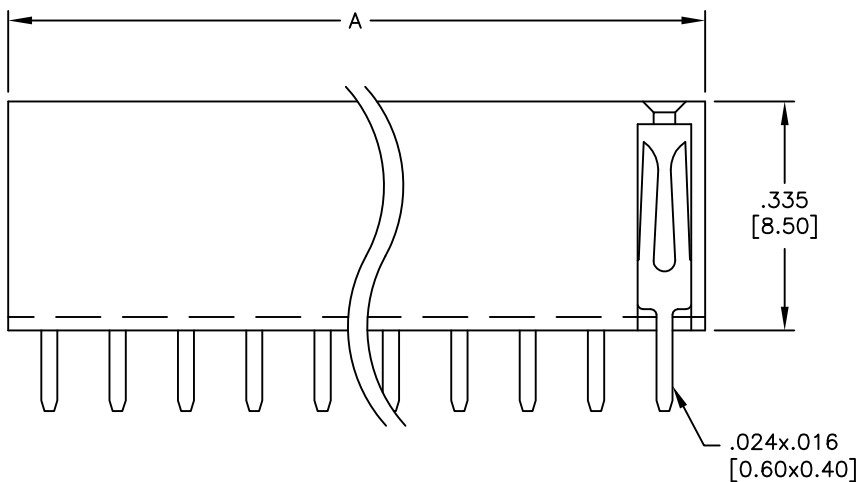
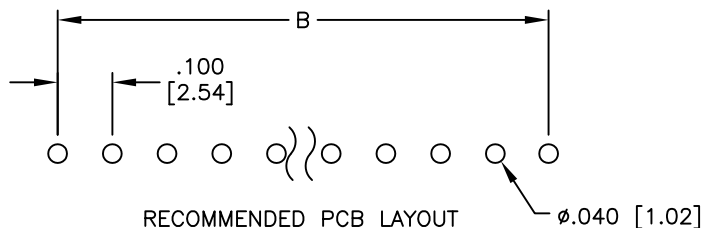
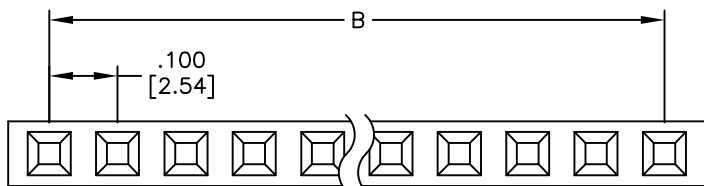

SPECIFICATIONS:

Material:
 Insulator: PBT, glass reinforced, rated UL 94V-0
 Insulator color: Black
 Contacts: Brass
 Plating:
 Gold flash over Nickel underplate overall
 Electrical:
 Current rating: 3 Amps max.
 Contact resistance: 20 mohms max. initial
 Insulation resistance: 5,000 Mohms min.
 Temperature Rating:
 Operating temperature: -40°C to +105°C
 Environmental:
 Lead free, RoHS compliant



Positions: 02 thru 40

A = .100 [2.54] x No. of Positions + .020 [0.50]

B = .100 [2.54] x No. of Spaces

UNLESS OTHERWISE SPECIFIED
 ALL DIMENSIONS ARE INCHES [MM]
 TOLERANCES: EXCEPT AS NOTED

INCHES		HOLES	
.X	± .10	Ø.X	± .10
.XX	± .020	Ø.XX	± .015
.XXX	± .015	Ø.XXX	± .010

ADAM TECH

909 Rahway Avenue, Union, NJ 07083
 Phone: 908-687-5000 Fax: 908-687-5710

TITLE
 .100 [2.54] SINGLE ROW RECEPTACLE STRIP
 .335 [8.50] HEIGHT

APPROVALS		DATE
DRAWN	SS	5/31/05
CHECKED		
APPROVED		

SIZE	PART NO.	REV.
X	RS1-XX-G	A
REF: S00059T	SCALE: NTS	SHEET 1 OF 1

6

5

4

3

2

1