

LOC		DIST		REVISIONS			
P	LTR	DESCRIPTION	DATE	DMN	APVD		
M		REV PER ECO 15-006633	5-11-15	CT	DM		

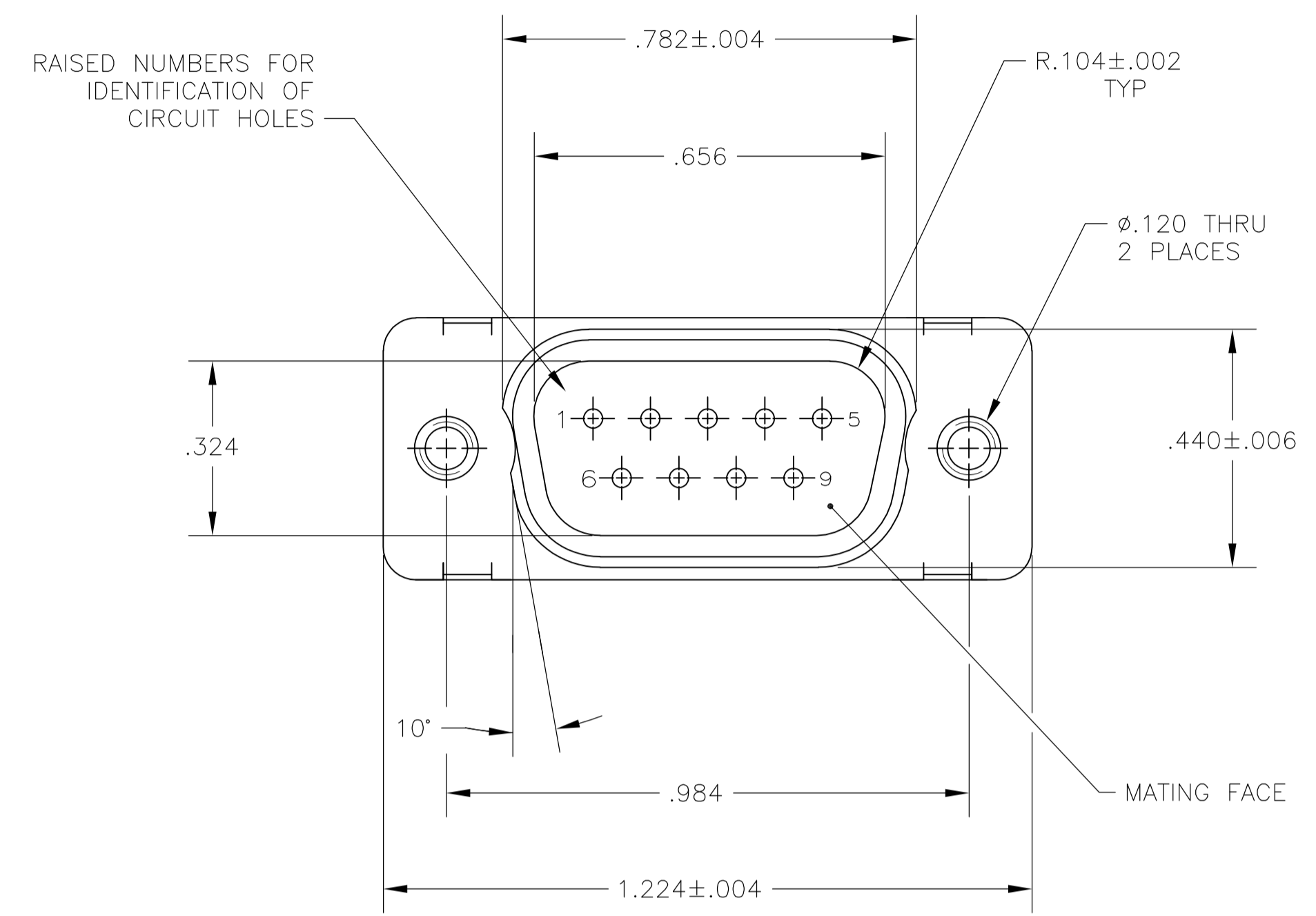

1. THIS PLUG WILL MATE WITH ANY 9 POSN, SIZE 1 RECEPTACLE IN AMPLIMITE SERIES.
2. MAXIMUM WIRE INSULATION TO BE USED WITH THIS PLUG IS .068 DIA.
3. SST RETENTION CLIPS ARE INCLUDED IN INSERTS.
4. THIS PLUG IS DESIGNED TO CONFORM TO THE LATEST ISSUE OF MIL-C-24308.
5. CONNECTOR SUPPLIED WITHOUT CONTACTS, SHOWN FOR ILLUSTRATION ONLY.
6. THIS PLUG WILL ACCEPT SIZE 20 DM PIN CONTACT M39029/64-369 OR ANY AMP SIZE 20 OF PIN CONTACT.
7. FINISH: CADMIUM PER QQ-P-416; YELLOW CHROMATE.
8. FINISH: ZINC PLATED PER ASTM-B-633 .000200 MIN THK WITH SUPPLEMENTARY CHROMATE (Cr3+).

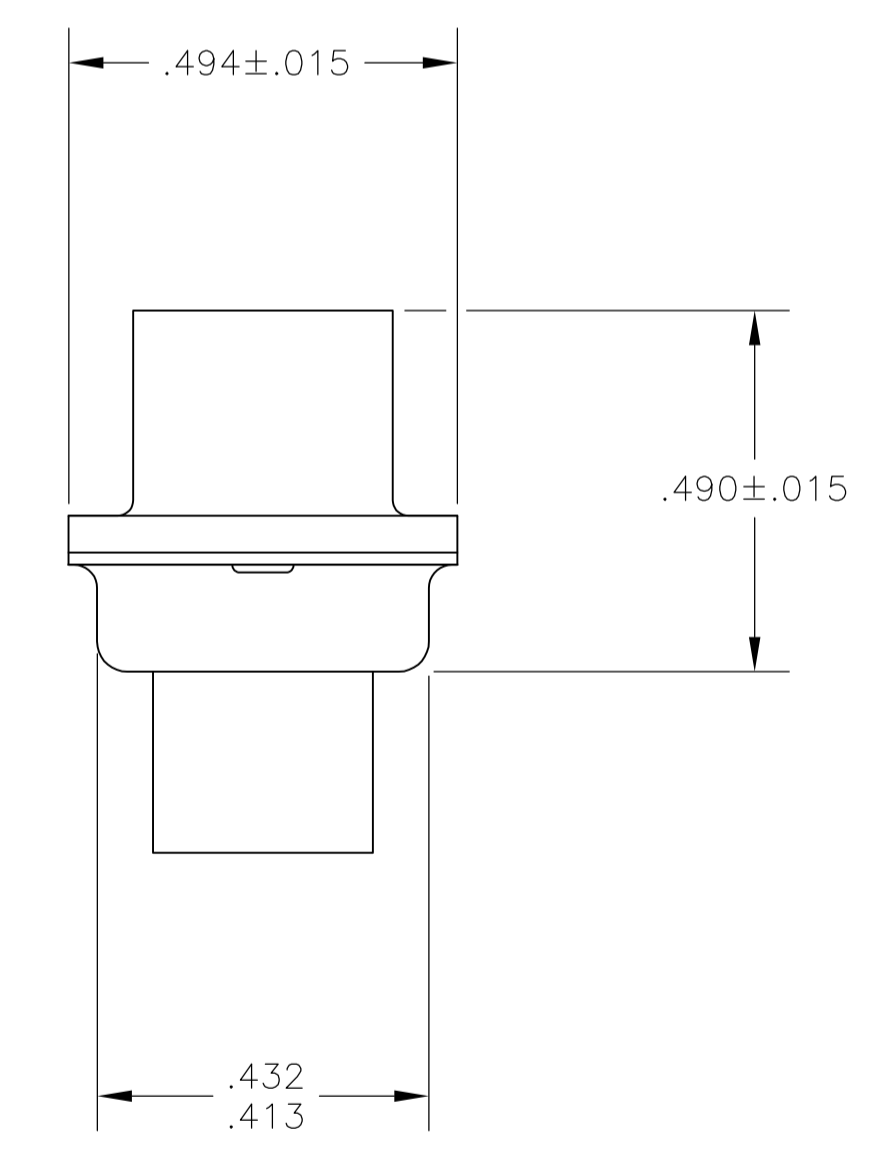
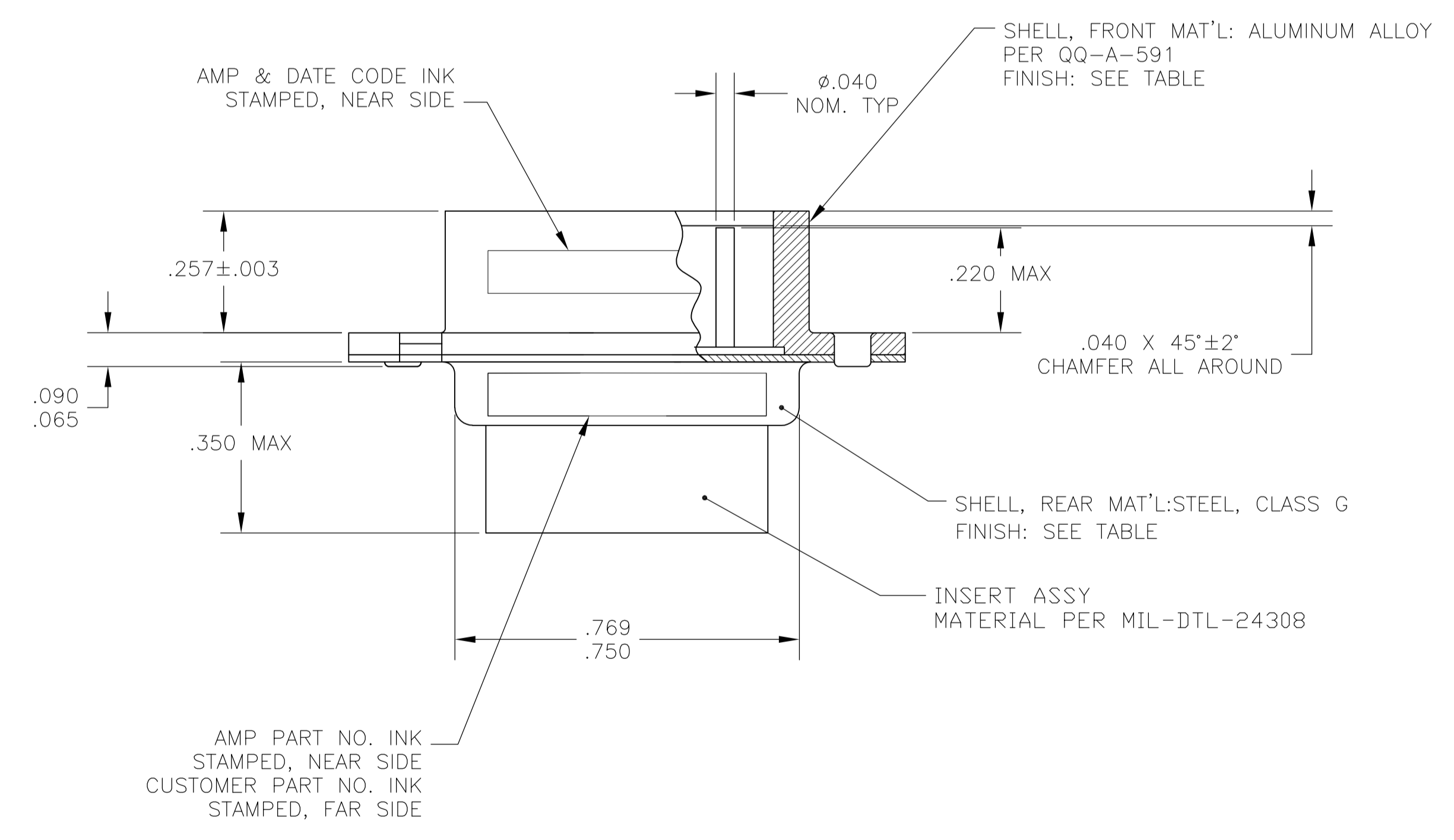

8	5-445005-1
7	445005-1
FINISH	PART NO.

THIS DRAWING IS A CONTROLLED DOCUMENT.

DIMENSIONS: INCHES	TOLERANCES UNLESS OTHERWISE SPECIFIED:	DIN B LATTUCA 4 JAN 2006	APVD F BALLEW 1-22-88	NAME	PLUG ASSY., AMPLIMITE, 9 POSN., SIZE 1, SERIES 109 BLINDMATE
0 PLC ± -	1 PLC ± -	2 PLC ± -	3 PLC ± .005	4 PLC ± -	ANGLES ± 0°30'
MATERIAL SEE CALLOUT	FINISH SEE CALLOUT	WEIGHT -	SIZE A1	CAGE CODE 00779	DRAWING NO. 445005
CUSTOMER DRAWING		SCALE -	SHEET 1 OF 1	REV M	RESTRICTED TO

STE TE Connectivity